

# Foreword

Thank you for choosing BYD. To better use and maintain the vehicle, please read this manual carefully before use and keep it for future reference.

Special instructions: BYD Auto Industry Co., Ltd. recommends that you choose genuine spare parts and use, maintain, and repair the vehicle in accordance with this manual. The use of non-genuine spare parts to replace or modify the vehicle will affect the performance of the entire vehicle, especially its safety and durability. Vehicle damage and performance issues caused thereby will not be covered by the warranty. In addition, vehicle modifications may also violate national laws and regulations and local government regulations.

Thank you for choosing BYD. Your valuable comments and suggestions are welcome. To enjoy better services, please provide your accurate contact information. If there is any change to the information, contact a BYD authorized dealer or service provider in a timely manner to update the information in the system. You are also advised to pay attention to the relevant national laws and regulations and local policies, and register the vehicle as soon as possible; otherwise vehicle registration may fail.

The descriptions marked with the asterisk (\*) in this manual are specific to only some model configurations, and applicable only when the vehicle has these configurations. If there is any difference with the vehicle you purchased, the configuration of the actual vehicle shall prevail.

Pay attention to the "REMINDER", "CAUTION" and "WARNING" symbols in this manual, and follow the instructions carefully to avoid injury or damage. These symbols are defined as follows:

## **REMINDER**

Items that must be observed to facilitate maintenance.

## **CAUTION**

Items that must be observed to avoid damage to the vehicle.

## **WARNING**

Items that must be observed to ensure personal safety.



is a safety mark to indicate an operation that should not be performed or an event that should not happen.

This manual is expected to help you use the product correctly, and does not provide any description of the configuration and software version of this product. For details about the product configuration and software version, please refer to the contract (if any) related to this product, or consult the dealer who sold the product to you.

Everyone has the responsibility to protect the environment. Please use this vehicle properly and dispose of any waste and cleaning materials according to the corresponding local laws and regulations.

**Copyright © BYD Auto Industry Co., Ltd. All rights reserved.**

**No part of this document may be reproduced, copied, stored, translated, or transmitted electronically or in any other form without prior written consent and authorization of BYD Auto Industry Co., Ltd.**

**All rights reserved**



## Figure Index

<b>Exterior</b> .....	<b>7</b>
<b>Dashboard</b> .....	<b>8</b>
<b>Interior</b> .....	<b>9</b>
<b>Doors</b> .....	<b>10</b>

## Safety

<b>Seat Belts</b> .....	<b>12</b>
Seat Belt Overview.....	12
Using Seat Belts.....	12
<b>Airbags</b> .....	<b>15</b>
Airbag Overview.....	15
Airbag Types.....	16
Airbag Triggering Conditions and Precautions.....	18
<b>Child Restraint System</b> .....	<b>21</b>
Child Restraint System.....	21
<b>Working Modes of Dual-Mode</b> .....	<b>25</b>
Introduction of Dual-Mode System Working Mode.....	25
Working Mode Selection of Dual-Mode System.....	26
Working Mode Precautions of Dual-Mode System.....	28
<b>Anti-theft Alarm System</b> .....	<b>30</b>
Anti-theft Alarm System.....	30
<b>Data Collection and Processing</b> .....	<b>30</b>
Data Collection and Processing.....	30

## Instrument Cluster

<b>Instrument Cluster</b> .....	<b>36</b>
Instrument Cluster View.....	36
Instrument Cluster Indicators.....	37

## Controller Operation

<b>Doors and Keys</b> .....	<b>50</b>
Keys.....	50
Locking/Unlocking Doors.....	53
Smart Access and Start System.....	59
Child Protection Lock.....	60
<b>Seats</b> .....	<b>61</b>
Seat Precautions.....	61
Adjusting Front Seats.....	62
Folding Rear Seats.....	63
Head Supports.....	64
<b>Steering Wheel</b> .....	<b>65</b>
Steering Wheel Switches.....	65
Adjusting the Steering Wheel.....	67
<b>Wipers</b> .....	<b>68</b>
Wiper Switch.....	68
Replacing Wiper Blades.....	69
<b>Rearview Mirrors</b> .....	<b>70</b>
Interior Rearview Mirror.....	70
Side Mirrors.....	71
<b>Switches</b> .....	<b>72</b>
Light Switches.....	72
Driver's Door Switches.....	75
Window Control Switch on Passenger Side.....	76
Odometer Switch.....	77
Hazard Warning Light Switch.....	77
Interior Light Switch.....	77
Pickup Bed Light Switch.....	78

## Using and Driving

<b>Charging/Discharging</b> .....	<b>80</b>
Charging Instructions.....	80
Charging.....	83

Discharging Equipment.....	90
Target SOC Setting.....	94
Charging Port Immobilizer System.....	95
Driving Range Display*.....	97
Regenerative Braking Intensity Settings.....	98
<b>Batteries.....</b>	<b>98</b>
High-Voltage Battery.....	98
Low-Voltage Battery.....	100
<b>Usage Precautions.....</b>	<b>101</b>
Break-in Period.....	101
Trailer Towing.....	102
Driving Safety Precautions.....	109
Suggestions for Vehicle Use.....	110
Fuel.....	111
Saving Fuel and Extending Vehicle Service Life.....	112
Carrying Luggage.....	114
Risk of Carbon Monoxide (CO) Poisoning.....	115
Wading into Water.....	116
Fire Prevention.....	117
Snow Chains.....	119
<b>Starting and Driving.....</b>	<b>120</b>
Starting the Vehicle.....	120
Driving.....	121
Driving Mode.....	123
Driving with Low Fuel Consumption....	125
Gear Shift Controls.....	126
Electronic Parking Brake (EPB).....	128
Automatic Vehicle Hold (AVH).....	131
Driving Precautions.....	132
<b>Driver Assistance.....</b>	<b>134</b>
Adaptive Cruise Control (ACC)*.....	134
Intelligent Cruise Control (ICC)*.....	138
Traffic Sign Recognition (TSR)*.....	140

Intelligent Speed Limit Control (ISLC)*.....	141
Forward Collision Warning (FCW) & Automatic Emergency Braking (AEB)*..	142
Front Cross Traffic Alert (FCTA) and Front Cross Traffic Brake (FCTB).....	145
Intelligent High Beam Control (IHBC)*.	146
Lane Departure Assist (LDA)*.....	147
Emergency Lane Keeping Assist (ELKA)*.....	149
Blind Spot Assist (BSA)*.....	150
Head-up Display (W-HUD)*.....	152
Driver Monitoring Systems (DMS).....	153
Child Presence Detection (CPD).....	154
Direct Tire Pressure Monitoring System.....	156
Acoustic Vehicle Alert System (AVAS)...	157
Panoramic View*.....	158
Parking Assistance.....	160
Driving Safety System.....	163

## In-Vehicle Devices

<b>Infotainment System.....</b>	<b>170</b>
Infotainment Touchscreen.....	170
Navigation Bar.....	171
Gestures and Responses.....	171
OTA Upgrade.....	171
BYD Assistant.....	172
Bluetooth.....	172
My Car*.....	173
File Management.....	173
<b>A/C System.....</b>	<b>173</b>
A/C Panel.....	173
A/C Operation Interface.....	174
Function Definition.....	175

Switching on A/C with Cloud Service App.....	178
Vents.....	178
<b>BYD App.....</b>	<b>179</b>
About BYD App.....	179
Account Registration.....	179
Vehicle Condition and Control.....	179
Individual Center and Vehicle Management.....	180
<b>Storage.....</b>	<b>180</b>
Door Bins.....	180
Glove Box.....	180
Center Console Cubby.....	180
Seatback Pockets.....	180
Glasses Case.....	181
Cup Holder.....	181
<b>Other Devices.....</b>	<b>181</b>
Sun Visor.....	181
Grab Handles.....	182
USB Ports.....	182
On-Board Power Supply.....	183
Wireless Phone Charger.....	183

## Maintenance

<b>Maintenance Precautions.....</b>	<b>188</b>
Maintenance Cycle and Items.....	188
<b>Regular Maintenance.....</b>	<b>194</b>
Regular Maintenance.....	194
Vehicle Corrosion Prevention.....	195
Paint Maintenance Tips.....	196
Exterior Cleaning.....	196
Interior Cleaning.....	197
<b>Self-Maintenance.....</b>	<b>199</b>
Self-Maintenance.....	199
Vehicle Storage.....	201

Hood.....	202
Engine.....	203
Cooling System.....	204
Braking System.....	205
Washer.....	205
Fuel Filter.....	206
A/C System.....	206
Wiper Blades Maintenance.....	206
Tires.....	207
Fuses.....	210

## When Faults Occur

<b>When Faults Occur.....</b>	<b>212</b>
Reflective Vest.....	212
If Smart Key Battery Is Exhausted.....	212
If a High Voltage Fault Occurs.....	212
If the Vehicle Cannot be Powered on... ..	212
If the Engine Fails to Start While Driving.....	213
If the Engine Is Overheated.....	214
If the Vehicle Needs Towing.....	214
If a Tire Goes Flat.....	216
Using the Spare Tire.....	217

## Specifications

<b>Vehicle Data.....</b>	<b>224</b>
Vehicle Specifications.....	224
<b>Information.....</b>	<b>228</b>
Vehicle Identification.....	228
Warning Labels.....	229
Transponder Mounting.....	230
<b>Declarations of Conformity.....</b>	<b>231</b>
Declarations of Conformity.....	231

## Abbreviations

Abbreviations.....239

# Figure Index

## Exterior

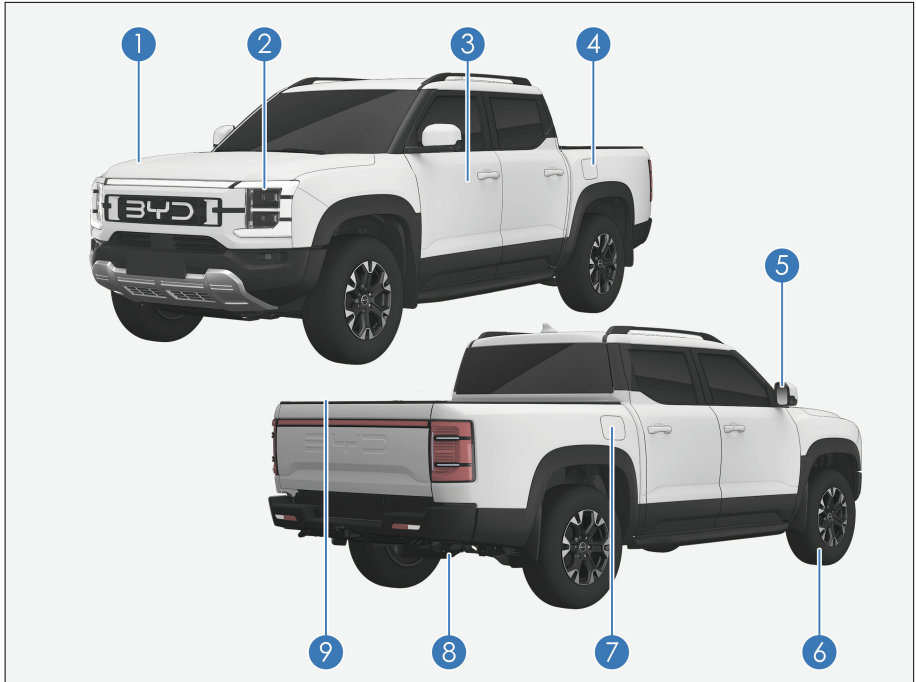

- |   |                                    |   |   |
|---|------------------------------------|---|---|
| 1 | Hood <b>P202</b>                   | 6 | Tires <b>P207</b>                         |
|   | Engine Oil <b>P203</b>             |   | If a Tire Goes Flat <b>P216</b>           |
|   | Cooling System <b>P204</b>         | 7 | Check Before Charging <b>P83</b>          |
|   | Braking System <b>P205</b>         |   | Using Mode 2 Charging Cable <b>P83</b>    |
|   | Windshield washer <b>P205</b>      |   | Using AC Charging Piles <b>P87</b>        |
| 2 | Light Switches <b>P72</b>          |   | Using DC Charging Piles* <b>P88</b>       |
| 3 | Unlocking/Locking Doors <b>P54</b> | 8 | Replacement of the Spare Tire <b>P218</b> |
| 4 | Refueling <b>P111</b>              | 9 | Tailgate <b>P56</b>                       |
| 5 | Power Side Mirrors <b>P71</b>      |   |   |

# Dashboard

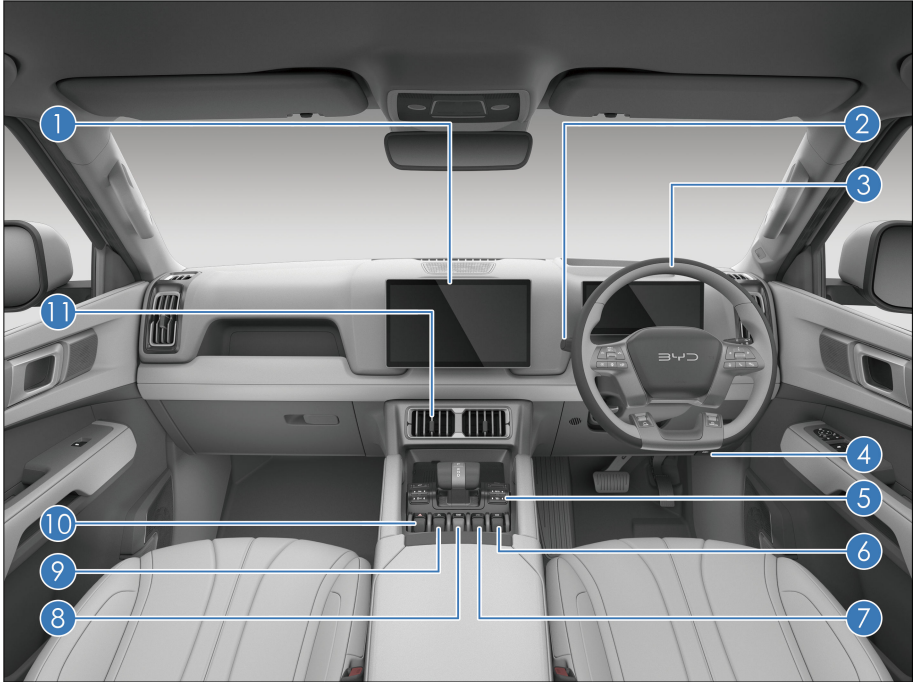

- |   |   |    |                                      |
|---|---|----|--------------------------------------|
| 1 | Infotainment Touchscreen <b>P170</b>          | 6  | AVH Switch <b>P131</b>               |
| 2 | Front Windshield Wipers and Washer <b>P68</b> | 7  | Opening the Tailgate <b>P56</b>      |
| 3 | Steering Wheel Switches <b>P65</b>            | 8  | START/STOP Button <b>P120</b>        |
| 4 | Hood Handle <b>P202</b>                       | 9  | EV/HEV Mode Switch Button <b>P26</b> |
| 5 | Front A/C Panel <b>P173</b>                   | 10 | Hazard Warning Light <b>P77</b>      |
|   |   | 11 | Front Center Vent <b>P178</b>        |

# Interior

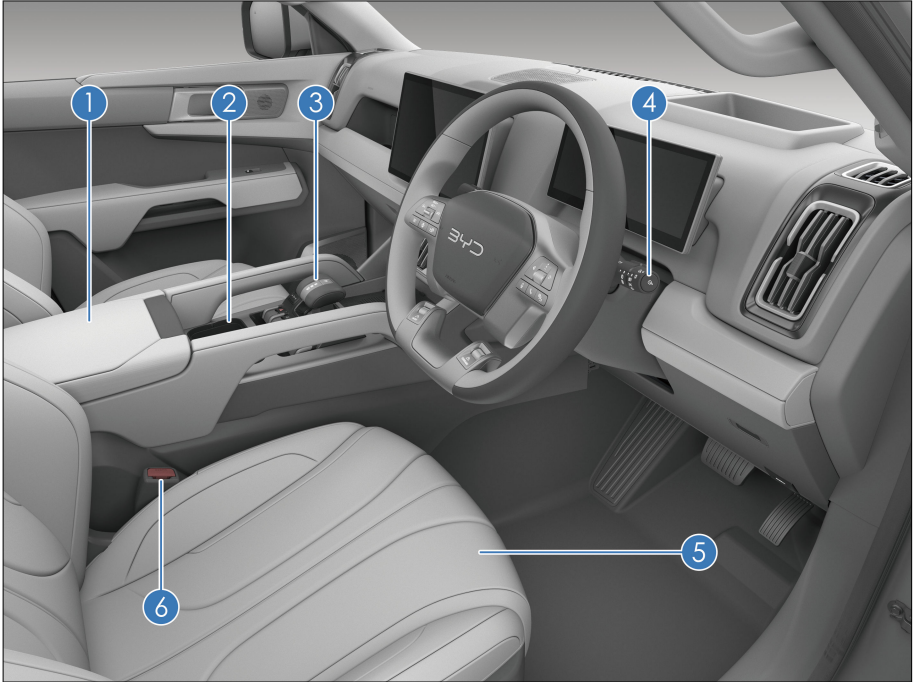

- 1 Center Console Cubby **P180**
- 2 Cup Holder **P181**
- 3 Gear Shift Controls **P126**

- 4 Light Switches **P72**
- 5 Seats **P61**
- 6 Using Seat Belts **P12**

# Doors

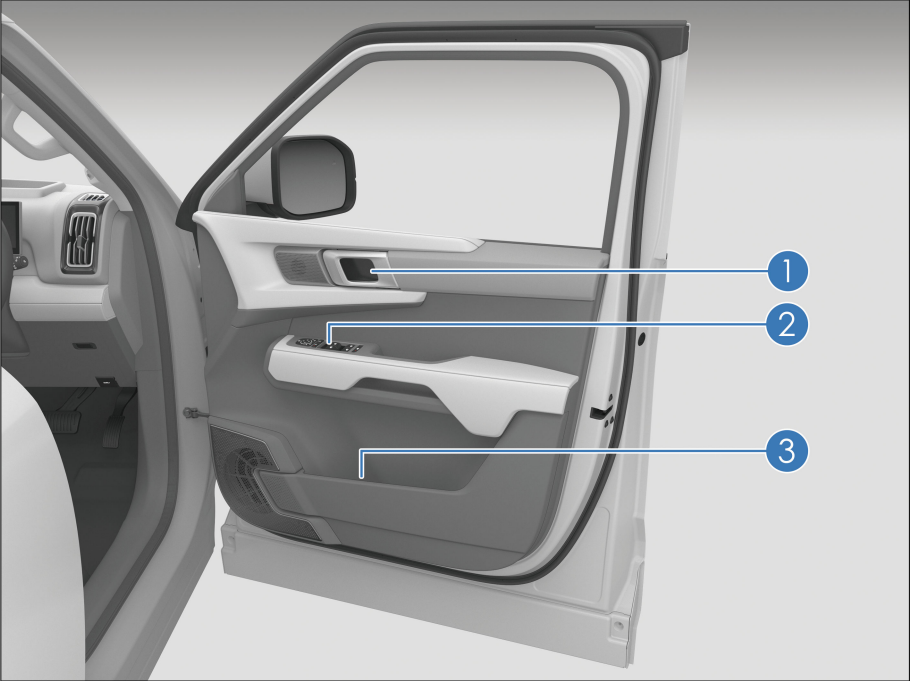

1 Interior Door Handle **P53**

Side Mirror Adjustment **P71**

2 Power Window Switches **P75**

3 Door Bins **P180**

Central Locking **P76**



# 01

## SAFETY

Seat Belts.....	12
Airbags.....	15
Child Restraint System.....	21
Working Modes of Dual-Mode.....	25
Anti-theft Alarm System.....	30
Data Collection and Processing.....	30

# Seat Belts

## Seat Belt Overview

Studies have shown that proper use of seat belts can significantly reduce casualties in emergency braking, sudden steering or collisions. Please read the following information carefully and observe it strictly.

### WARNING

- Before driving, make sure all occupants are properly buckled up to prevent serious injury or death in emergency braking or in a collision.
  - The seat belts are designed primarily for adults and are not intended for children. Make sure to choose an appropriate child restraint system according to your child's age and size (see **P21** in this chapter).
  - If a seat belt is damaged or malfunctions, immediately contact a BYD authorized dealer or service provider for confirmation and handling. Until then, do not use the corresponding seat.
- All occupants should always fasten their seat belts while in the vehicle to avoid personal injury or death in case of accident.
  - The installed seat belts are designed for adults. Children should be seated in rear seats and always use seat belts and suitable child restraints. In case of emergency braking or a collision, unprotected children may be seriously injured and their lives may be endangered.

- Children must never ride on an occupant's lap. This will render the children not adequately protected in case of emergency braking or a collision.

### Emergency Locking Retractor (ELR) Function

- This vehicle is equipped with emergency locking seat belts. During the sharp turn, emergency braking and collision process, or when the occupant leans forward too quickly, the seat belt retractor will lock into position to protect the occupant.
- When the vehicle travels smoothly, seat belts are pulled out and retracted as the occupants move slowly and smoothly, allowing the occupants to move freely.
- If the seat belt locks due to sudden retraction of emergency locking, pull on the seat belt webbing to create retractable slack in order to pull out the seat belt.

### Seat Belt Pretensioner and Force Limiter Function\*

When a severe front collision occurs and the triggering conditions of the pretensioner are met, the pretensioner quickly retracts part of the seat belt and locks it to improve the protection of the occupant. The force limiter limits the seat-belt restraint force to the occupant's body to a certain extent so as to avoid injury to the occupant due to an excessive restraint force.

## Using Seat Belts

1. Adjust the seat position and seatback angle (see "Adjusting Front Seat with Power").

2. Adjust the position of the three-point seat belt.
  - Keeping a proper sitting posture, pull the seat belt out so that it is diagonally across the chest. The belt should not go under the arm or across the back of the neck.
  - Keep the lap section of the belt as close as possible to the hip and do not keep it on the waist.

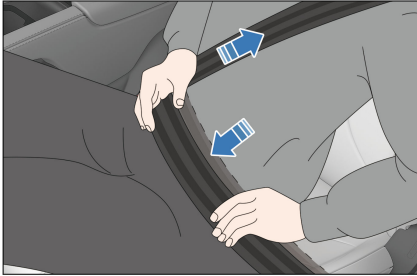

3. Insert the latch into the buckle until it clicks, and then pull it back to make sure it is firmly locked. Do not fasten the belt with any part of the strap twisted.

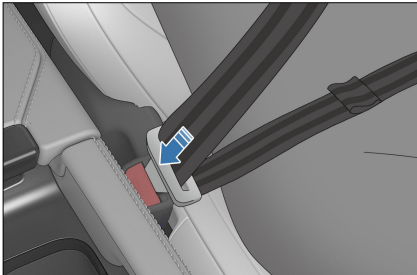

4. Adjust the height of the (front) seat belts for optimum comfort and protection.
  - ① Press the adjuster release button.
  - ② Move the adjuster up or down to the intended position and release it.

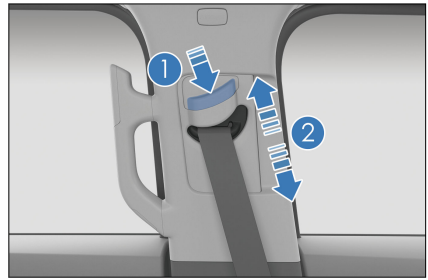

5. Pull the shoulder belt firmly to check that the adjuster is locked.

**WARNING**

- The shoulder belt should cross the center of the shoulder. The seat belt should be far from the neck and not liable to slip from the shoulder; otherwise, it cannot function well in the event of emergency braking or accident and may even cause severe injury.
- The lap belt should be positioned as low as possible around the hips to avoid serious injury due to the intense lap belt forces against the abdomen in an accident.
- The seat belt should be fitted tight to the body for better protection.

6. Unlock the seat belt.
  - Press the red unlock button on the buckle. The latch plate pops out, and the seat belt automatically retracts.
  - If the seat belt does not retract smoothly and automatically, pull it out and check whether it is twisted.

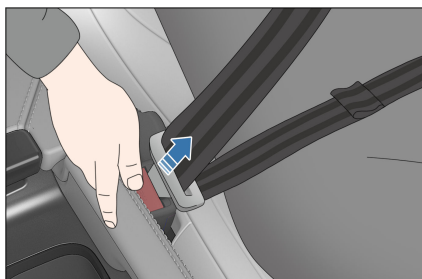

### WARNING

- One seat belt is for one occupant only. Do not allow multiple occupants (including children) to share one seat belt.
- Avoid traveling with the seatback leaning too far back. The seat belt protection performs best when the seatback is upright.
- Make sure that no seat belt or its spring bolt/buckle becomes pressed by the door; otherwise, the seat belt may be damaged.
- Check the seat belts regularly for cuts, wear, looseness, and other abnormalities. If any problem is found, immediately contact a BYD authorized dealer or service provider for confirmation and handling. Until then, do not use the corresponding seat.
- Do not remove, disassemble or modify the seat belts without permission.
- After an accident, have the seat belts checked at a BYD authorized dealer or service provider. If the pretensioner function is activated, the seat belt must be replaced.
- Use an approved model whenever you replace the seat belt.
- In the event of a serious accident, even if there is no

### WARNING

apparent damage, the seat belt should be replaced along with the seat assembly. The airbag system should also be thoroughly inspected.

- Pregnant women should also fasten the seat belt properly as other occupants, and pay special attention to the lap belt which should be positioned as low as possible around the hips to avoid serious injury to them and their fetus due to the intense lap belt forces against the abdomen in an accident.
- The method of wearing a rear seat belt is the same as that for a front seat belt. For normal functioning of the rear seat belt, ensure that its latch is inserted into the corresponding buckle during use. The driver should ensure that all occupants are wearing seat belts before driving the vehicle.
- Do not insert foreign objects such as coins and clips into the buckle as they prevent proper connection between the latch and buckle.

### Seat Belt Reminders

If any occupant has not buckled up after the vehicle is started, visual and audible alarms go on and continue until the corresponding seat belt is properly fastened.

- Seat belt reminder indicator  
Any unfastened seat belt triggers this indicator to light up and flash as required.
- Display of unfastened belt's seat  
The indicator for the seat with unfastened seat belt lights up on the

instrument cluster and is steady on in case of abnormal conditions in the vehicle.

- Unfastened seat belt reminder

If any vehicle occupant has not buckled up after the ignition is switched on, the seat belt reminder indicator and the indicator associated with the corresponding seat light up. If the seat belt remains unfastened while driving, in addition to the reminder indicator, an audible alarm is given to alert the driver and the occupants.

- When the driver and all the passengers fasten their seat belts, the seat belt reminder indicator turns off and all indicators displayed for the corresponding seats turn off on the instrument cluster.

 **WARNING**

- In the event of abnormality or function failure, contact a BYD authorized dealer or service provider. Do not use the corresponding seat until the functions return to normal.
- When driving, make sure all occupants have their seat belts properly fastened to prevent serious injury or death in emergency braking or in a collision.

## Airbags

### Airbag Overview

- The airbag system is a part of supplemental restraint system (SRS) and also a supplement to seats and seat belts. When the vehicle is involved in a serious collision and the airbag system meets its deployment

conditions, relevant airbags will rapidly deploy and, along with seat belts, provide additional protection for heads and chests of the occupants to reduce the risk of personal injury or even death.

- Airbags are divided into front and side types according to the type of collision in which they are designed to deploy. The front airbags include a driver airbag and a front passenger airbag, while the side airbags include front seat side airbags and side curtain airbags.
- As an integral part of the vehicle's passive safety protection system, the airbag system does not replace seat belts, and must be used in combination with seat belts to maximize protection.

 **WARNING**

- Occupants must sit in a proper position to maximize the protection provided by seat belts and the airbag system.
- Do not disassemble or assemble airbag components.
- Non-BYD genuine seat covers may worsen the airbag performance or result in injury.
- Do not place anything between the side airbag and the occupant.
- Do not apply excessive force to the side of seats equipped with side airbags.
- After a crash, even if the airbag did not deploy and the pretensioner did not lock the seat belt, contact a BYD authorized dealer or service provider for inspection as soon as possible to ensure that the airbag system functions correctly.

## Airbag fault warning light

- The airbag system is monitored by the ECU and has a self-diagnostic function. The system status is indicated by the warning lights on the instrument cluster.
- With the ignition on, if the airbag warning light stays on for about five seconds and then disappears, the system is running smoothly.

### WARNING

- The airbag warning light stays on in the presence of certain system faults. If this light stays on, head to a BYD authorized dealer or service provider for inspection

### WARNING

as soon as possible. Otherwise, airbags may not work properly.

- If the vehicle is exposed to water (wet carpet or vehicle submerged in water) or damaged by water, do not start the vehicle and the low-voltage battery needs to be disconnected. Otherwise, the airbags may deploy, resulting in serious injury or death.

## Airbag Types

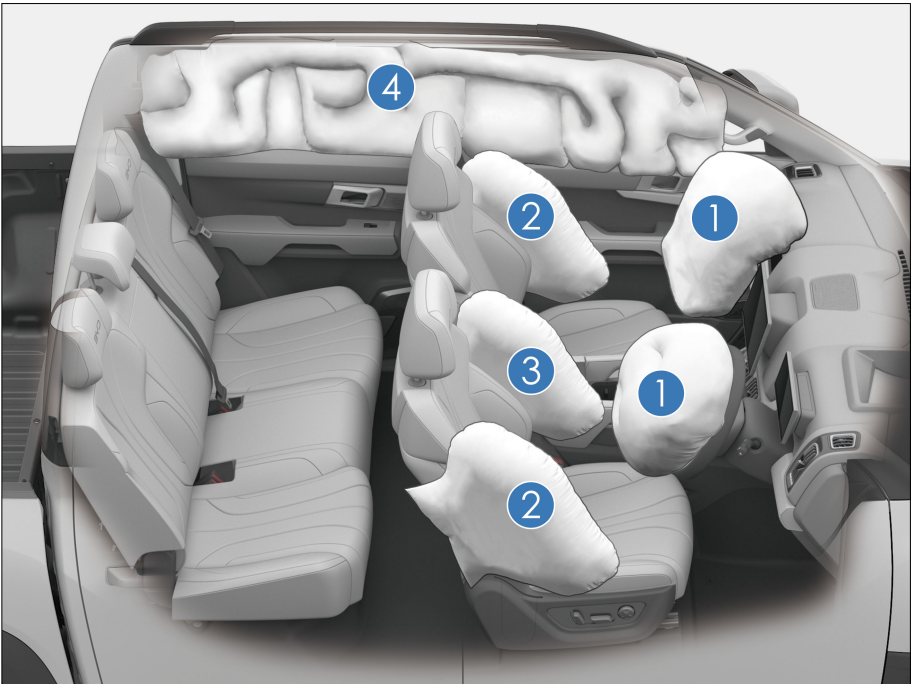

① Driver and front passenger airbags

③ Front far side airbag

## ② Front seat side airbags

**Driver and Front Passenger Airbags**

- The driver airbag is inside the steering wheel and the front passenger airbag is inside the dashboard, both marked with "AIRBAG". The airbags deploy when the airbag system Electronic Control Unit (ECU) detects a moderate to severe front impact and the triggering conditions are met.

**Front airbag deployment**

- In moderate to severe frontal crashes, the sensor sends a signal to the ECU to trigger the front airbags when detecting a sharp deceleration.
- When there is a frontal crash, the seat belt secures the occupant's lower body and torso in place. The airbag cushions and protects the occupant's head and chest.
- When the severity of the impact does not reach the airbag deployment threshold, seat belts provide enough protection.
- The front airbag deflates immediately after inflation, without affecting the driver's vision and ability to operate the steering wheel or other controls.
- A loud noise will be heard when the airbag deploys. It will not cause injury, but it may cause tinnitus or temporary deafness.
- A cloud of dust from the airbag surface may come off when the airbag deploys. Although such powder is non-toxic, individuals with respiratory problem might experience some temporary discomfort.

**! WARNING**

- No accessories, such as telephone holders, cups, and ashtrays, can

## ④ Side curtain airbags

**! WARNING**

be installed on airbag covers or within their impact range. Otherwise, airbag deployment will increase the risk of injury in an accident.

**Front far side airbag**

- The front far side airbag is mounted on the inner side of the driver's seatback and marked with "AIRBAG". When a moderate to severe front or side impact is detected during vehicle travel and the triggering conditions are met, the far side airbag deploys to protect the heads and shoulders of the driver and the front passenger.

**! WARNING**

- Do not wet the seatbacks, in case the front far side airbag system may not work properly.
- Do not cover or replace seatback covers on your own. Unsuitable seatback cover replacements or covers may prevent airbag deployment in a collision.

**! CAUTION**

- If the impact occurs on the front passenger's side, the far side airbag deploys even if there is no passenger in the seat.
- For optimum protection from the driver far side airbag, the occupant must have the seat belt fastened and sit in an upright position.

## Seat Side Airbags

- The front seat side airbags are mounted on the outside of front seatbacks, marked with "AIRBAG" at both sides. When a moderate to severe side impact is detected during vehicle travel and the triggering conditions are met, the side airbag deploys to protect the occupant's chest.

### WARNING

- If the seatbacks get wet from rain or splashes, the side airbag system may not work properly.
- Do not cover or replace seatback covers on your own. Unsuitable seatback cover replacements or covers may prevent airbag deployment in a collision.

### CAUTION

- In the event of a side impact, the airbag on the impacted side deploys when the airbag system meets its deployment conditions.

## Side Curtain Airbags

- The left and right side curtain airbags are mounted at the junctions of the side wall and the ceiling, marked with "AIRBAG" on the B and C pillars. When a moderate to severe side impact is detected during vehicle travel and the triggering conditions are met, the curtain airbag on the struck side deploys to protect the head of the occupant.

### CAUTION

- For optimum curtain airbag protection, the occupant must be

### CAUTION

buckled up and sit in an upright position.

## Airbag Triggering Conditions and Precautions

### Airbag Triggering Conditions

- Airbag triggering conditions: The airbag system may be triggered in certain collisions. Whether a vehicle collision will trigger the airbag(s) is decided by factors such as the amount of collision energy, accident type, collision angle, obstacles and vehicle speed.
- The airbag system does not always work in any accident, and generally it will not be triggered in the event of a minor frontal collision, rear collision or rollover. In this case, the driver and passengers are protected by their properly fastened seat belts.
- Determinants of airbag system triggering: The electronic control unit (ECU) captures the deceleration curve and other signals of the vehicle during a crash. If they are lower than the threshold values set in the ECU, the airbag system will not be triggered even if the vehicle is seriously deformed in the accident.
- The ECU of the BYD airbag system has been set up with considerations of common misuse and road conditions. However, due to the increasing changes in causes and forms of vehicle collisions, for your safety, please strictly follow this user manual, use the vehicle correctly, and avoid its misuse. Otherwise, there is no guarantee that the airbags will achieve their expected effect.



### Cases When Airbags May Be Deployed

- ① The vehicle's nose hits the ground when crossing a deep groove.
- ② The vehicle hits a bump or curbstone.
- ③ The vehicle's nose hits the ground when going down a steep slope.
- ④ One side of the vehicle is hit by another vehicle.

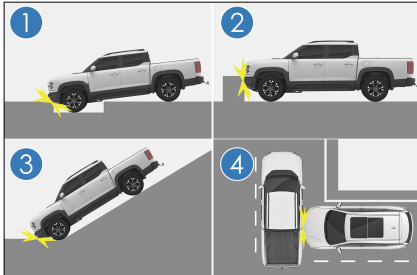

### Cases When Airbags May Not Be Deployed

- ① The vehicle hits a concrete column, tree, or other slim objects.
- ② The vehicle goes under a truck or another large vehicle.
- ③ The tail of the vehicle is hit by another vehicle.
- ④ The vehicle hits a wall or a vehicle at a side other than the front side.

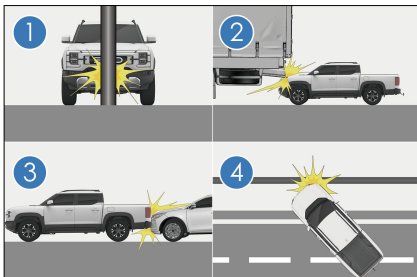

- ⑤ Parts other than the passenger compartment receive side impact.

- ⑥ The lateral side of the vehicle is hit diagonally.

- ⑦ The lateral side of the vehicle hits a columnar object.

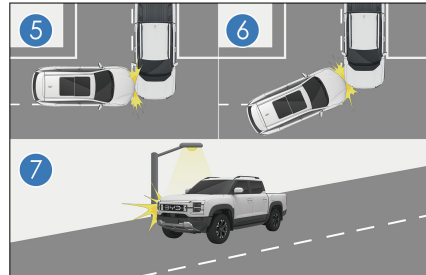

### ⚠ WARNING

- Airbags are designed for specific models. Any changes to suspension, tire size, bumpers, chassis and factory-equipped devices may adversely affect the airbag system. Never use any parts of the airbag system on other vehicles; this may lead to failure of the airbag system and even the personal injury.
- Drivers should maintain a distance of at least 25 cm between their chest and the steering wheel, in order for the system to provide the most effective driver protection.
- Fasten your seat belt and sit properly while the vehicle is in motion. If the seat belt is not fastened, and the occupant is leaning forward or sitting improperly, airbag deployment can increase the risk of injury.
- Do not install, place, affix or cover any accessories near airbags or their deployment areas, such as the the cover of the steering wheel, surface of the dashboard at and near the location of

 **WARNING**

the airbag, windows, pillars, and ceiling. Otherwise, serious injury or even casualty may be caused in case of an accident.

- Clean airbag surfaces with a dry or damp cloth, without applying too much pressure.
- A child is not to be seated in the front passenger seat, nor are they to ride sitting on a front passenger's lap, to prevent serious injury or even casualty caused by airbag deployment in an accident.
- Side airbags and side curtain airbags deploy quickly with high impact forces. Occupants must not lean against the doors of vehicles equipped with these airbags while these vehicles are in motion. Failure to do so could result in serious injury or even death.
- When transferring vehicle ownership, make sure to pass on all of the vehicle's documents and keep the new ownership informed of airbag conditions and replacement dates.
- Do not modify or replace seats or trims of the seats with side airbags. These changes may prevent normal deployment of side airbags, and thereby cause airbag system failure or unintended deployment of side airbags, resulting in serious injury or death.
- Do not disassemble or repair the trims of A, B, C pillars and the ceiling, which contain side curtain airbags. These changes can cause failure of the airbag system or

 **WARNING**

accidental deployment of curtain airbags, which may cause serious injury or even death.

- Do not change any component of the airbag system, including its labels. It is recommended that any operation done to the airbags be performed by a BYD authorized dealer or service provider.
- Airbags only provide one-time accident protection. Once the airbag is triggered or damaged, the airbag system must be replaced.
- Follow safety regulations and procedures related to the scrapping of parts of the vehicle or its airbag system.
- The airbag system has strong anti-interference and anti-disturbance ability to electromagnetic fields around. However, to avoid accidents, do not use the vehicle in an electromagnetic environment that violates national regulations.
- The airbag system of this vehicle is designed with full consideration of common misuses and road conditions. However, in order to avoid accidents, do not have the bottom of the vehicle impacted or drive roughly in harsh road conditions.
- This vehicle's airbag system has been fully verified to seamlessly match the vehicle's original wiring harness system. Any wiring harness modification or alteration may cause the airbags to deploy mistakenly under normal conditions or fail to deploy in the event of a collision.

It is recommended to contact a BYD authorized dealer or service provider immediately if any of the following situations occurs.

- The airbag has deployed.
- Instrument cluster airbag warning light  lights up abnormally.
- The collision with the front of the vehicle (highlighted area shown), but the airbags do not deploy.

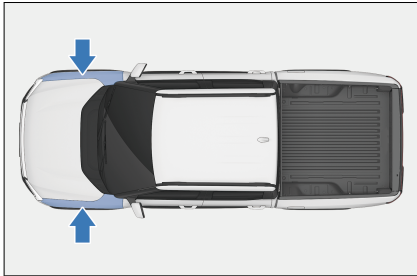

- The airbag cover (highlighted area shown) has been scratched, cracked or otherwise damaged.

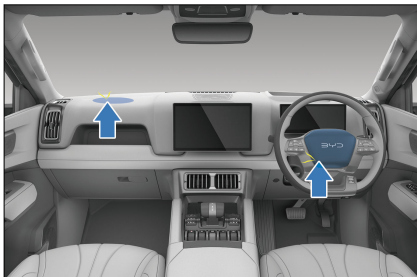

- The collision with the vehicle door (highlighted area shown) is not adequate to cause the airbag to deploy.

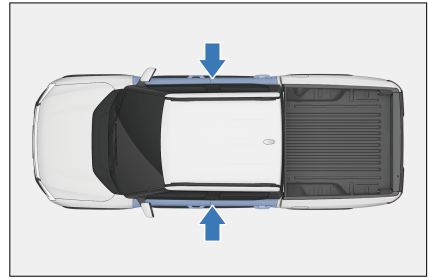

- Airbags need to be removed, disassembled, installed or repaired.
- The surface of the seats with a side airbag is scratched, cracked, or damaged similarly.
- Decorative (liner) parts with built-in curtain airbags at roof beam or C-pillar are scratched, cracked, or damaged similarly.

## Child Restraint System

### Child Restraint System

Child restraint systems provide good protection to your child in an accident. For the child's safety, please carefully read the instructions provided with the child restraint and in this manual before installing a child restraint.

#### WARNING

- Never carry a child on your lap in a vehicle journey.
- An appropriate child restraint system must be used for your child.
- Please follow the instructions provided with the child restraint system and in this manual to

**! WARNING**

make sure the child restraint is properly installed in the vehicle.

- After the child restraint is dismantled from the seat, store it safely in your vehicle.
- Failure to follow the instruction provided with the child restraint and in this manual may cause injuries and even death to your child in an accident.

Children must use a suitable child restraint when traveling in the vehicle. Children should sit comfortably and safely. Make sure that the child restraint is positioned, mounted, and used correctly.

**Important considerations for selecting a child restraint system**

- The child restraint system is the correct type and size for the child.
- The child restraint system is the correct type and size for the seating position.
- The child restraint system must be homologated by ECE R44/ECE R129.

**! WARNING**

- Never install a rear-facing child restraint on the front passenger seat.

**Child Restraint System Anchorages**

The vehicle is equipped with International Standards Organization Fix(ISOFIX). Secure the top tether when installing the child restraint system.

**Rear outboard seat**

- The rear outboard seats are equipped with ISOFIX anchorages. (A label indicating the anchoring position is attached to the seat.)



- The outboard rear seats are equipped with top tether strap anchorages on the rear bulkhead, behind the rear seat.

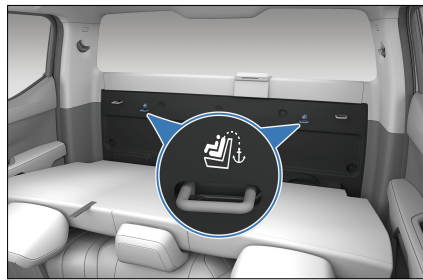

**! WARNING**

- Where applicable to use a top tether strap with the child restraint system, ensure the strap is routed through the hole in the head support before attaching and tensioning the strap to the anchorage point at the base of the seat.
- Do not secure a child restraint on the rear middle seat.
- Child restraint anchorages are designed to withstand only those loads imposed by correctly fitted child restraints. Under no circumstances are they to be used for adult seat belts, harnesses, or for attaching other items or equipment to the vehicle.

**! REMINDER**

- The lower anchorages are located in the gap between the seat cushion and the seatback.

**Installing Child Restraint Systems**

1. Check the position of the special anchorage and install the child restraint on the seat.

**! WARNING**

- When using the lower anchoring device, make sure that no foreign objects are around the anchoring device and that the seat belt is not stuck behind the child restraint; make sure that the child restraint is securely fixed. Otherwise, emergency parking or an accident may result in serious or even fatal injury to the child.

2. Lift the head support, unlock the seatback straps, turn the seatback forward at an angle, and engage the hook tightly to the anchorages under the rear windshield. Then, lock the seatback and tighten the top tether to ensure the tether strap is attached securely.

- ① Top tether
- ② Snap hook
- ③ Anchorage

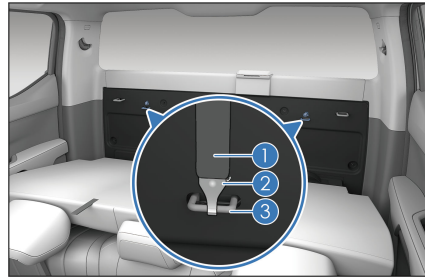

3. Adjust the head support to a proper position.

**! REMINDER**

- If the child restraint system is equipped with a top tether, secure the tether to the anchorage.

**! CAUTION**

- Push/Pull the child restraint in different directions to ensure it is securely installed.
- If the driver's seat obstructs the correct installation of the CRS, install it on the seat behind the front passenger seat.

**Always follow the instructions below when using a child restraint on a rear seat:**

- If there is no front passenger, the front passenger seat can be adjusted to make sure there is enough space for the rear child seat.
- The head support can be adjusted or even removed to ensure that the vehicle seatback can safely support the child restraint system.
- When a child restraint is without seatback, never remove the head restraint from the vehicle and adjust it to locking position.

- When the top tether is used on a second-row outboard seat, route it at the outside of each head support post.

Details on child restraint system installation:

- ① Driver seat
- ② Front passenger seat
- ③ Rear left seat
- ④ Rear center seat
- ⑤ Rear right seat

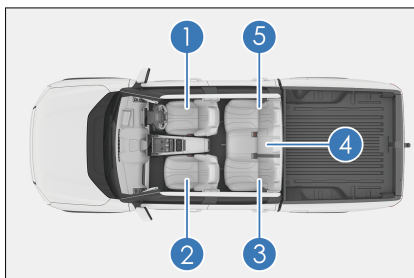

**Seat belt, ISOFIX or i-Size CRS installing options in the vehicle**

Type	Seating Position					
	1	2	3 <sup>b)</sup>	4 <sup>b)</sup>	5 <sup>b)</sup>	
Seating position suitable for universal belt	No	No	No	Yes	No	Yes
i-Size seating position	No	No	No	No	No	No
Seating position suitable for lateral fixture	No	No	No	No	No	No
Largest suitable rearward-facing fixture	No	No	No	R1/R2X/R2/R3	No	R1/R2X/R2/R3
Largest suitable forward-facing fixture	No	No	No	F2X/F2/F3	No	F2X/F2/F3
Largest suitable booster fixture	No	No	No	B2/B3	No	B2/B3

Type	Seating Position				
	1	2	3 b)	4 b)	5 b)

a) If needed, adjust the seat position and seatback angle.

b) If needed, the headrest can be adjusted or even removed. The front seats can be adjusted to ensure the child is not in contact with them.

## Working Modes of Dual-Mode

### Introduction of Dual-Mode System Working Mode

#### EV-All-electric Mode

- In all-electric mode, the high-voltage battery provides electricity to the motor to drive the vehicle in a variety of driving conditions, such as starting, reversing, idling, accelerating, driving at a steady speed, etc.

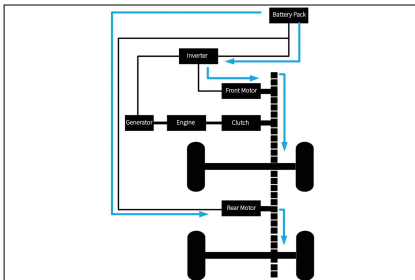

#### ! REMINDER

- The vehicle may switch to HEV mode automatically under operating conditions such as rapid acceleration, high vehicle speed, grade climbing, too high or too low temperature, or low SOC level. Switch to EV mode manually if needed when EV conditions are

#### ! REMINDER

met. It is recommended to choose HEV mode in too high or too low temperatures.

#### HEV-Dual-Mode

- In HEV mode, when the SOC level is high or the power demand is low, the engine does not start, and the vehicle prioritizes all-electric driving mode.

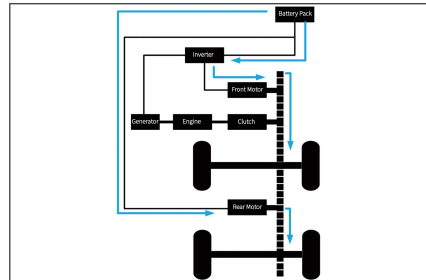

- In HEV mode, when the SOC level is low or the power demand is high, the engine starts and operates in series to meet the power demand.
- In HEV mode, the engine supplies power for battery charging and motor drive.

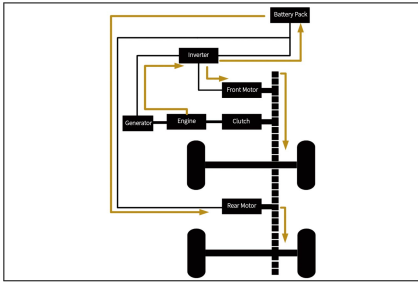

- In HEV mode, the engine and the high-voltage battery simultaneously supply power for motor drive.

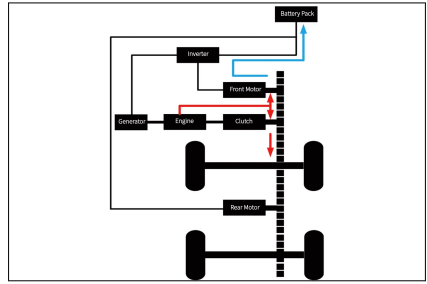

- In HEV mode, the engine drives the vehicle and the motor rests.

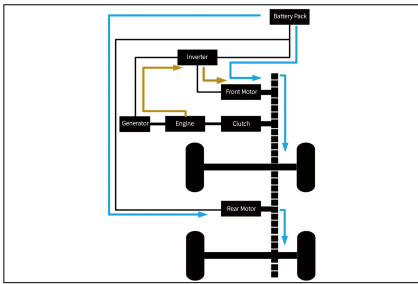

- In HEV mode, the engine starts to operate in parallel at medium and high speeds under some working conditions to improve fuel economy.
- In HEV mode, the engine and drive motor work together to drive the vehicle.

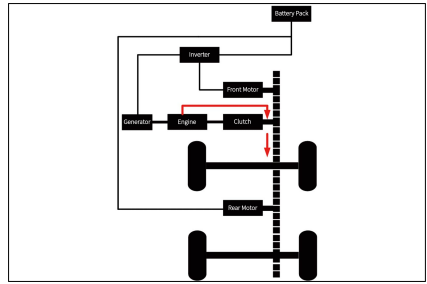

## Working Mode Selection of Dual-Mode System

- Press the button shown in the illustration to switch the "EV/HEV" mode.

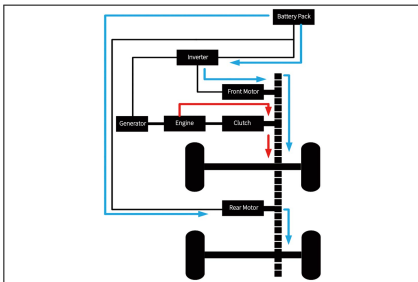

- In HEV mode, the engine drives the vehicle and simultaneously drives the motor to generate electricity for energy recycling.



### EV-ECO Drive Mode

- Press the "EV/HEV" button, and the EV indicator on the instrument cluster lights up, indicating that the whole



vehicle is in EV mode. Turn the scroll button on the left of the steering wheel until the "ECO" indicator on the instrument cluster lights up, indicating that the vehicle is in Ecology, Conservation, Optimization (ECO) to minimize battery power consumption.

### EV-NORMAL Drive Mode

- Press the "EV/HEV" button, and the EV indicator on the instrument cluster lights up, indicating that the whole vehicle is in EV mode. Turn the scroll button on the left of the steering wheel until the "NORMAL" indicator on the instrument cluster lights up, indicating that the vehicle is in NORMAL mode to balance comfort and battery power consumption.

### EV-SPORT Drive Mode

- Press the "EV/HEV" button, and the EV indicator on the instrument cluster lights up, indicating that the whole vehicle is in EV mode. Turn the scroll button on the left of the steering wheel until the "SPORT" indicator on the instrument cluster lights up, indicating that the vehicle is in Sport (SPORT) to ensure better dynamics.

### HEV-ECO Drive Mode

- Press the "EV/HEV" button, and the HEV indicator on the instrument cluster lights up, indicating that the whole vehicle is in HEV mode. Turn the scroll button on the left of the steering wheel until the "ECO" indicator on the instrument cluster lights up, indicating that the vehicle is in ECO mode to provide the best fuel economy.

### HEV-NORMAL Drive Mode

- Press the "EV/HEV" button, and the HEV indicator on the instrument cluster lights up, indicating that the whole vehicle is in HEV mode. Turn the scroll button on the left of the steering wheel until the "NORMAL" indicator on the instrument cluster lights up, indicating that the vehicle is in NORMAL mode to balance comfort and fuel consumption.

### HEV-SPORT Drive Mode

- Press the "EV/HEV" button, and the HEV indicator on the instrument cluster lights up, indicating that the whole vehicle is in HEV mode. Turn the scroll button on the left of the steering wheel until the "SPORT" indicator on the instrument cluster lights up, indicating that the vehicle is in SPORT mode to provide the best dynamics.

### MAX EV Drive Mode

- This mode meets the demand of "using electricity only without fuel", which ensures the pure electric driving of vehicles to the greatest extent.
- If you need to enter MAX EV mode when the battery power is sufficient, press the "EV/HEV" button for about 3s until the "EV" indicator on the instrument cluster shows blue. At this time, the output power is limited to some extent, and when the battery SOC drops to a certain value, the vehicle automatically switches to the "HEV-ECO" mode.

#### REMINDER

- In "MAX EV" driving mode, the power or speed of the whole vehicle is limited to some extent. To improve power, you can switch to "EV" or "HEV" mode.

# Working Mode

## Precautions of Dual-Mode System

**The vehicle operates under the combination of fuel and electricity. Pay special attention to the followings:**

- In low temperature environment, the performance of high-voltage battery will decline. To prevent the high-voltage battery from being damaged, the following protection mechanisms are set:
  - When the temperature is low, the vehicle will limit the charging and discharging power and SOC level.
  - If the temperature is lower than -30 °C or higher than 60 °C, the vehicle cannot be charged.
  - If the temperature is lower than -35 °C or higher than 60 °C, the vehicle cannot be discharged.
  - It is recommended to use vehicles in an environment above -20 °C. In case of the above special environment, it is recommended to use the engine to drive the vehicle.
- The best operating temperature of the battery is 25 °C. When the temperature is too high or too low, the battery limits the output power and shortens the purely electric mileage.

### **Pay Attention to High-voltage and High-temperature Components**

- The high-voltage battery and other high-voltage components of the vehicle are connected by orange cables.

#### **WARNING**

- Do not touch the orange cable or the high-voltage battery

#### **WARNING**

electrode. Electric shock may cause serious or even life-threatening injuries.

- Please read all warning labels.

- The motor, coolant radiator, and some other components may reach high temperatures during driving. These parts are attached with warning labels. Please carefully read and follow the instructions on these warning labels.

#### **WARNING**

- Do not remove or disassemble any high-voltage parts, otherwise serious or even life-threatening injuries may be caused.
- In case of collision, wading and other situations that may cause damage to the high-pressure system, it is recommended to contact a BYD authorized dealer or service provider to avoid the risk of electric shock.
- Do not continue to use the vehicle to avoid the risk of electric shock if the vehicle gives a warning of electric leakage or a BYD authorized dealer or service provider has diagnosed that the vehicle has electric leakage.
- Do not touch parts with high voltage, so as to avoid electric shock caused by improper operation which causes serious or even life-threatening injuries.

- As the vehicle is driven by gasoline engine and motor, the engine sound may be heard from the engine compartment.
- When the vehicle powers up or down, the sound of the high voltage

component (the sound of contactor engagement or disengagement) may be heard under the auxiliary dashboard, which is not a fault.

- If the "OK" indicator lights up, the vehicle can be driven, even if the gasoline engine has not been started (driven by the motor only).
- Be sure to press the "P" button when parking. When "P" or "N" gear is engaged and the SOC is lower than a certain level, the engine may start to charge the high-voltage battery. If the hand-held shift lever is placed in the "N", "R" or "D" gear for too long, it will falsely report that the gear is stuck. Therefore, after the gear is engaged, be sure to release the shift lever. When leaving the vehicle, press the "P" button, take away the key and lock all doors.
- If the low-voltage battery fails and is completely exhausted, even the 12V external power supply cannot be used for jump starts, it is recommended to contact a BYD authorized dealer or service provider.

### WARNING

- Be sure to turn off the powertrain when leaving the vehicle.
- When leaving the vehicle, be sure to press the "P" button, because when the "OK" indicator lights up but the engine stops, the vehicle can idle at a low speed (the motor can drive).
- When the "OK" indicator light is on, the vehicle will travel at a low speed without depressing the brake pedal if the shift lever is placed in the "R" or "D" gear, so please pay attention.

- It is recommended to contact a BYD authorized dealer or service provider for the following situations:
  - Vehicle repair or maintenance is required.
  - If the vehicle cannot be repaired due to accident or other reasons.
  - The vehicle is being handled because of the use of a sealed hybrid low-voltage battery.

### WARNING

- In the event of an accident, perform the following operations to reduce the risk of high-voltage electric leakage.
  - Move the vehicle to a safe place.
  - Depress the brake pedal, press the "P" button, and check that the gear is successfully switched and EPB is engaged.
  - Stop the dual-mode system.
- If the vehicle is severely damaged, there may be a risk of electric shock. To avoid electric shock, do not touch any high-voltage components (such as battery assembly) or cables (in orange) connecting components. If there are uninsulated wires inside or outside the vehicle, do not touch them to avoid electric shock.
- If the liquid leaks into some parts of the vehicle, do not touch the liquid, because it may be the electrolyte of the low-voltage battery. If the fluid contacts the skin or eyes, flush with plenty of water (preferably boric acid solution) and seek medical attention to avoid severe injury.
- If the vehicle catches fire, use a electric fire extinguisher to

## **WARNING**

extinguish the fire. Using only a small amount of water can be dangerous, so use plenty of water (such as a fire hydrant) or wait for the fire brigade.

- If the vehicle needs to be towed, please select the four-wheel off-ground towing. If the wheels touch the ground during towing, the motor may continue to generate electricity, resulting in electric leakage.

# Anti-theft Alarm System

## Anti-theft Alarm System

When armed, the system sounds an alarm and triggers turn signal flashes when any door or hood is opened.

### Arming the system

1. Switch the ignition off.
2. All occupants get off the vehicle.
3. Lock all doors. The anti-theft alarm system will arm automatically after eight seconds. The vehicle's anti-theft alarm system is armed then.
4. Since unlocking the door from inside the vehicle will activate the system, never let anyone stay in the vehicle with the system enabled.

### Triggering the alarm

- The system will raise an alarm in any of the following situations:
  - Any door or hood is opened without using the keyless access function of the smart key.

## Disarming the system

- Anti-theft alarm can be stopped by:
  - Unlocking the door with a valid smart key.
  - Using the microswitch to unlock the door by carrying a valid smart key.
  - Using a valid NFC key to unlock the door.
  - Starting the vehicle remotely with a valid smart key.
  - Pressing the "START/STOP" button inside the vehicle while carrying a valid smart key.

## **WARNING**

- Do not modify the anti-theft alarm system by means of alteration or addition, otherwise the system may fail.

# Data Collection and Processing

## Data Collection and Processing

- This section provides you with some important information on how personal data is collected and processed when you use a BYD vehicle.
- For a more detailed overview on data processing, data protection and data subject rights, please refer to the current version of the privacy policy for the vehicle available at the infotainment system ( → System → System → Privacy policy).
- This vehicle is equipped with an Event Data Recorder(EDR) system. EDR mainly records data in the

event of a crash or near-crash (for example, airbag deployment or hitting on a roadside obstacle) to help comprehend the vehicle system operation, such as:

- Vehicle velocity
- Tire pressure condition
- Adaptive cruise control (ACC) system status
- Whether the seat belt is fastened
- The vehicle records EDR data only when there is a crash or when a near-crash event reaches a certain extent. The EDR does not record any data during the normal driving of the vehicle.
  - The data recorded by the EDR system provides an understanding of the state of the vehicle's safety-related systems when an accident occurs, so that relevant parties can analyze the accident.
  - The EDR data needs to be accessed and read by special equipment. BYD discloses your personal data to third parties only if this is legally permissible or you have consented to it. In addition to the vehicle manufacturer, third-party agencies with professional equipment (such as government agencies) can also read the EDR data if they have access to the vehicle EDR and equipment (for example, they can read the data of SRS control unit to clarify the accident).

### Vehicle Data Processing

- Data is collected when the vehicle is used, such as data collected or transmitted by vehicle sensors or control units, which is necessary for the safe functioning of your vehicle.

- In some cases, the data is used to support driving (driver assistance systems) or to enable a specific comfort or infotainment function.
- Personal data that is collected and processed mainly include in-vehicle data, remote-services-related data, and other data, as further specified below.

### In-vehicle data

#### Operation data

- When the vehicle is used, various vehicle status data (e.g., speed, battery level, and braking system) or environment (e.g., distance sensors and temperature) data are collected and processed.
- This data is not usually stored, but there are control units, sensors or other components installed in the vehicle that record such data, for example, to record maintenance requirements, error messages, or other information.
- The in-vehicle data will only be stored in the equipment in the vehicle but can be read out via the legally required OBD ("On Board Diagnostics") interface, for example, by BYD authorized dealer or service provider or other third parties.
- In case this access takes place during vehicle maintenance, the information can also be transmitted to BYD engineers for quality assurance, product defect reports, or customer claim verification.

### Remote-services-related data

#### Remote monitoring services

- The vehicle has remote monitoring services. These include remote diagnosis and over-the-air (OTA) updates and upgrades for security and

safety purposes (subject to owner's approval).

- These monitoring services serve the following purposes: service provision (remote support/diagnostics), product development, and security/public safety.
- Depending on the country and setup, various vehicle information can be transmitted to BYD's data center in corresponding market for the above purposes, including vehicle location information, vehicle status, such as energy consumption, vehicle speed, gear position, power mode, ESC status, steering system status, battery status, powertrain status, and overall vehicle performance status.

## Other

### Infotainment system

- Depending on vehicle configuration, data can be added to the infotainment system by the users themselves, such as media data for playing video on the infotainment system, address data for use in the navigation system, or data for use in online services.
- Depending on vehicle configuration, individual settings in and on the vehicle can also be entered.
- Data stored in the vehicle can be deleted at any time.
- BYD has no control over data transferred to third parties (from the use of third party content, in particular as part of online services).

### Integration of mobile devices

- Depending on vehicle configurations, mobile devices can be connected and controlled through the vehicle's infotainment system.
- It may be necessary that the device's screen or audio is displayed/played

through the infotainment system or transmitted to it.

- Additional data like positioning or vehicle information can be transmitted through applications for use in certain navigation systems, communication, or other third-party services.
- The specific type of data processing depends on the respective function and is controlled by the user or third parties such as the provider of the devices or corresponding services.

### Internet access and connected services



- Depending on vehicle configurations, the Internet can be accessed for certain functions or BYD services through the vehicle's infotainment system network devices.
- BYD is not liable for any such services provided by any other party.
- In such cases, please obtain information about the use of data from the provider of the respective online service.

### Camera image recording/surrounding area monitoring

- Your vehicle is equipped with a number of cameras/sensors.
- The reason for this is that some vehicle functionalities require the vehicle's path to be detected and assessed which is done by cameras that detect objects in the vehicle's surroundings (e.g., obstacles).
- The images are transmitted to the respective control module for further analytics required to operate the systems.
- Some images are just processed on a volatile basis (RAM), others may be stored, depending on vehicle equipment.

- The vehicle may be equipped with an outward-facing camera (OFC) that can be used to take footage of the surrounding (for example, dashcam).
- The vehicle may also be equipped with an inward-facing camera (IFC), which can be used to take footage inside the vehicle.
- Both OFC and IFC footage is stored.
- You are responsible to check the laws of your residence before turning on your OFC or IFC (for instance, in some countries consent is required for the use of IFC, and in others OFC is strictly restricted to dashcam purposes).
- For more camera details, see section "Panoramic View System" in this manual.

### Permanent Vehicle Transfer to Third Parties and Offline Mode

- In case of a permanent vehicle transfer, i.e., second hand vehicle, or vehicle transfer by a third party for permanent use, it must be noted that any personalization/user settings made via the infotainment system (e.g. address list, navigation system, etc.) may be accessed by the new owner.
- You can also restrict your vehicle's communication with the BYD data server and the processing of vehicle-related and personal data by setting the vehicle to offline mode.
- On the infotainment touchscreen, tap  to turn Wi-Fi off.
- This can also be done by  → **System** → **Link** → **WLAN**.

### Disclosure of Personal Data to Authorities

- BYD will not disclose your personal data to third parties unless this is legally permissible or you have consented to it.
- However, subject to applicable laws, government agencies may be authorized to read out data from vehicles (for example, data can be read from the airbag control unit to clarify an accident).
- If required by law, BYD may also be obliged to disclose data upon request to governmental authorities in your country, such as in the investigation of a criminal offence.

### Your Data Protection Rights

- BYD has staunch respect for its customer's privacy, and strictly complies with all data protection laws, in particular the General Data Protection Regulation (GDPR) and applicable local laws.
- According to these laws, owners have specific rights when their personal data is processed:
  - Data subjects have the right of information, access, rectification, erasure of personal data ("right to be forgotten") and the right to object to and restrict the processing of personal data (or to withdraw consent given earlier, as well as the right to data portability).
- These rights may be limited in some cases, for example, if we can show that we have a legal obligation to process your data, if providing the information to you would disclose personal data about another person, or if we are legally prevented from disclosing that information.

- In some of these cases, we can retain the data even if you withdraw your consent.
- For more information on data processing, data protection, and any rights you may have, please visit the latest version of the Privacy Policy available at the infotainment system (**System → System → Privacy Policy**).



# 02

## INSTRUMENT CLUSTER

Instrument Cluster.....36

# Instrument Cluster

## Instrument Cluster View

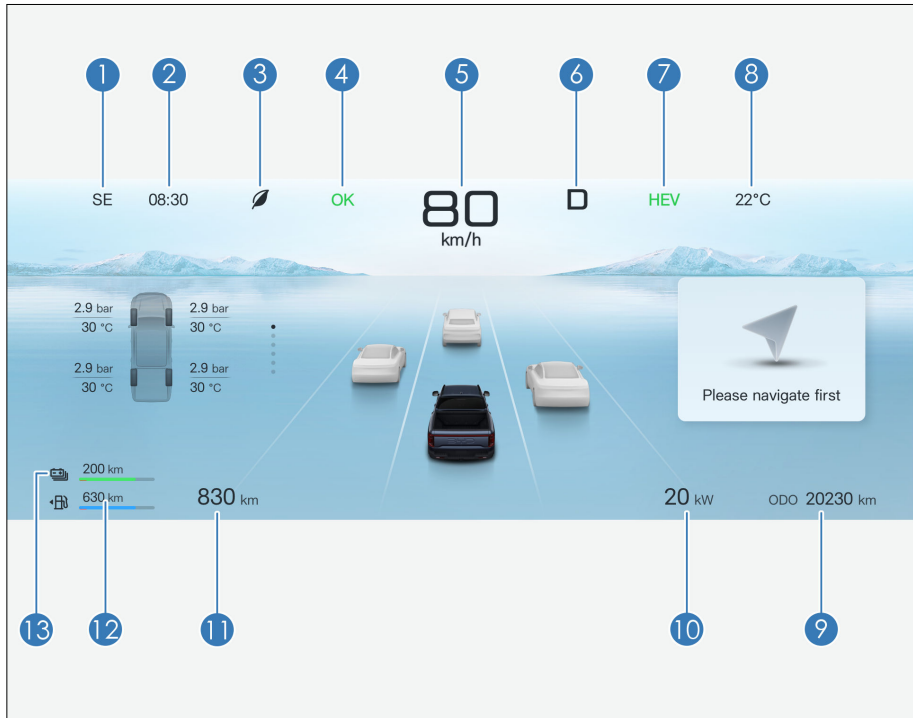

- |   |              |    |                       |
|---|--------------|----|-----------------------|
| 1 | Direction    | 8  | Outside temperature   |
| 2 | Time         | 9  | Total mileage         |
| 3 | Driving mode | 10 | Power meter           |
| 4 | OK gear      | 11 | Total driving range   |
| 5 | Speedometer  | 12 | Fuel gauge            |
| 6 | Gear status  | 13 | State of charge (SOC) |
| 7 | Dynamic mode |    |                       |

**! REMINDER**











- During occasional communication delays in the instrument cluster system, the instrument cluster may automatically switch to simple mode for safe driving. In this mode, the instrument cluster continues to display driving related information normally without affecting normal vehicle travel. After the system becomes normal, the instrument cluster may automatically exit the simple mode. If it does not, try the following actions to switch back to normal mode:
  - Press and hold the scroll button on auxiliary dashboard for three seconds to restart the instrument cluster information display system.
  - While vehicle safety is ensured, operate the vehicle power



























**! REMINDER**



- switch to turn off the vehicle and then turn the ignition on.
- If the instrument cluster remains in simple mode after those actions have been taken, promptly contact a BYD authorized dealer or service provider for inspection.
- The image of the instrument cluster view is for reference only and is subject to actual factory configuration.











## Instrument Cluster Indicators

### Indicators and Warning Lights

Indicator	Name	Indicator	Name
	Turn signal indicator		Position light indicator
	Discharge indicator		OK indicator
	GPF regeneration indicator		Low beam indicator
	EV Indicator		HEV Indicator
	AVH indicator		HDC indicator

	Light switch indicator		Front fog light indicator
	High beam indicator		EV Indicator
	Towing mode indicator		ICC activation indicator
	BSD activation indicator		LSS indicator
	AEB indicator		ACC working indicator
	ELKA urgent avoidance indicator		AVH standby indicator
	Sport mode indicator		Comfort mode indicator
	Economic mode indicator		Snow mode indicator
	Muddy mode indicator		Mountain mode indicator
	Sand mode Indicator		Wade mode indicator
	GPF regeneration fault indicator		Rear fog light indicator
	Low tire pressure warning light		Oil life monitoring indicator
	Smart key warning light		Main alarm indicator

	ESC OFF warning light		ESC fault warning light
	Headlight fault warning light		Engine fault warning light
	ABS fault warning light		High-voltage battery low SOC warning light
	Low fuel warning light		BSD fault indicator
	LSS fault warning light		LSS off indicator
	AEB fault warning light		TSR fault warning light
	TSR off		ICC fault warning light
	ELKA urgent avoidance fault indicator		ELKA urgent avoidance off indicator
	Driving power limit warning light		CPD warning light
	AEB warning light		Unable to sense speed
	TSR indicator		EPB indicator
	Parking system fault warning light		Seat belt indicator

	Airbag fault warning light		Steering system fault warning light
	Coolant overheating warning light		Low oil pressure warning light
	High-voltage battery charging connection indicator		Low-voltage power system fault warning light
	High-voltage battery overheating warning light		High-voltage battery fault warning light
	Powertrain fault warning light		Motor overheating warning light

### Warning Lights/Indicators Description



#### Emission fault warning light

- With the vehicle powered ON, this indicator is on for self-check. If on at any other time, it indicates that a certain control system of the vehicle may be faulty. Continuous operation in this state may cause serious damage to the vehicle.
- If this warning light lights up when the vehicle is not in self-check, drive the vehicle to the roadside safely, power the vehicle off, and power it on again, start the engine and check this warning light. If this warning light is still on, it is recommended to drive the vehicle to a BYD authorized dealer or service provider for inspection as soon as possible. Before the BYD authorized dealer or service provider finds out the fault, drive with caution and avoid driving at a high speed or fully pressing the accelerator pedal.
- If the warning light lights up frequently, it is recommended to contact a BYD authorized dealer or

service provider for inspection, even if it goes out after the above steps are followed.



#### CAUTION

- Continuous driving after the emission fault warning light turns on may damage the emission control system and the engine.



#### Low fuel warning light

- If on, it indicates little fuel in the fuel tank and reminds the driver to refuel the vehicle as soon as possible.
- When the fuel tank shakes on a slope or curve, the low fuel warning light may be on earlier than usual.



#### Smart key warning light

- If the key is not in the vehicle when you press the START/STOP button, this warning light comes on for a few seconds, a beep sounds, and the message "No key detected, please

confirm if the key is in the vehicle" is displayed on the instrument cluster.

- If you press the START/STOP button while an electronic smart key matching the model is in the vehicle, this warning light does not light up. The vehicle can now be powered on.
- This warning light will disappear if the key is taken into the vehicle within a few seconds after the light turns on.
- If the warning light flashes after you press the START/STOP button, it indicates low battery of the key.



#### ABS fault warning light

- With the vehicle powered ON, this warning light is on for self-check. If the anti-lock braking system (ABS) is working properly, the light goes out in a few seconds. Thereafter, if the system fails, the light lights up again until the fault is cleared.
- When the ABS fault warning light is on (with the parking system fault warning light off), the braking system continues to operate whereas the ABS does not.
- When the ABS fault warning light is on (with the parking system fault warning light off), since the ABS system does not operate, the wheels will be locked in case of emergency braking or braking on a slippery road.
- If any of the following cases occurs, it means there is a fault in components monitored by the warning light system. In that case, contact a BYD authorized dealer or service provider for vehicle inspection as soon as possible.
  - This warning light does not come on or is steady on when the ignition is on.
  - This warning light turns on during driving.

#### ! REMINDER

- A warning light that lights up briefly during operation does not indicate a problem.
- If the ABS fault warning light is still on while the parking brake system fault warning light is on, it is recommended to immediately park the vehicle in a safe place and contact a BYD authorized dealer or service provider. In this case, if brakes are applied, the ABS will not work and the vehicle will become extremely unstable.
- The ABS has a self-check function. If any malfunction occurs, the ABS fault warning light turns on. This means the ABS fails. At this time, the brake still provides normal braking force like a conventional vehicle without anti-lock braking function, and the front or rear axle may lock up under large braking force, which will easily lead to steering failure or tail flick. Especially when this fault occurs in rainy and snowy weather, do not depress the brake pedal deeply to avoid losing control of the vehicle. At the same time, it is recommended to contact a BYD authorized dealer or service provider to check the vehicle as soon as possible.
- If both the ABS and parking system warning lights go on after the electronic parking brake is fully released, it indicates that the braking force distribution system of the front and rear tires has also failed.
- If the brake pedal feels abnormal, take measures immediately. The braking system is dual-circuited, so partial failure cannot prevent the other two wheels from braking. In such a situation, you need to press the brake pedal further to slow the vehicle, and

braking distance is longer. Decelerate the vehicle and safely move it to the roadside. A longer braking distance can present serious driving hazards, so the vehicle must be towed away for immediate repair.

- If you have to drive a short distance under such conditions, proceed at low speed with extreme caution.



#### Low tire pressure warning light

- This warning light comes on when the ignition is on. It turns off in a few seconds if the tire pressure monitoring system is working properly. Thereafter, if the system fails, this warning light turns on again.
- When the low tire pressure warning light comes on or flashes, the message "Please check the TPMS" is displayed on the instrument cluster, and the tire pressure is displayed as "---", it indicates that the tire pressure system is faulty.
- When the tire pressure value displays "No Signal", it indicates that the tire pressure signal at this location of the vehicle may be disturbed or the tire pressure monitoring module is damaged.
- When the low tire pressure warning light is solid on and one or more values turn yellow on the tire pressure screen on the instrument cluster, the corresponding tire is in under-pressure condition. When the temperature value of one or more tires turns yellow, it indicates that the tire temperature is too high.

In the event of any of the situations above, it is recommended to contact a BYD authorized dealer or service provider for inspection as soon as possible.



#### ESC fault warning light

- This warning light comes on when the ignition is on. If electronic stability control (ESC) functions properly, the light goes out in a few seconds. If the system fails, this warning light turns on again until the system fault is cleared.
- A flashing fault warning light during driving indicates that the ESC system is working.
- When the ESC fault warning light turns on (with the ABS fault warning light and the parking system fault warning light off), the ESC fails, but the ABS and the braking system continue to operate normally.
- When the ESC warning light turns on (with the ABS fault warning light and the parking system fault warning light off), the ESC system does not work. This means the vehicle is extremely unstable at sharp turns or when the driver steers away from obstacles ahead.
- If any of the following cases occurs, it means there is a fault in components monitored by the warning light system. In that case, contact a BYD authorized dealer or service provider for vehicle inspection as soon as possible:
  - When the ignition is switched on, this warning light remains off (self-check not performed within 5s) or is solid on after the ignition is switched on.
  - This warning light stays on during driving.



#### REMINDER

- A warning light that lights up briefly during operation does not indicate a problem.



### ! REMINDER

- If the ESC fault warning light remains on while the fault warning lights for the ABS and the parking system are on, immediately stop the vehicle in a safe place and contact a BYD authorized dealer or service provider. In this case, if brakes are applied, the ABS will not work and the vehicle will become extremely unstable.



#### ESC OFF warning light

- With the ignition on, this warning light turns on for a few seconds and then disappears.
- When the "ESC OFF" switch is turned on, the light should remain steady on and the ESC system will not operate. When the "ESC OFF" switch is pressed again, this warning light should turn off and the ESC system resumes its normal operation.

### ! REMINDER

- Once the ESC OFF warning light is on, the driver must stay alert and drive at a low speed when making a sharp turn or avoiding obstacles which appear suddenly, because ESC system is turned off at this time and braking will cause instability.



#### Driving power limit warning light

- When the power of the vehicle is limited, this warning light will light up, and it is recommended to contact a BYD authorized dealer or service provider in time.



#### Seat belt indicator

- With the ignition on, if any seat belt is not fastened, the corresponding seat belt indicator will light up. It remains on until the seat belt is fastened.



#### Airbag fault warning light

- With the ignition on, this warning light turns on and then off after a few seconds if the airbag system is working properly. This warning light is used to monitor the airbag ECU, collision sensors, inflation device, warning lights, connections, and power supply.
- If any of the following cases occurs, it means there is a fault in components monitored by the warning light system. In that case, contact a BYD authorized dealer or service provider for vehicle inspection as soon as possible.
  - When the ignition is switched on, this warning light remains off or is solid on after the ignition is switched on.
  - This warning light turns on or flashes during driving.



#### Parking system fault warning light

If any of the following conditions occurs, immediately park the vehicle in a safe place. It is recommended to contact a BYD authorized dealer or service provider.

This warning light lights up in the following conditions:

- This warning light comes on when the ignition is switched on and the brake fluid level is low.

### REMINDER

- When the brake fluid level is low, park the vehicle because it is dangerous to continue driving.
- When the engine is running, this indicator is solid on if the brake fluid level and EPB system operation are normal (the EPB is engaged and released normally, and the message "Please check the EPB" is not displayed).
- The parking system fault warning light stays on with the ABS fault warning light. In this case, the braking system or the EPB may not work normally, lengthening the braking distance. Therefore, during braking, the ABS does not function, and the vehicle is unstable. Proceed with caution.
- Momentary illumination of this warning light during operation does not indicate a problem.

### CAUTION

If any of the following conditions occurs, immediately park the vehicle in a safe place. It is recommended to contact a BYD authorized dealer or service provider.

- When the engine is running and the light is still on, the brake may malfunction, resulting in extended stopping distances. Firmly depress the brake pedal to initiate an emergency stop.



! Steering system fault warning light

- When the steering system is faulty and this warning light is steady on, it is recommended to bring the vehicle to

a BYD authorized dealer or service provider for inspection.

### REMINDER

- The steering system features an electric motor to reduce the force required to turn the steering wheel.
- When turning the steering wheel, a hum may be heard from the running motor. This does not indicate that the motor is faulty.
- Do not turn the steering wheel to its limit position for more than five seconds, otherwise the temperature protection will be activated and the steering system will be damaged or steering will become heavy.
- If you have turned the steering wheel frequently with the vehicle staying put for a long time, the steering wheel may become difficult to turn even if the warning light does not turn on. This is not a fault.
- To prevent steering system overheating, the power assist effect will be reduced if the steering wheel has been frequently turned with the vehicle staying put for a long time. As a result, the steering wheel become difficult to turn. In this case, reduce steering frequency, or power off the vehicle and turn off the engine. The system will recover within 10 minutes.

### WARNING

- If the steering system fault warning light goes on, immediately park the vehicle safely, and contact a BYD authorized dealer or service provider.



### Coolant overheating warning light

- With the ignition on, this light indicates that the coolant temperature is high. It is recommended to park the vehicle to cool it down. In harsh conditions, like hot season and long periods of hill climbing and high speed driving, the engine may overheat.



### Low oil pressure warning light

- This light is about warning of low oil pressure. If this warning light flashes or remains on during driving, drive off the road, park the vehicle in a safe place, and shut down the engine immediately. It is recommended to contact a BYD authorized dealer or service provider for help.
- When the engine is idling, this warning light may flash occasionally, or go on momentarily after emergency braking. When the engine is accelerating gradually, if this indicator goes out, the oil pressure is normal.
- This warning light goes on in case of very low oil level.



### CAUTION

- Do not drive the vehicle when the warning light is on, even for a short distance. Otherwise, the engine is damaged.



### Low-voltage power system fault warning light

- If this warning light turns on while driving, it indicates that there is a problem with the charging system, DC system, or low-voltage power supply system. The engine can continue igniting until the battery runs out.

In this case, turn off the A/C, fan, and the infotainment touchscreen, and drive the vehicle to the nearest BYD authorized dealer or service provider for maintenance as soon as possible.



### Powertrain fault warning light

- If the powertrain fails, this warning light turns on.
- If any of the following cases occurs, it means there is a fault in components monitored by the warning light system. In that case, contact a BYD authorized dealer or service provider for vehicle inspection as soon as possible.
  - This warning light is steady on when the ignition is switched on.
  - This warning light turns on during driving.



### CAUTION

- Try not to drive the vehicle when the warning light is on. It is recommended to drive to a BYD authorized dealer or service provider to check the problem as soon as possible.



### High-voltage battery overheating warning light

- If this warning light is on, it indicates that the high-voltage battery temperature is too high and the vehicle must be stopped to cool down. When the warning light flashes, it is recommended to immediately stop the vehicle safely and leave the vehicle as soon as possible.
- The high-voltage battery may overheat under the following operating conditions:

- Driving up a slope for a long time in hot weather
- Long period of stop-and-go traffic condition, frequent rapid acceleration, frequent hard braking, or vehicle running for a long time without pause.



#### High-voltage battery fault

##### warning light

- This warning light comes on when the ignition is switched on. If the high-voltage battery system is working properly, this warning light will turn off in a few seconds. Thereafter, if the system fails, this light will light up again. It is recommended to contact a BYD authorized dealer or service provider for inspection as soon as possible.
- If any of the following cases occurs, it means that there are faults in the components monitored by the warning light system. In such case, it is recommended to contact a BYD authorized dealer or service provider for vehicle inspection as soon as possible.
  - This warning light is steady on when the ignition is on.
  - This warning light is steady on or occasionally turns on while driving.



#### TSR indicator

- When this indicator lights up, it means that the vehicle system has recognized the speed limit value on current road section.



#### Gasoline Particulate Filter (GPF)

##### regeneration indicator

- When the GPF carbon load (particulate matter emission) reaches a certain amount, the GPF will actively regenerate and the GPF indicator is solid green. At this time, try to drive on the highway as much as road conditions allow, and when the particulate matter is cleared, the GPF indicator turns off automatically.



#### Gasoline Particulate Filter (GPF) regeneration fault indicator

- When the GPF carbon load (particulate matter emission) reaches its maximum, fuel consumption increases, power performance decreases, and the GPF indicator is solid yellow. At this time, go to a BYD authorized dealer or service provider for inspection.









#### REMINDER

- If the vehicle is driven in EV mode for a long time, this function starts the engine for maintenance and a prompt is displayed on the instrument cluster: The engine has been started for maintenance.

#### Other Instrument Cluster Fault Prompts

The instrument cluster may display the following fault prompts. Handle them as recommended.

Symbol	Fault Prompt	Response
	Please check the OBC system	The on-board charging system is faulty. In this case, check the charging connection, and reconnect the charging equipment. If the

		fault persists, contact a BYD authorized dealer or service provider.
	Please check the data network of the vehicle.	The vehicle may be disconnected from the data network. In this case, park the vehicle immediately, and contact a BYD authorized dealer or service provider.
	Engine attachment limited	The engine accessories function is faulty. In this case, contact a BYD authorized dealer or service provider.
	Please check the memory system	The memory system is faulty. In this case, contact a BYD authorized dealer or service provider.
	Please check the hill descent control (HDC) system	The HDC system is faulty. In this case, contact a BYD authorized dealer or service provider.
	EV power limited	The EV function is limited. Contact a BYD authorized dealer or service provider immediately.
	Please check the headlight	The headlight is faulty. In this case, contact a BYD authorized dealer or service provider.
	AEB warning light*	The AEB system is faulty. In this case, park the vehicle, and contact a BYD authorized dealer or service provider.
	Please check the BSD system	The blind spot detection system for lane change is faulty. In this case, park the vehicle immediately, and contact a BYD authorized dealer or service provider.
	BSD function limited	The BSD function is limited. In this case, park the vehicle, and contact a BYD authorized dealer or service provider.
	Please check the gear	The shifter controller is faulty. In this case, park the vehicle immediately, and contact a BYD authorized dealer or service provider.
	Please check the multi-purpose camera	The multi-purpose camera is faulty. In this case, park the vehicle, and contact a BYD authorized dealer or service provider.
	MPC function limited	The function of the multi-purpose camera is limited. In this case, park the vehicle, and

contact a BYD authorized dealer or service provider.



The environment limited, the intelligent camera is not available

The intelligent-camera is unavailable. In this case, park the vehicle, and contact a BYD authorized dealer or service provider.

---



Solenoid valve is cleaning. Please wait for a moment.

The solenoid valve is cleaning, please park and wait. If the malfunction exists for a long time, it is recommended to contact a BYD authorized dealer or service provider.

---



Please check the lane departure assist (LDA) system

The LDA is faulty. In this case, park the vehicle as soon as possible, and contact a BYD authorized dealer or service provider.

---

# 03

## CONTROLLER OPERATION

Doors and Keys.....	50
Seats.....	61
Steering Wheel.....	65
Wipers.....	68
Rearview Mirrors.....	70
Switches.....	72

# Doors and Keys

## Keys

The vehicle is equipped with keys, including electronic smart key, mechanical key and NFC key.

### Electronic Smart Key

Press the left or right front door microswitch, while carrying the smart key, to unlock or lock all doors, or press smart key buttons to lock or unlock doors, open the tailgate, or start the vehicle remotely.

- ① Indicator
- ② Lock button
- ③ Unlock button
- ④ Locking/Unlocking the tailgate
- ⑤ START/STOP button
- ⑥ Mechanical key

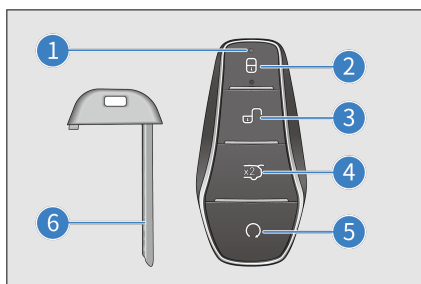

### **WARNING**

#### Button battery safety alert:

- The button (coin) battery in the smart key is hazardous and both new and used batteries are to be kept away from children at all times.

### **WARNING**

- If swallowed or placed inside any part of the body, a lithium button battery can cause severe or fatal injuries in two hours or less.
- Medical attention should be sought immediately if it is suspected the button battery has been swallowed or placed inside any part of the body.

### **CAUTION**

- The smart key is an electronic component. Observe the following instructions to prevent damage to the key:
  - Do not expose the smart key to high temperatures, such as on the dashboard.
  - Do not disassemble the smart key without authorization.
  - Do not let the smart key hit other objects or fall down.
  - Do not immerse the key in water or clean it in the ultrasonic scrubber.
  - Do not place smart keys with devices that emit electromagnetic waves, such as the mobile phone.
  - Do not attach to the smart key any objects (such as a metal seal) capable of cutting off electromagnetic wave signals.
  - You can register a spare key for the same vehicle. In this case, contact a BYD authorized dealer or service provider immediately.
- If the electronic smart key cannot operate the door within the



 **CAUTION**

normal distance, or the key indicator light is dim or off:

- Check for nearby radio stations or airport radio transmitters that interfere with the normal operation of electronic smart keys.
- The smart key battery may be exhausted. Check the battery inside the electronic smart key. It is recommended to contact a BYD authorized dealer or service provider for battery change.
- If you lose your smart key, it is recommended to contact a BYD authorized dealer or service provider as soon as possible to reduce the risk of vehicle theft or accidents.
- Do not change the transmission frequency arbitrarily, increase the transmission power (including additional transmission frequency amplifier), or arbitrarily connect the external detection antenna or switch to other transmitting detection antennas.
- Do not generate harmful interference to legal radio communication services when using the smart key. Once any interference is found, stop using the smart key immediately, and take measures to eliminate the interference before continuing to use it.
- The use of micropower radio equipment must be free from interference of all radio services or from radiation of devices for industrial, scientific and medical applications.

 **CAUTION**

- Do not use it near aircraft or airports.
- People implanted with pacemakers or defibrillators should stay away from the detection antennas of intelligent entry and start systems, as electromagnetic waves can affect the normal use of such devices.
- In addition to people implanted with pacemakers or defibrillators, those who use other electronic medical devices should also consult the manufacturer on the use of such devices under the influence of electromagnetic waves. Electromagnetic waves may bring unknown consequences to the use of such medical devices.
- When leaving the vehicle, always carry your key and lock the vehicle. Never leave anyone (especially children) alone in the vehicle.

### Mechanical Key

Use the mechanical key (inside the smart key) to lock or unlock the driver's door. Insert the mechanical key back into the smart key when it is not in use.

### Taking out the mechanical key

- Press the "PUSH" button ② on the smart key, and take out the mechanical key in the direction indicated by ①.

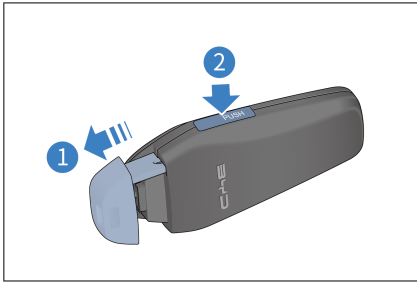

- Press the "PUSH" button and insert the mechanical key back into the smart key when it is not in use.

### NFC Digital Key

- NFC digital key is a function provided by BYD for users. You can register mobile phones or wearable devices as vehicle keys to unlock, lock and start the vehicle.
- Before activating the NFC digital key, observe the following conditions:
  - The vehicle has been equipped with BYD Cloud Service.
  - The vehicle supports NFC digital key.
  - Some mobile phones and wearable devices support BYD NFC digital keys (consult a BYD authorized dealer or service provider for other supported wearable devices).

### Activating the NFC digital key of mobile phone

Before activating, start the vehicle and shift into "P" with a valid smart key. There are three ways (The configuration on your actual vehicle may differ):

- Via BYD App:
  - Please go to the mobile APP store to download BYD APP, and complete registration and login. Tap digital key to enable the function according to the instructions.

- Via email links:
  - Log in to the email account reserved when purchasing the vehicle on the phone, and activate the digital key according to the instructions in the email from bydapp@byd.auto.
- Via the infotainment touchscreen:
  - On the infotainment touchscreen, tap  → **Vehicle** → **Locks** → **Digital key** to activate the key according to the instructions.

### Activating the NFC digital key on wearable devices

Supported wearable devices include Apple Watch (consult a BYD authorized dealer or service provider for other supported wearable devices), and there are two ways for activating:

- Synchronize data to Apple Watch after the successful activation on iPhone:
  - Wear an unlocked Apple Watch and activate the iPhone digital key. After activation, iPhone synchronously prompts to add a digital key on the nearby bound Apple Watch. Activate it according to the instructions.
- Via Watch App:
  - This method is applicable when the iPhone digital key is activated but not synchronized to the Apple Watch. Open the Watch App on the iPhone, select "Wallet", find the corresponding key and tap "Add" to activate the key according to the instructions.

### Using the NFC digital key

When using the NFC digital key, enable the NFC function of the mobile phone or wearable device. Usage:

- Carry a mobile phone or wearable device with a valid NFC digital key, put its NFC antenna area close to the NFC

- sign on the driver's side mirror, and unlock or lock the vehicle. Consult the manufacturers for details of the NFC antenna area.
- Place the mobile phone or wearable device at the NFC sign in the vehicle to obtain the vehicle start permission.

### CAUTION

- With permission, start the vehicle as soon as possible. If the vehicle is not started in time, place the mobile phone or wearable device at the NFC sign again to obtain the permission.

### Removing the NFC digital key

There are three ways:

- Via BYD App:
  - Open BYD App, enter the digital key management page, tap the key to be removed, and enter the operation password to remove it.
- Via the infotainment touchscreen:
  - With a valid smart key, go to the infotainment touchscreen →  → **Vehicle** → **Locks** → **Digital key** to remove the key according to the instructions.
- Via Wallet:
  - Open the Wallet on the phone, select the digital key, and remove it according to the instructions.

## Locking/Unlocking Doors

### Locking/Unlocking with Mechanical Key

Insert the mechanical key into the keyhole of the driver's door handle, turn, and then pull out the mechanical key. Pull on the door handle to open the door.

- Unlock the driver's door: Turn the key counterclockwise.
- Lock the driver's door: Turn the key clockwise.

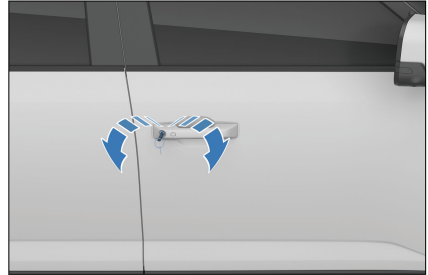

### CAUTION

- After removing the mechanical key, pull the driver's door handle to open the door.

### Opening Doors with Interior Door Handle

- When the vehicle is unlocked, pull the handle once to open the door from inside the vehicle.
- When the vehicle is locked, pull the handle twice to open the door from inside the vehicle.

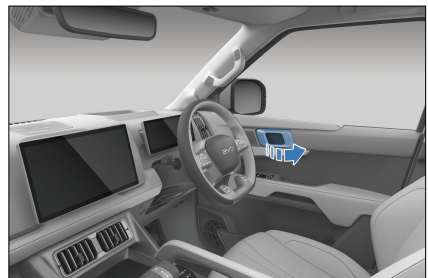

### CAUTION

- As this vehicle is equipped with a child protection lock, the rear

## CAUTION

doors can only be opened with the interior handle when the child protection lock is disabled.

### Locking/Unlocking with Smart Key

- The wireless remote control is used to unlock or lock all doors at a close distance, and complete additional functions.
- When you enter the active area while carrying a registered smart key, press the button on the smart key slowly and firmly to lock or unlock all doors.

#### Locking:

- When all the doors and the hood are closed, press the lock button to lock all the doors. If the vehicle is shut down, the side mirrors will fold (**Side Mirror Auto Fold** is enabled on the infotainment touchscreen →  → **Vehicle** → **Comfortable Use**) with turn signals flashing once. If the ignition has not been switched off, the side mirrors will not fold, the turn signals will not flash, and the alarm will sound once. Check whether all doors are securely locked.



- If a door, the hood or the tailgate is not closed, the turn signals do not flash, and the horn sounds once.

#### Unlocking:

- Press the unlock button to unlock all the doors at the same time. The turn signals flash twice.
- When you unlock all the doors with the smart key, even if no door is opened, the interior lights (the DOOR function can be activated) will stay on for 15 seconds and then go out.
- If the anti-theft alarm system is armed, open any door within 30 seconds after unlocking with the smart key. Otherwise, all the doors will lock automatically.
- If the key is in the vehicle when the doors are closed and locked, the vehicle will unlock automatically and the turn signals will flash twice.

### Finding the Vehicle with Smart Key

- With the anti-theft alarm system armed, pressing the lock button sounds a beep and makes turn signals flash 15 times. Use this function to locate the vehicle when it cannot be found.
- When the vehicle is in car search mode, press the lock button again. The vehicle enters the next car search mode.

### Raising/Lowering Windows with Smart Key

- When the ignition is switched off:
  - Press and hold the lock button on the smart key to raise the four windows.
  - Press and hold the unlock button on the smart key to lower the four windows.

## WARNING

- When using the remote control function to raise windows, pay

### ! WARNING

attention to the safety of occupants in the vehicle, and use this function only after making sure the windows are clear from pinching anyone.

### ! REMINDER

- To enable or disable key unlock/lock functions or opening/closing window functions, go to the infotainment touchscreen →  → **Vehicle** → **Locks**. (Configurations of the actual vehicle prevail.)

## Locking/Unlocking with Microswitch

### Locking

- With the doors closed but not locked, press the microswitch on the front door handle while carrying the smart key. All the doors are locked. If the vehicle is shut down, the side mirrors will fold (**Side Mirror Auto Fold** is enabled on the infotainment touchscreen →  → **Vehicle** → **Comfortable Use**) with turn signals flashing once. If the ignition has not been switched off, the side mirrors will not fold, the turn signals will not flash, and the alarm will sound once.



- If a door, the hood or the tailgate is not closed, pressing the microswitch will still lock the closed doors, but the horn will only sound once, and the turn signals will not flash.

### Unlocking

- When doors are locked, press the microswitch on the front door handle while carrying the smart key. All doors unlock and turn signals flash twice.
- If the anti-theft alarm system is armed, open a door within 30 seconds after the unlocking, or all doors will relock automatically.
- Pressing the microswitch does not work if:
  - This is performed while a door is being opened or closed.
  - The smart key is left in the vehicle.

### ! REMINDER

- If the smart key is too close to an exterior door handle or window, it may not be possible to activate the entry function.

## Raising/Lowering Windows with Microswitch

- When the ignition is switched off, press and hold the microswitch while carrying the smart key to roll up or down all windows. (To enable or disable this function, go to the infotainment touchscreen →  → **Vehicle** → **Locks**.)

## Locking/Unlocking with NFC Key

### Locking doors:

When doors are closed but unlocked, hold the effective NFC key close to the designated area on the driver's side

mirror. All doors can then be locked at the same time. The turn signals flash once when the vehicle is powered off.

### Unlocking doors:

When doors are locked, hold the NFC key close to the designated area on the driver's side mirror. Then all doors can be unlocked at the same time. The turn signals flash twice.

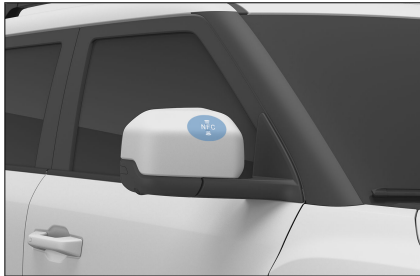

- Putting the effective NFC key close to designated area on the driver's side mirror does not work if:
  - The NFC key is placed close to the designated area on the driver's side mirror while a door is being opened or closed.
- To use the NFC digital key on the phone, enable the NFC function of the phone and hold the top back part of the phone close to the designated area on the driver's side mirror.

### CAUTION

- The NFC digital key may not work on some phones when they are turned off.
- Avoid using the NFC digital key of your phone for extended periods or frequently when it is out of battery or turned off.

### REMINDER

- If the anti-theft alarm system is armed, open a door within 30 seconds after the unlocking with the NFC key, or all doors will relock automatically.
- After unlocking by NFC key, the user can start the vehicle in a certain period, while this will be disabled after locking with valid key.
- For NFC key (smart phone) setup instructions, see **P52** for details.

### Locking/Unlocking the Tailgate

#### Opening the tailgate with smart key

- Double press the tailgate opening button on the smart key to open the tailgate, and the turn signals flash twice.



#### Opening the tailgate from inside the vehicle

- When the tailgate is closed, press the switch once, follow the prompts on the infotainment touchscreen to unlock and open the tailgate.



### Opening the tailgate with exterior pickup bed switch

- With the vehicle unlocked, press the exterior microswitch on the tailgate twice within one second to open it.
- With the vehicle locked, unlock the vehicle with the smart key and press the exterior microswitch twice to open the tailgate.

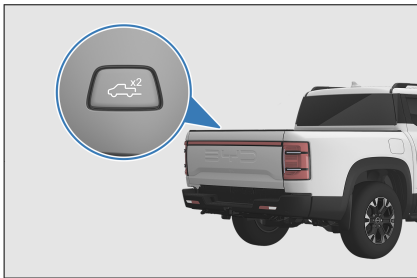

### Opening the tailgate on the infotainment touchscreen

- With the vehicle unlocked, slide down the top status bar on the infotainment screen to display the shortcut page, and tap  to open the tailgate.

### Closing the tailgate manually

- When the tailgate is open and still, push it upward, and it will be closed after fully locking.

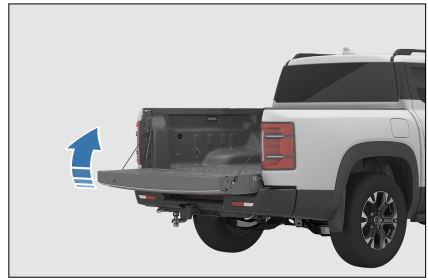

### WARNING

- In order to prevent serious injury and even death, make sure to observe the following precautions when operating the tailgate:
  - Make sure the people nearby are safe and alert them of the tailgate's motion.
  - Make sure hands and fingers are clear from the tailgate when it is closing.
  - Make sure the surrounding area is safe when opening or closing the tailgate.
  - Do not allow children to open or close the tailgate, otherwise their fingers and other body parts may be caught, resulting in personal injuries.
  - Make sure the tailgate is properly closed when the vehicle is in motion.
  - Be mindful of windy conditions when opening or closing the tailgate, as it may move suddenly in strong wind.
  - Before loading or unloading the pickup bed, make sure the tailgate is fully open and secure.

## Emergency Tailgate Unlocking from the Inside

An emergency unlock device is arranged under the cover plate of the tailgate. Disassemble the plate and pull the emergency unlock handle, the tailgate can be opened manually.

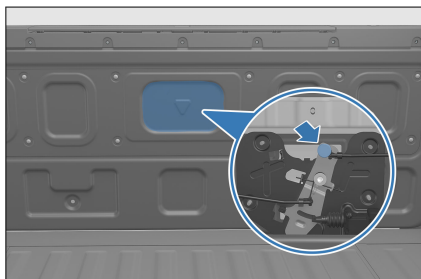

### ! REMINDER

- When the vehicle is powered off, the tailgate can be unlocked from the inside in case of emergency.

## Locking/Unlocking with Central Locking

### Locking or unlocking the vehicle with the central locking

See **P76** in "Driver's Door Switches" in this chapter.

### Locking or unlocking doors automatically

- All doors automatically lock at vehicle speeds above 8 km/h.
- Press the START/STOP button to switch the ignition off. All doors unlock automatically.

### Locking/unlocking all doors concurrently

- With the anti-theft alarm system disarmed, the backlight of the central lock button turns on if the vehicle

is locked and off if the vehicle is unlocked.

- Pressing the central lock button locks all doors so that any attempt to open any door from the outside fails. At this time, pull the interior handle to unlock a door and pull a second time to open it.

### ! REMINDER

- All doors unlock automatically when the vehicle suffers a strong impact, depending on the impact intensity and accident type.

## Emergency Vehicle Locking with Mechanical Key

When the central locking system or the smart key fails, use the mechanical key for emergency locking or unlocking.

### Locking

1. Open all doors other than the driver's door, insert the mechanical key into the door's keyhole and turn the key clockwise about 60°. You can then lock the doors by closing them.



2. After locking other three doors, open the driver's door.
3. Insert the mechanical key into the keyhole, turn it clockwise as far as it can go, return it to the initial position and pull it out. (See **P53** in this Chapter.)



4. Close the driver's door.
5. Check whether all doors are securely locked.

### Unlocking

1. Insert the mechanical key into the keyhole, turn it counterclockwise as far as it can go, return it to the initial position and pull it out.
2. Pull the door handle again to open the driver's door.
3. Pull the interior handle twice to unlock the three other doors.

## Smart Access and Start System

Use the smart key to unlock or lock the vehicle doors and start the vehicle.

### Access

Use the valid smart key to unlock or lock the vehicle doors. (see **P54** and **P55** in this chapter).

### Start-up

With the smart key inside, press the brake pedal and the START/STOP button to start the vehicle. (see **P120** in this chapter.)

### Antenna positions

- ① Interior antenna
- ② Exterior antenna

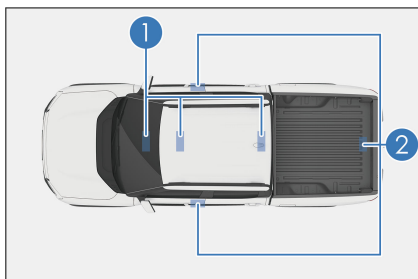

### Active area

The smart access and start functions take effect only when the registered smart key is within the active area.

- ① Active area of the access function: about  $1\text{m} \pm 20\text{cm}$  from the front door handle and the exterior pickup bed switch.
- ② Active area of the start function: inside the cabin.

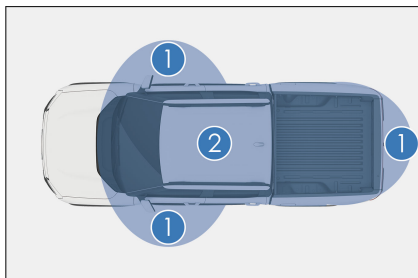

If another smart key is near this vehicle's smart key, unlocking may take longer than usual, which is normal.

### ! REMINDER

In the following situation, smart access and start system may not work normally:

- There is a strong electromagnetic field nearby, such as TV towers, power stations, and broadcasting stations.

## REMINDER

- The smart key is being carried along with a communication device, such as a two-way radio or mobile phone.
  - The smart key is in contact with or covered by a metal object.
  - The door handle is operated too quickly.
  - The smart key is too close to the handle.
  - Another wireless remote control function is being used nearby.
  - When the smart key battery runs out.
  - The smart key is close to high-voltage equipment or equipment that produces noise.
  - The smart key is being carried along with another smart key or radio-wave-emitting device.
  - Even within the active area, the smart key may not work properly in certain locations, for example, on the dashboard, in the glove box, or on the floor.
- If the smart access system is not working properly and it is impossible to enter the vehicle, the mechanical key can be used to lock/unlock the driver's door, or the wireless remote control function can be used to lock/unlock all doors.
  - Pressing the START/STOP button may not enable the start function due to:
    - Smart key failure. If the smart key warning light lights up and the message "Low key battery" is displayed on the instrument cluster, the battery of the key may be exhausted.

- The vehicle is started repeatedly in a short time. Please wait for 10 seconds and start the vehicle again.
- If the smart access and start system cannot work properly due to system failures, bring all smart keys to a BYD authorized dealer or service provider for repair.

## Saving battery power

- The smart key communicates with the vehicle even when the vehicle is not running. Therefore, do not leave the smart key in the vehicle or within two meters from the vehicle.
- Receiving strong electromagnetic waves for a long time drains the battery of the smart key quickly. The smart key must be kept at least one meter away from electrical equipment that generates a magnetic field, such as the following devices:
  - TVs
  - PCs
  - Wireless telephone chargers
  - Electroliers
  - Fluorescent desk lamps

## Child Protection Lock

Child protection locks are designed to prevent children in rear seats from accidentally opening rear doors. Such locks are provided on the sides of the left and right rear doors.

- ① Unlock
- ② Lock

The door cannot be opened from inside the vehicle while the latch is locked. To open this door, use the exterior door handle.



### CAUTION

- Before driving, especially when a child is in the vehicle, ensure that the doors are closed and the child protection lock function is enabled.
- Proper use of seat belts and activation of child protection lock helps prevent the driver and passengers from being thrown out of the vehicle in an accident, and also prevents a door from being opened accidentally.

## Seats

### Seat Precautions

- Adjust the driver's seat so that the pedals, steering wheel, and dashboard controls are within the driver's easy control.
- While driving, the most effective safeguard is to keep the seatback upright, always rest well on the seatback, and adjust the seat belt to the right position.
- Rear seats cannot be folded in with the vehicle running.
- Secure your luggage appropriately to prevent it from skidding or moving.

Luggage in the vehicle should not be higher than seatbacks.

- The head support can only protect your head when it is in the proper position. Remember to adjust it to the proper position if it has been moved.

### WARNING

- Sitting on a folded seatback or on cargo is prohibited. Improper seating position or improperly fastened seat belts can result in personal injuries in case of emergency braking or a collision.
- Do not place any items under the seats. The driver may lose control of the vehicle because items placed there affect the seat locking mechanism, causing the seat to move suddenly.
- When adjusting the seat, do not place your hand under the seat or near its operating parts, to prevent being crushed.
- After adjusting the seatback, lean back to confirm the seatback has been locked. Seatbacks that are not fully locked can cause personal injuries in an accident or during emergency braking.
- Do not put the seatback down while driving or riding in the vehicle. This makes the shoulder strap of the seat belt not properly attached to the body. As a result, occupants could hit the strap in an accident, causing serious injuries to the neck or other parts; or they may slip out of the waist belt, resulting in other serious injuries.
- Do not adjust the driver's seat while the vehicle is in motion, as unpredictable seat movement can

## **WARNING**

cause the loss of vehicle control at this time.

- Do not drive the vehicle until occupants are seated properly.

## **CAUTION**

- When folding seats, make sure no seat belt is damaged.
- Adjust the seat position before fastening seat belts.
- While adjusting a seat, do not let it hit against any passenger or the luggage.

# Adjusting Front Seats

## Adjusting Front Seat with Power

Front seat adjustment includes seatback angle adjustment, seat position adjustment, and lumbar support adjustment\*. The front passenger's seat does not support height adjustment. Choose the following methods according to the actual configuration of your vehicle.

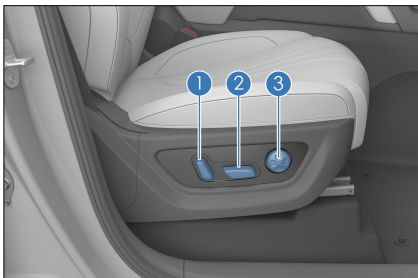

### 1. Seatback angle adjustment switch

- Move this switch forward or backward to adjust the seatback angle.

### 2. Seat position adjustment switch

Seat position adjustment includes forward/backward adjustment and height adjustment\*.

- Toggle the seat position adjustment switch back or forth to move the seat backward or forward.
- Move the front end of the switch up or down to change the seat base angle.
- Move the rear end of the switch up or down to raise or lower the seat.

### 3. Lumbar support adjustment switch\*

The seatback profile can be adjusted to fit the curvature of the occupant's lumbar spine. To allow you and your occupants to sit in the seats in a correct and relaxed manner, the seat should support the occupants' lumbar spine.

- Press the front or rear portion of the switch to increase or decrease the curvature.
- Press the upper or lower portion of the switch to extend the curvature up or down.

## **CAUTION**

- Releasing the switch stops the seat in this position. Do not place anything under the seat as this may prevent the seat from operating.
- Do not move the front seats too far forward to avoid contact with the roof or sun visor.

## Heating and Ventilation Systems\*

The front seats are equipped with seat heating and ventilation systems. To turn on or off the systems, go to the infotainment touchscreen →  →

**Vehicle** → **Seats** → **Vent Heating**, or go to the A/C operation interface.

### Heating adjustment

- Seat heating: On the infotainment touchscreen, tap the heated seat controls to select a heating level: 1 or 2.
- The initial state of the heating indicator is off.
- Tap to select the operation mode among level 1, level 2, and OFF.
- Tap OFF to stop heating.

### Ventilation adjustment

- Seat ventilation: Control the operation mode of the ventilation fan by using the seat ventilation switch. Seat ventilation has two modes.
- The initial state of the heating indicator is off.
- Tap to select the operation mode among level 1, level 2, and OFF.
- Tap OFF to stop ventilation.

### Ventilation and heating cannot be activated at the same time.

- Press the ventilation switch to make the ventilator work; if the heating switch is then pressed, the ventilator will stop and the heater will start to work.
- Press the heating switch to make the heater work; if the ventilation switch is then pressed, the heater will stop and the ventilator will start to work.

## Folding Rear Seats

- Flipping and lowering the seatback
  - Pull the cord to straighten the seatback.

- Push the seatback forward/backward to fold it. You can fold the seatback forward until the back touches the cushion.

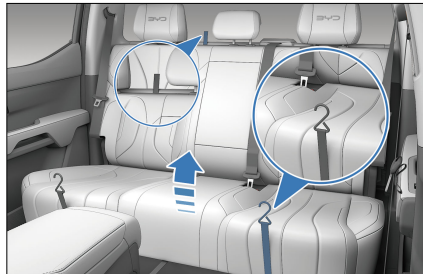

- Fold the cushion
  - Pull up the strap on the seat cushion.
- Lift up and turn over the cushion until it contacts the seatback. Attach the hooks on the pull straps on both sides of the cushion to the inner head support post.

### CAUTION

- Pay attention to the followings when folding the seats:
  - Do not put the seatback down with the vehicle running.
  - Do not fold the seats with the vehicle running.
  - Make sure the second-row seats are fully locked before driving.
  - After the rear seatback is put down, never place luggage on the back.
  - Unlock all seat belt buckles and latches before folding the seat.
  - After the seat is folded, the lower area is the maintenance area which is forbidden to be stepped and put objects on.

# Head Supports

## Adjusting Head Supports

- Lifting a head support
  - Lift the head support to a proper position, and release it after hearing a locking sound.
- Lowering a head support
  - Press and hold the head support adjustment button, lower the head support to a proper position, and then release the button after hearing a locking sound.

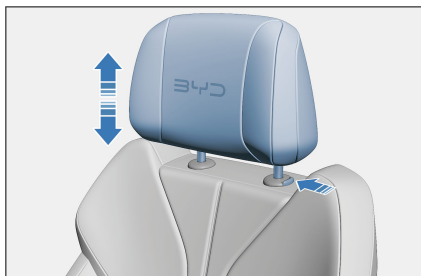

- Removing a head support
  - Press and hold the head support adjustment button, remove the head support and release the button.
- Installing a head support

- Insert the head support levers into the bushing with the grooves facing forward. Press the head support adjustment button, push down the head support to a proper position, and then release the button.

### ! REMINDER

- Head supports protect vehicle occupants from head and neck injuries. Adjust the head support so that its center aligns with the back of your head for maximum protection. Adjust the head support to the proper position based on your actual height.
- When adjusting head support height, align the occupant's ear tip line with the center line of the head support.
- After adjusting the head support, ensure that it is locked into position.
- Do not drive the vehicle without head supports.
- Do not attach any objects to the head support levers.

# Steering Wheel

## Steering Wheel Switches

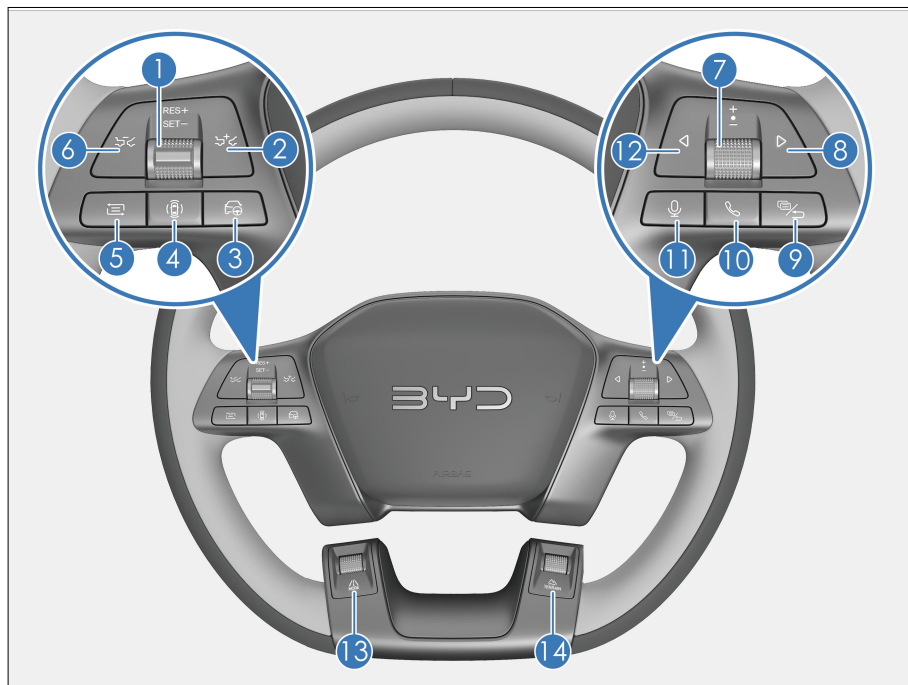

- |   |                     |    |                         |
|---|---------------------|----|-------------------------|
| 1 | + /Reset or - /Set  | 8  | Right                   |
| 2 | Distance +          | 9  | Instrument cluster/Back |
| 3 | Cruise switch       | 10 | Call                    |
| 4 | Panoramic view      | 11 | Speech recognition      |
| 5 | Driving information | 12 | Left                    |
| 6 | Distance -          | 13 | Mode                    |
| 7 | Scroll button       | 14 | Terrain                 |

The audio control switch is operational when the ignition is switched on.

### Left-hand buttons

Rocker switch

- Reset+/: Activates the cruise control system and uses the previous system settings.
- Set - /: Sets the current speed to the target cruise speed.

#### Distance -

- Decreases the time-based following distance from the vehicle ahead by one level each time it is pressed with ACC active. A total of four levels are available.

#### Distance +

- Increases the time-based following distance from the vehicle ahead by one level each time it is pressed with ACC active. A total of four levels are available.

#### Cruise switch

- Press this button to turn the cruise control system on or off.

#### REMINDER

- For instructions on using cruise control, see **P134**.

#### Panoramic view

- Press this button to enable or disable the panoramic view system.

#### Driving information

- Press to cycle through the driving information interfaces, and press and hold to clear the relevant driving information.

#### Right-hand buttons

##### Scroll button

- Roll the button upward to increase the volume. The button is non-operational when the volume reaches the highest.
- Roll the button downward to decrease the volume. The button is non-operational when the volume reaches the lowest.
- Press down the button to mute.

##### Left/Right button

- When the infotainment system is in radio mode:

- Press the ◀ button to select previous radio station.
- Press the ▶ button to select next radio station.

- In USB/Bluetooth music/third-party music APP and other modes:

- Press the ◀ button to play the previous track (track number -1).
- Press the ◀ button to select a record upward on the Bluetooth call record or phonebook screen.
- Press the ▶ button to play the next track (track number +1).
- Press the ▶ button to select a record downward on the Bluetooth call record or phonebook screen.

#### Call

- Press this button to make or receive a call. The audio system is muted at the same time.
- When a Bluetooth-unrelated screen is currently displayed, press this button to switch to the phone selection screen if Bluetooth is disconnected, or to the Dial screen if Bluetooth is connected.
- After entering a phone number on the Dial screen or selecting a record on the Call Log or Contacts screen, press this button to dial the number.
- When Bluetooth is connected, but no phone number is entered on the Dial screen, press this button to switch to the Call Log screen. Press this button again to call the first dialed number on the call history.

#### Speech recognition



- Press this button for the infotainment touchscreen to switch to the voice recognition screen.
- Press this button again to re-enter a voice command.

#### Instrument cluster/Back

- When not on the Bluetooth call screen, press this button to select the lower menu items.
- When on the Bluetooth call screen, press this button to end the call.

#### Horn

- Press the horn button area to honk the horn, and release to stop honking.

#### CAUTION

- Avoid pressing honking for too long, as the horn may be damaged.

#### REMINDER

- Observe the traffic laws and use the horn properly.

#### Lower scroll button

##### Mode

- Turn the scroll button to switch between ECO/NORMAL/SPORT modes.

##### Terrain

- Turn the scroll button to switch between snow/sand/mud/mount modes.

## Adjusting the Steering Wheel

### Adjusting the Steering Wheel Manually\*

To adjust the steering wheel position, hold it and operate as follows:

- Push down the steering wheel adjustment handle, adjust the steering wheel to the desired angle, and then return the handle to the locking position.

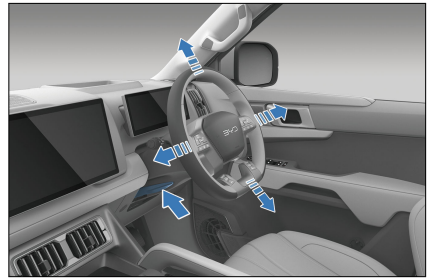

#### REMINDER

- Never adjust the steering wheel while driving, as this is under risk of impaired vehicle control, which can lead to accidents.
- After adjusting the steering wheel, move it up and down to verify that it is securely locked.

### Steering Assist Mode Settings

- The level of steering assistance can be adjusted to individual preferences.
- To set the steering mode, go to the infotainment touchscreen →  → **Vehicle** → **Intelligent Chassis** → **Steering mode**, and select Comfort or Sport.





## ! REMINDER

- Setting the steering mode to sport mode is suggested if the steering wheel feels light when the vehicle is running at a high speed. Steering assist mode settings can only be changed in ECO, NORMAL, and SPORT modes with LKS off, no obvious turning action and a vehicle speed lower than 80 km/h.

# Wipers



## Wiper Switch

### Front Windshield Wipers and Washer

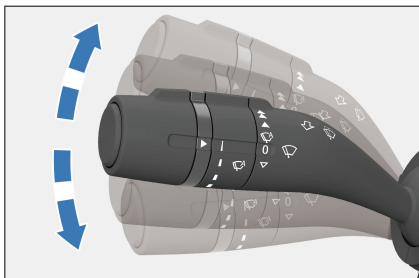

- The lever is used to control the windshield wipers and washer. It has five modes:
  -  : Fast
  -  : Slow
  -  : Auto wipers/Intermittent
  -  : Stop
  -  : Point-wiping



- Push up or pull down the lever to select a mode.

- In slow and fast modes, the wiper operates continuously.
- Pulling down the lever from the  position activates the point-wiping mode . The wipers wipe at a low speed until you release the lever.

### Auto wipers/Intermittent

- The rain sensor automatically controls the operation mode of wipers based on the rainfall, and it is located in front of the interior rearview mirror on the front windshield inside the vehicle.
- To use the auto wiper function, turn the wiper switch to the automatic mode and enable **Auto Wiper** on the infotainment touchscreen →  → **Vehicle** → **Comfortable Use**.
- To use the intermittent wiper function, turn the wiper switch to the automatic mode, and disable **Auto Wiper** on the infotainment touchscreen →  → **Vehicle** → **Comfortable Use**.
- The automatic wiper function has four sensitivity levels. The higher the lever, the higher the sensitivity. When using the automatic wiper function, change the sensitivity by adjusting the toggle based on real-time rain conditions. If the wiper reacts to rain too quickly, reduce the sensitivity; if the wiper reacts to rain too slowly, increase the sensitivity.

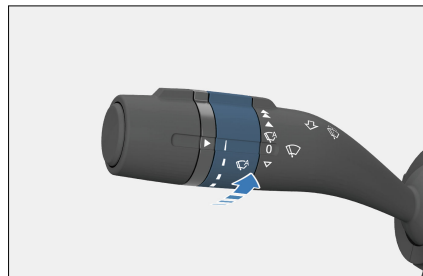



### WARNING

- With the ignition on and the wiper handle at  , touching the glass on the top of the sensor by hand or wiping it with a cloth can cause the wiper to work and thus lead to an accident.
- Turn off the automatic mode of wiper during the vehicle washing process, in dry seasons or in rainless weather to prevent inadvertent wiper operation.

### CAUTION

- When the wiper stops midway for snow accumulation and other reasons, please turn it off, park the vehicle in a safe place, and remove the snow and other debris, so that the wiper can work properly.
- The sensor may occasionally fail to properly identify snowflakes on it as they have various shapes, which could lead to wiper malfunction. After the snow has melted, it may result in automatic wiping of the wiper.

### REMINDER

- With the wiper handle located in  , the wiper will perform a wiping action whenever the wiping sensitivity is increased by one shift; when the wiper is turned from OFF to  , the wiper will perform a wiping action.

#### Front windshield washer

Pull up (toward the steering wheel) the wiper switch for the system to only sprays water without wiping if pull-up time

is short (within 0.5 seconds), or sprays water continuously for 10 seconds and wipe it at a low speed if pull-up time is long. Release the wiper switch for the wiper to automatically wipe two times and then return to its original position.



### CAUTION

- Check and clean the wiper blades at regular intervals.
- Do not start the wipers while rain is starting, as the windshield cannot be cleaned and rainwater mixed with sand and dust may instantly blur your view, affecting driving safety.
- Use cleaning agent for glass. The use of water, or another type of detergent, may damage the washer motor.

## Replacing Wiper Blades

### Replacing Wiper Blades

- Inspect front wiper blades for cracks or partial hardening at least every six months. If they are noted, replace wiper blades. Otherwise, the windshield will streak or will be left unclean after wiping.
- When the vehicle is powered on, tap  → **Service** → **Overhaul** → **Front Wiper Check** to enable or disable the

front wiper check function. When the corresponding wiper check function is enabled, the wipers rotate out for easy maintenance and replacement.

### Replacing front wiper

1. Pull up the wiper arm at the driver side, and then pull up the other at the passenger side.
2. Press the wiper lock button ①.
3. Hold the wiper blade and pull it out along the indicated direction ②;
4. When installing a new wiper blade, follow the reverse procedure.

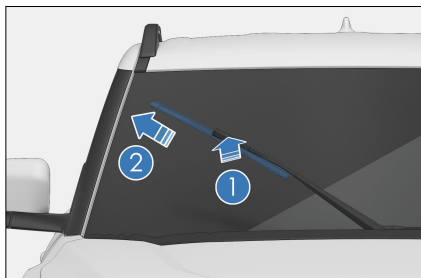

#### WARNING

- Do not open the hood when the wiper arms are pulled up, as this may damage the hood and wiper arms.
  - Handle wiper blades with care. Do not push the wiper arm to let the wiper blade straightly strike onto the windshield.
  - Do not bend the wiper blade, and do not obstruct the wiper blade when the wiper is in operation.
- For wiper blades maintenance, see **P206**.

## Rearview Mirrors

### Interior Rearview Mirror

#### Automatic Anti-glare Interior Rearview Mirror

- The automatic anti-glare interior rearview mirror is equipped with electronic anti-glare function, which automatically adjusts the lens color of the mirror according to the surroundings to reduce the interference of rear glare on the driver's field of vision.
- Move the interior rearview mirror up or down, left or right to a suitable position.

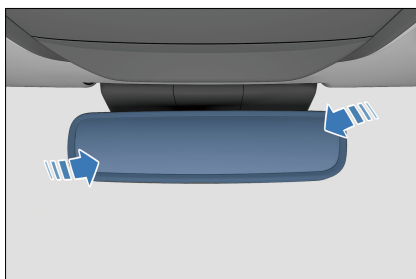

#### WARNING

- Do not hang heavy objects on the interior rearview mirror, or shake or drag it with force.
- When manually adjusting the interior rearview mirror, do not forcibly adjust the stuck mirror to avoid the mirror falling off.
- Adjusting the interior rearview mirror before driving. Do not adjust the rearview mirror while driving. This may distract your attention, causing accidents.

## Side Mirrors

### Side Mirror Adjustment Buttons

#### Side mirror selection buttons

 Left side mirror button

 Right side mirror button



#### Side mirror adjustment buttons

Press this button to adjust the side mirror lens to a right position.

#### Side mirror folding control

Press this button to fold or expand side mirrors.

### Folding Side Mirrors

#### Folding side mirrors manually

- Push the outer edge of a side mirror to rotate it around the folding axis to the locked position.

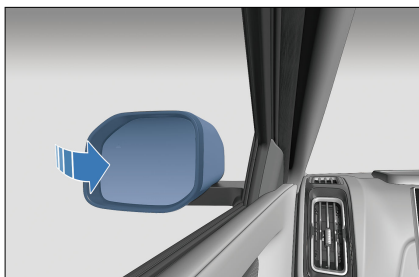

### Folding side mirrors with power

- Press the  button to fold the side mirrors with power. Press the button again to unfold the mirrors.
- Both side mirrors fold automatically when the anti-theft alarm system is armed, and extend automatically when the system is disarmed.



#### REMINDER

- For the introduction of side mirror buttons, refer to **P71**.

### Side Mirror Defrosters

Tap this button, and the heating panel in side mirrors will quickly clear the side mirrors.

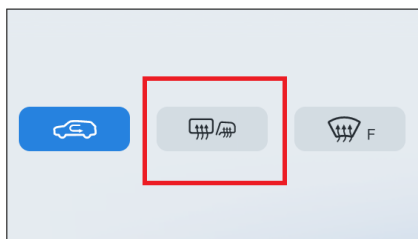

#### REMINDER

- Adjusting side mirrors before driving. Do not adjust the side mirrors while driving. This may

## ! REMINDER

distract your attention, causing accidents.

- Using the side mirror electric heating defrosting function for a long time may cause the mirror to wear out faster. Turn off the defrost button when it is not needed.

# Switches

## Light Switches

Set the light switch to 0 to turn off all lights except for daytime running lights.



### Auto lights

Set the light switch to . The BCM captures the brightness data from the light intensity sensor to automatically turn the position lights and low beam on or off.

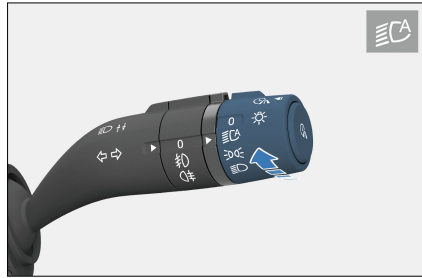

## ! REMINDER

- The light intensity sensor is located on the top of the windshield. Do not block the sensor or let anything splash on it.

### Position lights

Set the light switch to  to turn on lights such as position lights and license plate light.





### Low beam

Set the light switch to  to turn on the low beam.



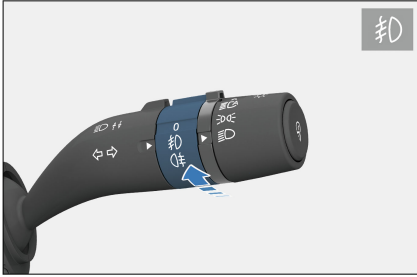

**Front fog light**

Set the light switch to  and rotate the fog light dial to  to turn on front fog light.



**Rear fog lights**

Set the light switch to  and rotate the fog light dial to  to turn on rear fog light.



**High beam**

Set the light switch to  and push the light switch lever down (away from the steering wheel) to turn on the high beam.



**Overtaking light**

Pull up the lever (toward the steering wheel) to turn on the overtaking light. Release the lever for the light switch to automatically reset. The overtaking light turns off.



**Turn signals**

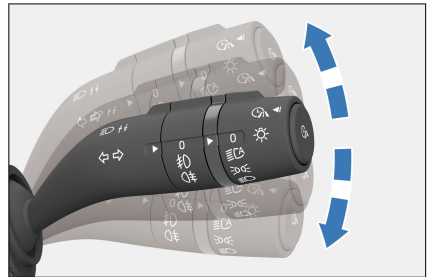

- Push up the lever to signal right turn. The right turn signal and its indicator on the instrument cluster flash.
- Pull down the lever to signal left turn. The left turn signal and its indicator on the instrument cluster flash.



- Once turned on, turn signals continue flashing even after the lever is released. They will turn off after the turn is complete. Depending on the driver's habit, the turn signal will reset after the vehicle turns around under some extreme conditions.

**Auto light off**



- Conditions to activate the auto light off function: To activate this function, set





the light switch to  or  and switch off the vehicle power.

- When the auto light off function is activated, the headlights, position lights, front fog lights, rear fog lights, and high beams turn off in 10 seconds if the driver's door is closed.
- When the auto light off function is activated, the headlights, position lights, front fog lights, rear fog lights, and high beams turn off in 10 minutes if the driver's door is open.
- After the lights turn off automatically, if the light status changes, these lights come on in the new status. If the conditions to activate the auto light off function are still met, the function is activated again.
- Disabling of the auto light off function: When the vehicle is powered on, the auto light off function is disabled, and the light switch can be operated normally.
- If the auto light off function has turned off the lights and the anti-theft alarm system has been armed, disarming the alarm system makes the lights come on again automatically. If the driver's door remains closed, the lights go off again after 10 seconds. But if any door is open, it turns off the light in 10 minutes.

### Lighting delay

- Headlights After Exit:
  - Set the time for "Headlights After Exit" on the infotainment touchscreen →  → **Vehicle** →

**Light** (default: 10 seconds). With the light adjustment switch turned to ", " " or " ", when you power off the vehicle, lock four doors and attempt to leave the vehicle, the corresponding lights will continue to light up for 10 seconds (or the set time) to provide coming-home lighting.

- Headlights Before Entry:
  - Set the time for "Headlights Before Enter" on the infotainment touchscreen →  → **Vehicle** → **Light** (default: 10 seconds). With the light adjustment switch turned to ", " " or " ", when you unlock the vehicle and attempt to approach it, the corresponding lights will light up for 10 seconds (or the set time) to provide the leaving-home lighting.

### Adjusting Headlight Height

When the low beam is on, on the infotainment touchscreen, tap  → **Vehicle** → **Light** → **Headlights Height** to adjust the vertical beam angle of the headlights.

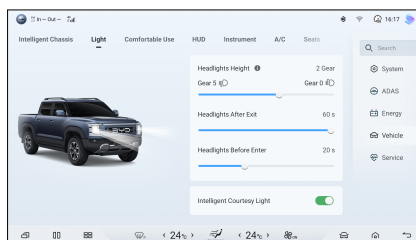

### Loading Conditions

### Recommended Lighting Level

One person in the driver seat

0-2

The driver, plus one passenger in the front seat



Loading Conditions	Recommended Lighting Level
All the seats occupied	0-2
All the seats occupied, plus a fully loaded pickup bed (evenly distributed)	1-3
Driver, plus a fully loaded pickup bed (evenly distributed)	1-3

- Vehicle loading conditions may differ. Adjust accordingly.

## Driver's Door Switches

### Power Window Switches

- The switch on each door can be used to control the window.
- The ignition has to be switched on.
- The window control switch at the driver's side contains four buttons to roll up or down windows on four doors, respectively.
  - Press a switch to roll the window down.
  - Pull a switch to roll the window up.
- While using the switch, release it to stop window halfway.



- Driver's side power window: Press all the way down and release the switch to open the window. Lift all the way up and release the switch to close the

window. Press the switch again to halt the current action.

### Anti-pinch function

- If someone or an object is caught by the window when it is rolling up, the window stops and rolls down automatically.

### Initialization of anti-pinch function

- Pull the switch to close the window, then release immediately. Repeat the first step and hold the switch for at least 400 ms.

#### **WARNING**

Please follow the precautions below to prevent serious injury or death from window closing:

- Before operating the power windows, ensure that all passengers do not have any body parts that can be caught in the window.
- Do not allow a child to operate the power windows.

#### **CAUTION**

- Excessively frequent activation of the anti-pinch function can activate the regulator motor's overheat protection.
- Never try to deliberately activate the anti-pinch function.

## CAUTION

- The anti-pinch function may not work if an object is jammed into the window when it is almost completely closed.
- Contacting a BYD authorized dealer or service provider for maintenance is recommended if the windows' automatic closing function or anti-pinch function is not working normally.
- In the low temperature, if the space between the glass and frame of window is frozen or covered by ice and snow, resulting in failure of the normal operation of windows, it is forbidden to repeat operating windows to avoid damage to the glass lifting module or other parts. After the hot air of air conditioner warms the vehicle and thaws the glass, the normal lifting can be operated.

## Window Lock Button

- Press the window lock button. Only the switches on the driver's side can be used to open/close four windows; the window switch on the front passenger's side can be used to open/close its window; the window switches on the rear row are deactivated.
- Press the switch a second time. The indicator goes out, and all the window switches work normally.



## Central Locking

The driver's door is equipped with power door lock switches. Both switches can lock or unlock all doors.

### ① Unlock

Press the central unlock button. All doors are unlocked and the red lock indicator turns off.

### ② Lock

Press the central lock button. All doors are locked and the red lock indicator lights up.

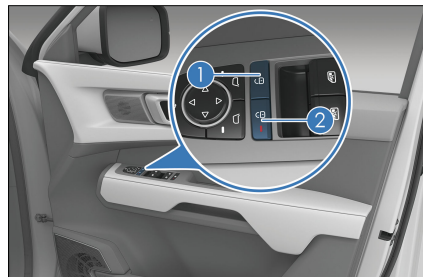

## Window Control Switch on Passenger Side

- When the ignition is on, use the left front and rear door window switches to operate the respective windows.

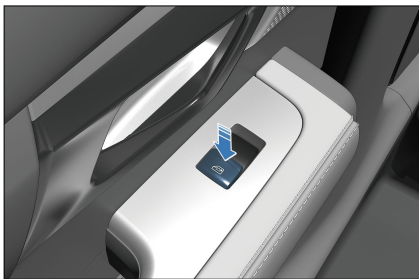

## Odometer Switch

- Press the odometer switch to switch between "Total Mileage" - "Mileage 1" - "Mileage 2" - "Total Mileage" - "HEV Mileage" - "EV Mileage". The according status is displayed on the instrument cluster.
- Press and hold "Mileage 1" and "Mileage 2" to clear the mileage information.



## Hazard Warning Light Switch

- When the  button is pressed, all turn signals and turn signal indicators on the instrument cluster start flashing. They all stop flashing when the  button is pressed again.

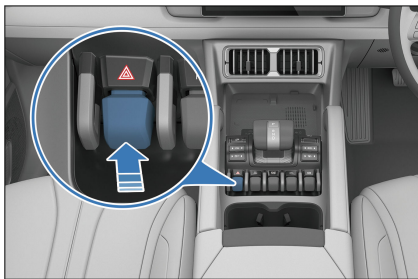

## Interior Light Switch

### Front Interior Lights Switches

- Press the interior light buttons to turn on left/right interior lights. Press again to turn them off.

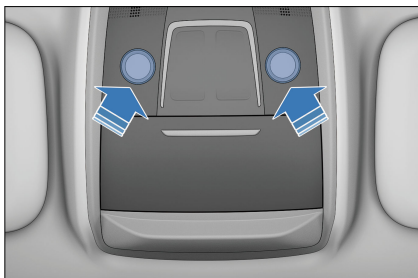

- With the ignition on, if DOOR option is selected and any door is open, interior lighting switches between high and low brightness with touches on the light switch.
- With the ignition off and DOOR option selected, interior lights will go off after the door have remained open for a period of time. If there are other operations during this period, the timer will be restarted.
- To turn on or off the "DOOR" gear, slide down the top status bar on the infotainment screen to display the shortcut page.

## Rear Side Interior Light Switches

- With the vehicle in any power mode, press this button to turn on the left/right interior light. Press again to turn them off.

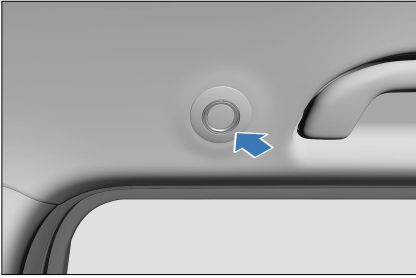

## Pickup Bed Light Switch

- Interior switch: In "P" gear, slide down the top status bar on the infotainment screen to display the shortcut page to turn on or off the pickup bed lights.
- Exterior switch: In "P" gear, press the button on the left wall of the pickup bed to turn on or off the lights.

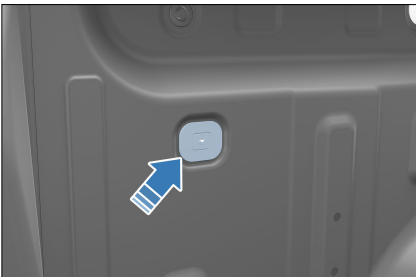

# 04

## USING AND DRIVING

Charging/Discharging.....	80
Batteries.....	98
Usage Precautions.....	101
Starting and Driving.....	120
Driver Assistance.....	134

# Charging/ Discharging

## Charging Instructions

### Charging Safety Warnings

- The charging connector uses high-voltage current. Minors are prohibited to charge the vehicle or touch the charging equipment. Keep them away from the vehicle during charging.
- Charging may affect medical or implanted electronic devices. Consult the device manufacturer before charging.
- Charge the vehicle in a safe environment, and avoid charging in damp areas, or areas with fire or heat sources.
  - Protect the charging equipment against water contact on rainy days.
- Before charging, ensure that there is no water or foreign material in the charging ports of the vehicle, power supply equipment, and charging equipment, and no damage or bad effect caused by metal terminal rust or corrosion. In the event of any of the situations above, do not charge.
- Use charging equipment that complies with local standards.
  - To avoid charging failure or fire, do not modify, disassemble, or repair the charging equipment and related ports. Contact a BYD authorized dealer or service provider for handling if there is a fault.
  - Ensure the quality of charging equipment.
- To reduce the risk of electric shock and personal injury, never operate the

equipment with wet hands or touch the exposed metal of the charge port or charge base.

- Never drop the equipment or move it by pulling it directly by the cable. Take caution when moving and using the equipment.
- If anything abnormal is found in the vehicle or charging equipment during charging, stop immediately and contact a BYD authorized dealer or service provider.
- Do not carry out maintenance work during charging.
- Always observe the following charging precautions to prevent damage to the vehicle:
  - Do not touch the metal connection of the charge port, charging connector, or plug.
  - Do not shake the charging connector.
  - Do not charge or touch the vehicle in a thunderstorm. Lightning strikes may cause damage to the charging equipment or personal injuries.
- Do not open the hood for maintenance while charging.
- After charging, do not disconnect the charging equipment with wet hands or while standing on any wet surface.
- Always unplug the charging and discharging equipment and close the charge port door before driving.

### Compatibility of vehicle and charging infrastructure\*

- The signs are located on the vehicle's charging socket, components of the local charging infrastructure (charging stations and sockets) and on the charging cable.

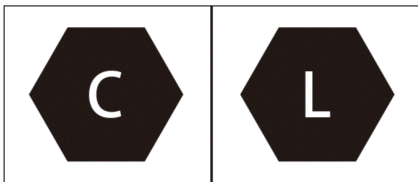

## Charging Precautions

- When the State of Charge(SOC) bar on the instrument cluster turns red, the high-voltage battery is about to be exhausted. Please charge it immediately.
  - Although AC and DC charging can be carried out in any power mode, it is recommended to power off the vehicle before charging to ensure safety. The vehicle cannot be driven during charging.
  - To prevent failure of the charge port door, do not open and close it repeatedly. The recommended time interval for opening and closing the port door is at least one second.
  - If power supply resumes after short-time outage of the external power grid, BYD charging equipment will restart charging automatically and no re-connection of the charging equipment is required.
  - If the charge port door and charging connector are frozen due to weather or other reasons, do not forcibly open the charge port door or pull out the charging connector.
  - To prevent damage to the charging equipment (precautions for charging equipment):
    - Before starting the vehicle, ensure that the charging equipment is disconnected. The vehicle is ready to drive even if the charging connector is incorrectly inserted, which may damage the charging equipment and the vehicle.
  - Do not close the charge port door when the port cap is open.
  - Do not pull or twist the charging cable with force.
  - Prevent any mechanical impact, such as fall and collide, on the charging equipment.
  - Do not store or use the charging equipment at a temperature above 50°C.
  - Do not place the charging equipment near heaters or other heat sources.
- Precautions before charging:
- With the charge port unlocked, open the port, hold the charging connector, align the connector with the charge port and push it in, making sure that they are properly connected.
- Precautions during charging:
- The A/C can be used as normal while the vehicle is being charged. However, the charging power may be reduced.
  - It is recommended to park the vehicle in a ventilated area during charging. Do not block the front of the vehicle within half a meter.
  - It is normal that when the battery is heating up and working, the charging power displayed on the instrument cluster may fluctuate temporarily.
  - The estimated remaining time to full charge is displayed on the instrument cluster. It is normal that it may vary slightly, depending on the temperatures, SOC and charging facilities.
  - Battery cooling may start, and the compressor, fan and other

components work when necessary. It is normal that there will be some noise under the hood.

- Before charging is complete, battery equalization is activated for longer battery life and thus the charging time may be longer.
- Precautions after charging:
  - Stop charging first and make sure the charge port is unlocked.
  - Pull out the charging connector.
  - Do not force the charging connector out while the charge port is locked, otherwise the charge port may be damaged.
  - After unplugging the charging connector, make sure that the charge port's cap and door are closed, otherwise water or foreign materials may enter the port and affect its normal use.
- Battery temperatures that are too low or too high compromise vehicle charging performance.
- In the case of low-temperature charging, the battery thermal management can improve the low-temperature charging capacity of the battery, but the charging time is prolonged and the heating power consumption is increased. These are normal phenomena.

- When the temperature is low, it is recommended to charge the vehicle in a heated place indoors.
- When the temperature is high, it is recommended to charge the vehicle in a cool, ventilated place.
- Recommendations for improving the driving experience:
  - It is recommended to charge the vehicle immediately after using it, for better charging performance.
- Mode 2 charging means charging with an AC charging connector. Use a dedicated AC line and power outlet that meets local standards. A dedicated line protects the line from tripping due to line breakage or high-power charging of the high-voltage battery. Using a non-dedicated line may affect the proper operation of other devices on the shared line.
- When the vehicle is not used for an extended period, it is recommended to charge it once a month at least.
- Suggestions for using mode 2 charging cable: To stop charging, remove the charging connector and then the power plug.

### General Charging Troubleshooting

Fault	Possible Cause	Solution
Charger is connected and charge starts, but battery cannot be charged.	Charging card in arrears or faulty charging pile.	Consult card balance or contact charging station staff.
	The AC charging connector is not properly plugged in.	Ensure the charger switch has come up. Check cable length and connection correctness.
	Low-voltage battery over-discharges.	Connect the vehicle to another 12V low-voltage battery to charge its own low-voltage battery after the vehicle is powered on.



Fault	Possible Cause	Solution
	The local standard grounded socket has no power supply.	Check whether the power supply is under overload protection and use other sockets.
	The vehicle or AC charging connector fails.	Stop charging and contact a BYD authorized dealer or service provider if power system fault warning light or charging system fault message is found on the instrument cluster.
	The high-voltage battery temperature is too low or too high.	Warm up or cool down the high-voltage battery. Keep the vehicle in an environment with appropriate temperature and charge it when the temperature becomes normal.
	The high-voltage battery has been fully charged.	When the high-voltage battery is fully charged, the charging will stop automatically.
Charging stops midway.	The charging cable is not connected properly.	Verify that whether the charging connection cable is loosely connected.
	Power outage	After the power is restored in a period of time, the charging connection should be connected again to start charging.
	The high-voltage battery temperature is too high.	In this case, charging stops automatically. Charge the vehicle when the battery temperature returns to a normal level.
	The vehicle or charging pile fails.	If there is any fault prompt for the charging pile or the vehicle, it is recommended to contact a BYD authorized dealer or service provider.

## Charging

- Check Before Charging:
  - Ensure that power supply equipment, charging connector, charge port, and charging connection device are free of defects, such as cable wear, rusted ports, cracked casings, or foreign objects in the ports.
  - When the metal terminals of the charging connector, charge port, power plug, or power socket are loose or damaged by rust, corrosion, or ablation.
    - When the charging connector, port, power plug, or socket is visibly stained or damp, wipe them with a dry and clean cloth to ensure that the connection is dry and clean.
    - In case of any situation above, do not perform the charging operation, or it may cause a short circuit or electric shock, resulting in personal injury.
    - Protect the charging equipment against water contact on rainy days.

### Using Mode 2 Charging Cable

#### 1. Equipment descriptions

- This mode 2 charging cable includes a power plug (complying with local standards), an AC charging connector, a connector protective cover, a charging cable, and a control box. The plug is connected to a standard household power socket, and the charging connector to the vehicle's AC charge port.
- A household socket meeting local standards must be used in order to avoid line damage or tripping due to high-power charging, which may effect the normal use of other devices.
- Connect the vehicle to a socket that meets local standards to charge the vehicle.
- Charging time: Refer to the charging time message on the instrument cluster.

 **WARNING**

- See "Charging Instructions" for charging safety warnings.
- The highest working temperature allowed for the charging equipment is 50°C. Store it in a cool and dry place when it is not in use.
- When charging, do not place the equipment on the pickup bed, under the front of the vehicle, or near the tires.
- When using the equipment, prevent it from getting rolled over by the vehicle, dropped, or trampled on.
- It is strictly prohibited to modify, disassemble, or repair the charging equipment and its ports. If a fault occurs, it is recommended to contact a BYD authorized dealer or service provider.

 **WARNING**

- It is not recommended to use any additional wire or adapter/connector. If an additional adapter is required, contact a BYD authorized dealer or service provider to choose a suitable cable diameter ( $\geq 1.5 \text{ mm}^2$ ) and the adapter/connector parameters must meet requirements.
- Never use the charging equipment if the household power strip cable becomes soft, if the charging connector cable is worn out, if the insulation layer is cracked, or in case of any other damage.
- Never use the equipment when the charging connector, power plug, or power strip is disconnected or broken, or if there is any sign of surface damage.
- To prevent failure of the charge port door, do not open and close it repeatedly. The recommended time interval for opening and closing the port door is at least one second.

 **CAUTION**

- The charging cable must not be placed in a spiral during charging, as this will affect heat dissipation.
- See the charging instructions for specific charging precautions.

 **REMINDER**

- It is recommended to contact a BYD authorized dealer or service provider or local electrician to select an appropriate power

## ! REMINDER

supply according to requirements of the charging equipment.

- Charging equipment grounding instructions: The equipment must be properly grounded. In the event of failure of or damage to the equipment, the ground cable provides a minimum impedance to circuit discharge and thereby reducing the risk of electric shock. The equipment comes with a ground cable connecting its ground point with that of the power plug, which must match a properly installed and well-grounded power supply socket.
- The power plug must match a properly installed and well-grounded power supply socket which meets the requirements of safety standards.
- When using mode 2 charging cable, activate the anti-theft function of the vehicle.

## 2. Charging

- Unlock the vehicle and open the charge port door.
- Open the charge port door:
  - With the vehicle unlocked, press the charge port door on the right side of the vehicle to open it manually.



- Open the charge port cap, and make sure that no obstacles exist between the head of the charging connector and the end of the charging socket.



## ! REMINDER

- Do not open the charge port door forcibly when it is locked.
  - If the charge port door is frozen due to weather or other reasons, it is suggested to warm it with hot water and then open the port, do not force it open.
- Connect the power supply terminal:
    - Plug the mode 2 charging connector into a household socket and its red power indicator on the control box comes on and stays solid.
  - Connect to the vehicle port:
    - Plug the charging connector into the port and make sure it is tight.
    - After the charging connector is inserted, the charging connection indicator lights up on the instrument cluster. The charging indicator of mode 2 charging equipment flashes green.

### REMINDER

- Do not force the charging connector in with the immobilizer system activated.
- In the charging process, charging parameters and the charging sign are displayed on the instrument cluster.
- At this point, you can schedule charging in the infotainment touchscreen →  → **Energy** → **Charging and Discharging**. See **P89** in this chapter for the configuration process.

### REMINDER

- During charging, the estimated remaining time to full charge is displayed on the instrument cluster or infotainment touchscreen. It is normal that it may vary slightly, depending on the temperatures, SOC and charging facilities.
- Scheduled charging cannot be used when the battery is too low.

## 3. Stopping charging

- End the charging:
  - The charging automatically ends when the vehicle is fully charged.
  - To end the charging early, proceed to the next step.
- Unplug the charging connector:
  - If the immobilizer of the electrical lock is deactivated on the infotainment touchscreen, you can pull out the charging connector directly.
  - If the immobilizer is activated on the infotainment touchscreen, press the unlock button on the key or press

the door handle microswitch with the key nearby, and then pull out the charging connector.

### REMINDER

- To unlock the vehicle, press the unlock button on the key (when charging the vehicle with ignition switched off) or press the microswitch on the door handle (when the key is nearby).
- When the immobilizer is enabled, unlock the vehicle to release the immobilizer of the charge port before pulling out the charging connector. The connector has to be pulled out within 30 seconds, or the port will re-lock.
- You can set the immobilizer system in the infotainment touchscreen →  → **Energy** → **Charging and Discharging**, as detailed in **P95** in this chapter.
- If the charging connector cannot be removed after unlocking, try a few more unlocking attempts. If that does not work, try emergency unlocking. For the operating procedure, see **P97** in "Charging Port Immobilizer System".
- If you cannot pull the charging connector out directly with the charge port's immobilizer system deactivated, try to unlock the vehicle and pull it again.
- Disconnect the power plug.
- Close the charge port cap and the port door.
- Store the charging equipment properly.

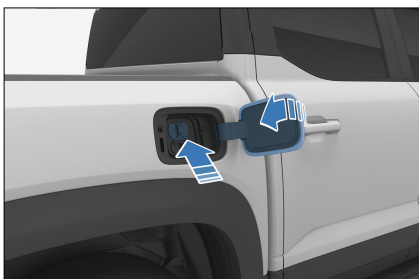

### ! REMINDER

- Do not close the charge port door when the port cap is fully open.

## Using AC Charging Piles

### 1. Equipment

- Single-phase AC charging box\*
  - Use a standard-compliant charging box. For how to use the charging equipment, refer to its user manual and follow the operating steps.
  - The single-phase AC charging box consists of a charging box, a charging connector, and a connecting cable. For information on circuit breaker and emergency stop switch, see the charging box user manual.
- Single-phase AC charging pile
  - Charge the vehicle using a single-phase AC charging pile in a public place. Since some charging piles are not equipped with charging connectors, AC charging connectors need to be prepared.
- AC charging connector\*
  - It includes a power plug (complying with local standards), a charging connector, a connector protective cover, and a charging cable. The plug is connected to the power outlet, and the charging connector to the vehicle's charge port.

### ! REMINDER

- When using an AC charging connector, pay attention to the identification of power plug and charging connector in order to avoid reverse connection.
- Three-Phase AC Charging Pile\*
  - Charge the vehicle using an AC charging pile in a public place.
  - Using a BYD three-phase AC charging pile is also allowed. For how to use the charging equipment, refer to its user manual and follow the operating steps.
  - Charging time: Refer to the charging time message on the instrument cluster.

### 2. Charging

- Unlock the vehicle and open the charge port door:
  - Open the charging port hatch by following the procedures for unlocking the charging port hatch described in the Household Portable AC Charging.
- Connect the power supply terminal:
  - Skip this step if an AC charging box is used for charging.
  - Skip this step if an AC charging pile equipped with a charging connector is used.
  - Use Mode 3 charging cable to connect your vehicle to the AC charging pile if no charging connector is provided.
- Connect the vehicle port:
  - Plug the charging connector into the port and make sure it is tight.
- Charging settings:

- Skip this step if an single-phase AC charging box or a public AC charging pile without any setting option is used.
- For public single-phase AC charging pile/box with settings, swipe the card or scan the QR code. See the user manual for charging pile/box details.
- The charging connection indicator  lights up on the instrument cluster.
- In the charging process, the instrument cluster displays relevant charging parameters and the charging sign.
  - At this point, you can schedule charging on the infotainment touchscreen. See **P89** for the configuration process.

### 3. Stopping charging

- End the charging:
  - Charging ends automatically when early stop time is due or charging is complete.
- Unplug the charging connector:
  - Disconnect as per the instructions in Using Mode 2 Charging Cable.
  - Disconnect the power plug.
  - Skip this step for AC charging piles equipped with a charging connector.
  - If an AC charging connector is used, it is recommended to unplug the charging connector from the vehicle first and then the plug from the charging point.
- Close the AC charge port door (see instructions for mode 2 charging).
- Store the equipment properly.
  - If using an AC charging pile/box, place the charging connector in its designated location in the charging pile/box.

- Store the equipment properly.

## Using DC Charging Piles\*

### 1. Equipment

- Charge the vehicle using a DC charging pile in a public place, which is typically installed at a specific charging station.
- Charging time: Refer to the charging time message on the instrument cluster.

### 2. Charging

- DC charging is achieved by connecting the DC charge port of the vehicle to a DC charging pile via its connector.
- Instant charging:
  - Unlock the vehicle, open the charging port cover and cap before charging.
  - Connect the vehicle port: Plug the charging connector of the DC charging piles into the DC charge port and lock it.
  - Operate the charging equipment to start charging.
  - The charging connection indicator  lights up on the instrument cluster.
  - In the charging process, the instrument cluster displays relevant charging parameters and the charging sign.



### 3. Stopping charging

- End the charging:
  - Charging ends automatically when early stop time is due or the charging is complete.
- Unplug the charging connector:
  - Press the mechanical lock button\* of the DC charging connector to pull out the connector.
- After DC charging with a charging pile, store the charging connector in its designated position properly.
- Close the charge port cap and the port door.

#### **WARNING**

- See "Charging Instructions" for charging safety warnings.

#### **CAUTION**

- After charging, if the charging connector cannot be pulled out, contact our customer service immediately.
- See the charging instructions for specific charging precautions.
- In case of high-temperature DC charging, the battery thermal management performance may be affected by the A/C in the passenger compartment, and the charging performance may degrade, resulting in an extended charging time. To ensure charging efficiency, it is recommended to keep the A/C off during charging.

### Smart Charging

- The charging mode can be set on the infotainment touchscreen or by

calling the BYD Assistant. To access the setting:

- On the infotainment touchscreen, tap → **Energy** → **Charging and Discharging** to go to the **Smart Charging** screen.
- Say "Hi BYD, start smart/scheduled charging", "Hi BYD, I want to make smart/scheduled charging" or "Hi BYD, please help me start smart/scheduled charging".
- Exit the Smart Charging screen by tapping the Back or Home button or calling the BYD Assistant.
  - To exit the screen, say "Hi BYD, end smart/scheduled charging" or "Hi BYD, exit smart/scheduled charging".

### Smart charging settings

- ① Scheduled charging switch
- ② Charging start and end time
- ③ Repeat cycle
- ④ Settings

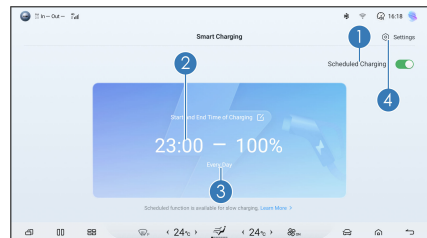

- The factory default setting is to charge the vehicle immediately. That is, scheduled charging is disabled.
- To schedule a charging, toggle the scheduled charging ON ①, set the charging start and end time ② and repeat cycle ③, then save the settings.
- After the schedule is set up, if you connect the charging connector or press the power button to power off

the vehicle, you will be reminded through the infotainment touchscreen that scheduled charging has been set. You can switch to instant charging if needed.

- You can tap the smart charging setting icon ④ to turn off the charging connector connected alert and power-off alert.

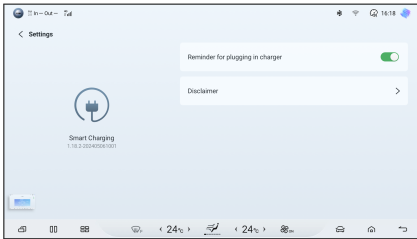

### CAUTION

- The smart charging function is developed for BYD's slow AC charging equipment only. Please disable this function when using slow AC charging equipment that is not certified by BYD. Otherwise, scheduled or immediate charging may fail due to no response from the equipment, resulting in low SOC or even low voltage of the high-voltage battery.

### REMINDER

- The instant charging option on the reminder screen is valid for the current schedule only. To cancel all schedules, toggle scheduled charging off on the corresponding setting screen.
- The smart charging function is only dedicated for AC charging piles provided by BYD. If you need to use this function via a public charging facility, please make sure

### REMINDER

that the facility supports vehicle-terminal reservation.

- In the event of low battery, the vehicle is charged to the minimum level before scheduled charging begins. In this process, the infotainment system still gives reminder messages for power-off and charging connector connection, and a related message is displayed at the lower part of the instrument cluster.
- The schedule setting is invalid for DC charging. Charging begins immediately after a DC charging connector is connected.

## Discharging Equipment

- This vehicle has the functions of internal discharging, external discharging, and discharging in the pickup bed. External discharging refers to vehicle-to-load (V2L) discharging.

### WARNING

- Do not touch any metal terminal of the discharging socket or the vehicle charge port during discharging.
- Stop discharging immediately if there are any abnormalities such as peculiar smell and smoke.
- See Charging Instructions for discharging safety warnings.
- Store the discharging equipment in a cool and dry place when it is not in use.
- When discharging, do not place the equipment in the pickup bed, under the front of the vehicle, or



### **WARNING**

near the tires to prevent it from falling and being rolled over by the vehicle and trampled on.

- Never use the equipment if the power strip cable becomes soft, if the discharging connector cable is worn out, if the insulation layer is cracked, or if any other damage occurs.
- Never use the equipment when the discharging connector or power strip is disconnected or broken, or when there is any sign of surface damage.

### **CAUTION**

- For precautions concerning use of the discharge connection device, refer to the charging equipment precautions.
- Before V2L discharging, ensure that the load is turned off.
- For V2L discharging, the engine starts at low vehicle SOC. Do not discharge in a confined space or near combustible and explosive materials.

### **REMINDER**

- The V2L function is recommended only when the vehicle SOC is high.
- When the vehicle is powered off, the static power consumption of the vehicle will increase if the V2L connection device is connected for an extended period without any output. Therefore, removing the discharging connector when the device is not used is recommended.

### **REMINDER**

- BYD's original V2L discharging equipment is required, and the vehicle discharging function may not work properly with non-BYD products.

## **External Discharging**

### **Check before discharging**

- To prevent serious personal injury, carefully read and observe the charging safety warnings that are equivalent to the discharging safety warnings in "Charging Instructions".
- To prevent damage to the charging equipment and the vehicle, carefully read and observe the charging precautions that are equivalent to the discharging precautions in "Charging Instructions".
- Ensure that the battery capacity of the vehicle to be discharged is not below 15%.
- In any of these cases, do not charge. Otherwise, personal injuries may occur due to short circuit or electric shock.
  - There are abnormalities of the V2L discharge device, such as cracked housing, worn cable, rusted plug, or foreign materials.
  - There is water or foreign material inside the charge port and that metal terminals are damaged by rust, corrosion, and other abnormalities.

### **Equipment**

- Vehicle-to-load (V2L) discharge device: The device consists of a discharging connector, a power strip, a cable, and a discharge gun protective cover.

- Its specifications shall comply with local standards. See discharge connection device for details.

### Starting discharging

1. Open the charge port door and port cap:
  - Before discharging, disarm the anti-theft alarm system.
  - See **P83** to unlock the charge port door and open the port door and cap.
2. Connect the discharge device:
  - Firmly connect the device to the charge port.
3. Start discharging:
  - After the switch button\* on the discharging socket is pressed, the socket indicator stays on (red), indicating that the socket can be used.
  - After the device is connected, discharge begins and discharging information is displayed on the instrument cluster.

### Stopping discharging

1. Stop discharging:
  - Disconnect the load.
  - In an emergency, proceed directly to the next step (not recommended).
2. Disconnect the discharging device:
  - With doors unlocked, remove the connector from the charge port. For discharging connectors with a mechanical button, press the button first and then remove the connector.
  - Close the charge port cap and the port door (see **P83**).
3. Organizing the equipment:
  - Store the equipment properly when discharging is complete.

### 3. Setting discharging duration

- After the discharge connector is plugged in, V2L discharging will be automatically toggled on and a countdown to discharging will be displayed on the instrument cluster and infotainment touchscreen. The default duration of a discharge set on the infotainment touchscreen is five hours.
- Go to the infotainment touchscreen →  → Energy → Charging and Discharging to access the "Vehicle To Load (VTOL)" setting screen.
- After the vehicle is connected to the discharging connector, toggle the "Vehicle To Load" on or off.

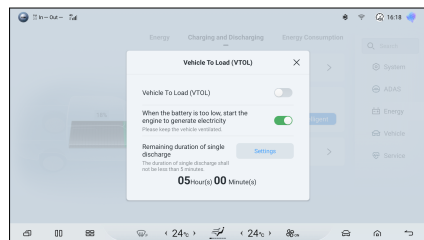

- When the vehicle is discharged to a low SOC with the ignition off, tap the "Start the engine to generate electricity when the power is too low" switch if it is necessary to start the engine to continue discharging.

#### REMINDER

- If the vehicle is discharged to a low SOC with the ignition on, it will automatically drive the engine to generate electricity without previous settings.
- Tap the "Settings" button of single discharge time to set the required discharge duration on the corresponding screen.

### CAUTION

- If the discharging connector is not connected, discharging does not start. Tap the "Vehicle To Load" button, and it lights up for a while and then turns gray, which is a normal phenomenon.
- Discharging may stop in advance in situations where the vehicle battery is too low, no gasoline is available to generate electricity, or the set discharging time is too long. This is a normal phenomenon.

## Internal Discharging

### Preparation before discharging:

- Make sure the ignition is switched on.
- If the surface of the socket is damaged, rusted, cracked or the connection is too loose, do not discharge.
- When the plug is stained or damp, cut off the power first. Wipe them with a dry and clean cloth to ensure that the discharging plug is dry and clean.

### Equipment

- Equipment specifications: Single-phase discharging. Its specifications shall comply with local standards. See discharging socket in your vehicle for details.

### Connecting the discharging equipment

1. Connect the equipment:
  - Plug the electrical equipment to the discharging socket in the vehicle.
2. Start discharging:
  - When the equipment is connected, the vehicle starts discharging.

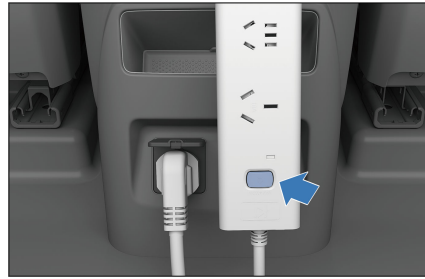

2. The  indicator lights up in the upper left corner of the instrument cluster, indicating that the socket in the vehicle is discharging.

3. Stop discharging:
  - Discharging can be stopped by unplugging the equipment or powering off the vehicle and then unplugging the equipment.

### CAUTION

- When the ignition is off, internal discharging cannot be used.

## Discharging in the Pickup Bed

### Preparation before discharging:

- Make sure the ignition is switched on.
- If the surface of the socket is damaged, rusted, cracked or the connection is too loose, do not discharge.
- When the plug is stained or damp, cut off the power first. Wipe them with a dry and clean cloth to ensure that the discharging plug is dry and clean.

### Equipment

- Equipment specifications: Single-phase discharging. Its specifications shall comply with local standards. See discharging socket in your vehicle for details.

### Connecting the discharging equipment

1. Connect the equipment:
  - Plug the electrical equipment to the discharging socket in the vehicle.
2. Start discharging:
  - When the equipment is connected, the vehicle starts discharging.



2. The indicator  lights up in the upper left corner of the instrument cluster, indicating that the socket in the vehicle is discharging.
3. Stop discharging:
  - Discharging can be stopped by unplugging the equipment or powering off the vehicle and then unplugging the equipment.

### WARNING

- Never use the discharging socket of the pickup bed in a thunderstorm or when washing the vehicle to avoid electric shock.

### CAUTION

- Note the socket parameter requirements for discharging in the pickup bed (or in the vehicle). Do not connect electrical equipment with excessive power or connect too many electrical equipment to avoid triggering the power-off protection. If the power-off protection is triggered, go to a

### CAUTION

BYD authorized dealer or service provider for a check.

## Target SOC Setting

- When the vehicle runs in dual-mode condition, the target SOC function is available to save battery power for operations such as rapid acceleration. When the vehicle runs stably, the battery SOC fluctuates around the balance point.
- The vehicle controller will memorize the last set SOC balance value.

### REMINDER

- When the engine has been started and the vehicle is running at a stable speed, part of the torque produced by the engine will drive the generator to generate electricity and charge the high-voltage battery.
- If the difference between the current SOC and the SOC balance value is large, the balancing time may be long.

### Target SOC setting

SOC balance value is the vehicle battery that users expect during driving. Users can set this value by sliding down the top status bar on the infotainment touchscreen to display the shortcut page or going to the SOC settings screen in the infotainment touchscreen →  →

### Energy.

- When the destination is convenient for vehicle charging, to make the best use of the electric driving power and reduce the fuel consumption, a lower target SOC is recommended.

- When the destination is not convenient for vehicle charging, a higher target SOC is recommended to improve the driving experience.
- For a better driving and riding experience, the vehicle will automatically adjust the target SOC according to the altitude and ambient temperature.
- AUTO/SAVE mode is related to the vehicle energy management priority:
  - AUTO: Prefer fuel economy, but also take battery power keeping into consideration.
  - SAVE: Prefer keeping vehicle battery power, and try to get close to the target SOC.

### Mode Memory

- When the vehicle SOC is high, the vehicle will automatically switch to EV mode when it is powered on. EV mode is recommended to be given priority to.
- When the vehicle SOC is moderate, the vehicle defaults to the previous dynamic mode when it is powered on. After power-on, you can manually select the mode with the mode switch.

### Electricity Generation by Pressing the Accelerator Pedal

- When the vehicle is in Park and HEV mode, if the SOC is lower than a certain value, pressing the accelerator pedal can generate electricity. Controlling the accelerator pedal depth can generate electricity with different power.

### REMINDER

- It is recommended not to press the accelerator pedal for a long time to generate electricity.
- In special working conditions, such as low or high temperatures, the power of electricity generated by pressing the accelerator pedal is limited by the charging power or the motor generating capacity, and the power changes on the instrument cluster.

## Charging Port Immobilizer System

In order to prevent the charging and discharging connector from being stolen, the vehicle charge port is anti-theft during charging and discharging. This function is disabled by default. Go to the infotainment touchscreen →  → **Energy** → **Charging and Discharging** to enable the charging port immobilizer system.

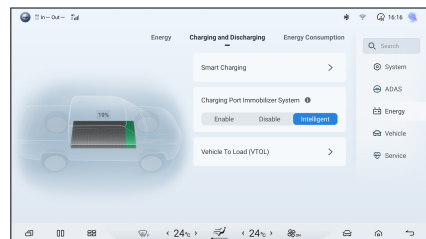

- When the function is enabled or in the intelligent mode, you can unlock the vehicle and unplug the charging connector during charging in the following ways:
  - With the ignition off, press the unlock button on the smart key to unlock.

- Press the microswitch next to the exterior handle of the driver's door to unlock.
- Press the central unlock button on the driver's door to unlock.
- The charging connector unlocks automatically when the vehicle is fully charged (for "intelligent" mode only).

No.	Charging Port Immobilizer System Status	Vehicle Door Anti-theft Lock Status	Vehicle Fully Charged or Not	Charging Connector Removable or Not
1	Enabled	Locking	/	No
2	Enabled	Start	/	Yes
3	Disabled	Locking	/	Yes
4	Disabled	Start	/	Yes
5	Intelligent	Locking	The vehicle is fully charged	Yes
			The vehicle is not fully charged	No
6	Intelligent	Start	/	Yes

- As shown in the table above, if the vehicle is in state 2/3/4/6, apart from the above-mentioned unlocking operations, you can unlock and pull out the charging connector by pressing its button (Configurations of the actual vehicle prevail). However, this may affect the service life of the charge port or charging connector. This is an emergency action that is not recommended to be taken frequently.

**! REMINDER**

- After unlocking the charging connector, it can be pulled out within 30 seconds. After 30 seconds, it will lock again, and the connector needs to be unlocked again for pulling out.
- Unlock the charging connector during charging, and a message

**! REMINDER**

displays on the instrument cluster: "Warm tip: Charging is paused. Please wait a while if you want to continue charging." At this time, the charging power is 0 kW on the instrument cluster. After waiting for 30 seconds or manually locking, the charging will continue.

- After the locked vehicle is fully charged, the charging connector will be automatically unlocked when the immobilizer system of the charge port is disabled. When this system is enabled or in the intelligent mode, the charging connector must be manually unlocked following the above steps.

### ! REMINDER

- Please close the charge port door after pulling out the charging connector.
- In the event of abnormality or function failure, contact a BYD authorized dealer or service provider.

## Emergency Unlocking of the Charge Port

When the charging connector cannot be unplugged due to failure of the anti-theft lock, unlock the charge port manually and unplug the charging connector.

1. There is a charging connector emergency cable on the fender below the charge port.
2. Open the cable latch and pull the emergency cable to unlock the charging connector.
3. Reset the emergency cable latch after unlocking.

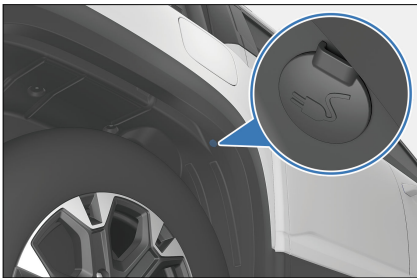

### ! REMINDER

- The cable is effective only when the vehicle is locked.
- In the event of abnormality or function failure, contact a

### ! REMINDER

BYD authorized dealer or service provider.

## Driving Range Display\*

- The range display mode can be set to improve driving experience. The default setting is standard mode.
- The corresponding settings can be made in infotainment touchscreen →  → **Energy** → **Energy** → **Range Display Mode**.
  - Standard mode: displays the driving range based on the result of comprehensive working condition test.
  - Dynamic mode: displays the estimated driving range based on the available battery power and current average energy consumption.
- The set driving range display mode is memorized by the system.
- When the vehicle is powered off and then on, the display mode set last time will be maintained.

### ! REMINDER

- When the dynamic driving range display mode is set:
  - The driving range that is displayed after a full charge may vary, depending on calculations of the energy consumed the last time the vehicle is used.
  - The driving range actually displayed will be adjusted based on the state of the vehicle's air conditioner, the driving mode (ECO, NORMAL, SPORT, etc.) selected, and the driver's driving

### REMINDER

habits, so as to match the vehicle's actual driving range.

## Regenerative Braking Intensity Settings

- During the driving, energy is recovered through regenerative brakes when the vehicle decelerates. For higher efficiency, do not accelerate or decelerate the vehicle unnecessarily.
- The corresponding settings can be made in  → Energy → Energy → Regenerative Braking Intensity.
  - Standard: When the accelerator pedal is released, the motor controller recovers energy in the standard level, and the vehicle deceleration is in the standard level.
  - High: When the accelerator pedal is released, the motor controller recovers more energy, and the vehicle deceleration is high.
- You can select the regeneration intensity based on the deceleration sense when releasing the accelerator pedal. Different deceleration senses deliver different driving experiences.
- The set regenerative braking intensity will be memorized. When the vehicle is powered off and then on, the regenerative braking mode set last time will be maintained.

### REMINDER

- Do not set the regeneration intensity when driving at high speed, as you may be distracted, resulting in accidents.

- Vehicle power is lower at low battery SOC than that at high battery SOC.

## Batteries

### High-Voltage Battery

- One of the main power sources of the vehicle is high-voltage battery, which is located under the vehicle floor and can be charged repeatedly. The main ways to charge the high-voltage battery through an external power supply are: Using Mode 2 charging cable, using AC charging piles, using DC charging piles\*, and using motor when the vehicle is braking, coasting, or the engine is on.

### CAUTION

- As the high-voltage battery is arranged at the bottom of the vehicle, careful driving is recommended in case of bumpy roads.

### REMINDER

- When the ignition is switched on, the high-voltage lines will be connected.
- For new cars with normal high-voltage battery status, the pure electric mileage will change due to different driving habits, road conditions, temperatures, and whether the electrical equipment is turned on or off.
- To prolong the battery life and ensure the battery safety, the vehicle switches to trickle charging mode at high SOC,



### REMINDER

and the charging time may be prolonged.

- Due to the chemical characteristics of the battery itself, the battery capacity of vehicles that have been used for a period of time has natural degradation, and their pure electric mileage will reduce. When you find that the pure electric mileage of your car has decreased, it is recommended to go to a BYD authorized dealer or service provider for check. The store-side inspection can confirm whether the reduction of pure electric mileage is normal.

### High-Voltage Battery Maintenance

- For optimal battery performance, use an AC charging connector to fully charge the battery regularly, and the recommended frequency is once a week at least.
- If the vehicle is going to be idle for over seven days, it is recommended to keep the SOC between 40% and 60% to extend vehicle service life. If the vehicle is going to be idle for over three months, charge the battery fully and discharge it down to 40% to 60% SOC, to avoid battery degradation or even damage.

### Low Temperature Heating for High-Voltage Battery

- When the outside temperature is low, the high-voltage battery heating system will be activated and heat up the battery to improve the low-temperature charging speed and ensure the vehicle power and driving range.

### WARNING

- Non-professionals must not open the high-voltage battery pack. Any organization or individual shall bear the responsibility for environmental pollution or accidents caused by disassembling or dismantling the battery without authorization.

### CAUTION

- When the high-voltage battery fails, it is recommended to contact a BYD authorized dealer or service provider.

### REMINDER

- The normal working temperature range of the high-voltage battery is -35°C to 60°C.
- Charging time may be prolonged when the working temperature of the high-voltage battery is high or low.

### Recycling the High-Voltage Battery

How to scrap an NEV:

1. Take the vehicle to the BYD recycling service provider that will assess the residual value of the high-voltage battery.
2. Take the assessed vehicle to the recycling organization to disassemble the high-voltage battery.
3. Take the battery to the recycling service provider which will buy back the battery.

## **WARNING**

- New energy vehicle owners have the responsibility and obligation to hand over waste high-voltage batteries to the recycling service outlet. Anyone who hands over a used high-voltage battery to any other organization or individual, or removes/disassembles a high-voltage battery, shall be liable for any environmental pollution or safety incident so caused.

## Low-Voltage Battery

- The low-voltage battery of this model is provided with the intelligent charging function. When the high-voltage battery of the vehicle is fully charged, the low-voltage battery may be charged by the high-voltage battery automatically to increase its battery life.

## **REMINDER**

- It is normal that intelligent charging with the ignition off produces a sound which is heard when the ignition is switched on.
- When leaving the vehicle, make sure all electrical equipment is turned off and the doors are closed.

## Waking up the Vehicle from Low SOC

- **Wake-up by the driver's door microswitch**
  - The low-voltage battery features the dormancy wakeup function. The low-voltage battery may have entered a dormant state after long-term parking. In that case, the vehicle cannot be located or unlocked with

the smart key. At this time, press the microswitch on the driver's door handle (See **P55**) to activate the low-voltage battery. After the vehicle is unlocked, it can be used normally.

- **Wake-up by jump starting**

- When the vehicle cannot be woken up and unlocked by the driver's door microswitch, use the mechanical key to open the door. Then, use a 12V power supply to start the vehicle by two specially designed cables for the jump start. In this case, the low-voltage battery SOC is low. The instrument cluster may display "The low-voltage battery SOC is low, and the vehicle is going to be powered off", and the vehicle will become dormant again. Start the vehicle immediately and keep it started for over 15 minutes to ensure that the low-voltage battery is fully charged. The jump start can only be carried out through the special interface of the under-hood PDB.

① Positive terminal for under-hood PDB jump starting

② Negative terminal for jump starting

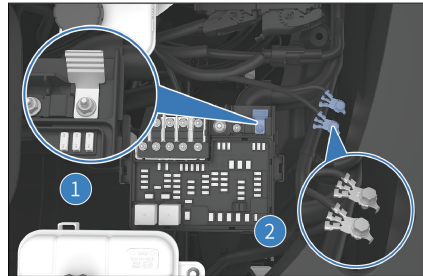

- If the vehicle cannot be woken up and started by the above steps, it is recommended to contact a BYD authorized dealer or service provider immediately.

**⚠ WARNING**

- Do not connect the vehicle with other vehicles for a jump start before it is powered on. Otherwise, the low-voltage battery may be damaged.
- If the low-voltage battery SOC is too low or the battery fails, jump starting may be required. Please carefully read and strictly follow the jump starting instructions in this manual.
- The low-voltage battery contains an intelligent control module. To prevent battery damage, do not disassemble or damage this battery without permission, except in an emergency.
- Disconnect the negative terminal of the low-voltage battery and the low-voltage maintenance switch connector before performing parts replacement and vehicle repairs.

**⚠ CAUTION**

- It is recommended that the jump starting be done under the guidance of professionals, as the space for operating the underhood PDB is limited and circuit-based risks are present.
- Do not clean the low-voltage battery with liquid to prevent ingress.

**Intelligent Charging**

When the low-voltage battery power is low, the intelligent charging will be activated to increase the battery life of low-voltage battery. When the high-voltage battery is low, the engine may start to generate electricity to meet

the needs of intelligent charging. This model is provided with the intelligent charging function. It is not necessary to disconnect the low-voltage battery's negative terminal when the vehicle is to be parked for a long period.

**⚠ CAUTION**

- When the low-voltage battery power is low, the intelligent charging will be activated, resulting in the decrease of high-voltage battery SOC or pure-electric driving range displayed on the instrument cluster, which is a normal phenomenon.
- After the vehicle is locked, when the power of the high-voltage battery is low enough to trigger the engine to generate electricity, a small amount of fuel will be consumed and a small amount of exhaust gas will be discharged.

**Usage Precautions****Break-in Period**

- If the powertrain is hard to start or frequently stops turning, inspect the vehicle immediately.
- If the powertrain makes any abnormal sounds, stop the vehicle for inspection.
- If the powertrain has severe coolant and oil leakage, stop the vehicle for inspection.
- The powertrain needs break-in. It is recommended that this be done within the first 2,000 km in HEV-ECO mode by smooth driving, instead of high-speed driving. The following practices can effectively prolong vehicle service life:

- Avoid flooring the accelerator pedal when starting and driving the vehicle.
- Avoid speeding.
- Avoid emergency braking within the first 300 km.
- Do not maintain a high or low speed for too long.
- Do not use the vehicle to tow other vehicles within the first 2,000 km of mileage.
- During the break-in period, the proportion of driving in HEV mode shall not be less than 50%.

## Trailer Towing

### Towing capacity

- The towing capacity depends on various factors such as vehicle specifications, loads, road conditions, and trailer specifications. For driving safety, avoid speeding and overloading. See the table below for specifications.
- The total towing weight must not exceed the limits below:

Item	Parameter	Comment
Maximum allowed towing capacity (braked)[kg]	2500	Maximum total towing capacity allowed when the trailer is braked
Maximum towing capacity (unbraked)[kg]	750	Maximum total towing capacity allowed when the trailer is unbraked
Maximum vertical load (kg)	250	Maximum vertical load allowed on ball joint

1. Maximum allowed towing capacity is total trailer weight, which includes all cargos and additional equipment.
2. Maximum vertical load refers to the downward pressure exerted by the weight of the trailer on the trailer hitch when the vehicle and the trailer are stationary.

#### CAUTION

- When the vehicle is loaded with certain equipment, personnel or goods, the vertical load will be reduced, thus weakening the towing capacity. In towing mode, the vehicle shall not exceed the gross vehicle weight rating (GVWR). GVWR is printed on the vehicle nameplate.

#### WARNING

- Drivers must be qualified for towing the total mass (including both the vehicle and trailer).
- The vertical load on the device connecting the towing vehicle and the trailer must be at least 4% of the total trailer weight or 25 kg (whichever is heavier), without exceeding the maximum allowable vertical load on the ball joint of the trailer. Unbalanced

 **WARNING**

loads on trailer wheels or heavier loads at the rear may cause the trailer to sway, resulting in losing of vehicle control.

- Make sure no one rides in the trailer during towing.
- The maximum uphill gradient allowed is 12% during towing.
- Always ensure that the cargo is secured in the trailer and cannot move. Dynamic load movement may cause loss of vehicle control, resulting in serious injury or death.
- To avoid potential accidents and serious injury, never exceed the maximum towing capacity of the trailer hitch or maximum vertical load of the ball joint.
- To avoid loss of vehicle stability or danger, never attempt to tow a trailer in the following cases:
  - Using a faulty tire.
  - Using a temporarily repaired tire.
  - Using a spare tire.
- Please observe applicable local laws and regulations regarding towing. Do not modify the vehicle without permission.
- When a trailer is equipped with an electromagnetic brake, confirm with the trailer manufacturer for the installation of the electromagnetic brake synchronizer.
- BYD does not assume any responsibility for vehicle damage or injuries resulting from failure to comply with the proper guidelines

 **WARNING**

of towing in this manual. Damage caused by towing a trailer is not covered by the warranty.

**Tire pressure during towing**

- To tow a trailer, adjust the tire pressure to accommodate additional loads. Keep front tires inflated to 2.5 bar and rear tires to 2.5 bar.
- For towing, the technically permissible maximum mass on the rear axle may be exceeded by no more than 15% and the technically permissible laden mass of the vehicle may be exceeded by no more than 100 kg. In these instances, the vehicle speed must not exceed 100 km/h.

**Rearview mirror and holders for towing**

- The field of view of the rearview mirror during towing should comply with the laws and regulations. If the original rearview mirror does not meet the using conditions, install a suitable trailer rearview mirror. The trailer rearview mirror can be attached to the surface of the side mirror or clamped with a holder on the mirror frame. For detailed installation and usage instructions, refer to manuals of the trailer rearview mirror.

 **WARNING**

- Do not tow a trailer in the break-in period.
- Before towing, be sure to:
  - Inflate tires to the specified cold tire inflation pressure.
  - Adjust the interior rearview mirror and side mirrors to provide clear rear views without significant blind spots.

 **WARNING**

- Keep the towing vehicle and the trailer horizontal when the trailer hitch is used. If the connection device tilts up and down after connection, confirm whether the vertical load of the towing device is within the allowable range of the vehicle.
- Check that trailer lights and turn signals operate normally.
- Check that the trailer brake works normally.
- Check that all trailer hitch components, accessories, and electrical connectors are in good condition and properly connected. If any problems occur, do not tow the trailer.
- Check that wheel chocks are available.
- Check that trailer loads are evenly distributed.
- Place heavy objects in the trailer near the axle whenever possible to avoid the interference with the combination vehicle in case of sway.
- Make sure the trailer cable does not contact or drag on the ground and has enough slack for turning.
- Store the trailer hitch properly when it is not used.
- Starting to drive:
  - Start the vehicle smoothly and avoid sudden acceleration and emergency braking, or the vehicle may be out of control due to slipping especially on a slippery road.

 **WARNING**

- Crosswinds or rough roads can cause vehicle sway, leading to difficulties in controlling the vehicle. In any situation, whenever you notice any slight sway of the vehicle, hold the steering wheel firmly with both hands and slow down gradually. Never attempt to eliminate sway by increasing the speed.
- An unloaded towing vehicle combined with a loaded trailer will cause improper load distribution. If this is unavoidable, drive slowly.
- Braking:
  - Sudden braking may cause slipping, bottom scratches, or loss of control.
  - Be sure to at least double the normal following distance because the vehicle braking distance increases during towing.
- Overtaking:
  - A towing vehicle requires a longer distance to overtake.
- Reversing:
  - Be careful to operate and reverse at low speed because reversing while towing is difficult.
- Turning:
  - When making a turn, signal in advance, avoid bumps or sudden turns whenever possible, and keep the vehicle steady.
  - While turning, ensure a larger radius than usual to prevent

**⚠ WARNING**

the trailer from colliding with curbs, road signs, trees, or other obstacles.

- Parking on a slope:
  - Avoid parking on a slope. If this is absolutely necessary, the grade must not be greater than 12% and be sure to chock the wheels:
    1. While one person presses and holds the brake pedal, a second person places wheel chocks under the wheels on the downhill side.
    2. When chocks are in place, release the brake pedal and ensure the chocks can bear the weight of the vehicle and trailer (with AVH disabled).

**⚠ WARNING**

3. Shift into Park and ensure that the electronic parking brake (EPB) has been activated.

- If parking on a slope is necessary, always ensure that all trailer wheels have been securely chocked. Failure to do so can result in serious vehicle damage, injury, or death.

**⚠ CAUTION**

- Towing can lead to the degradation of the vehicle driving power, economy, and durability, which is a normal phenomenon.
- When a trailer is coupled, it is normal for the trailer's LED taillights to flash slightly.

**General towing troubleshooting**

<b>Fault</b>	<b>Possible Cause</b>	<b>Solution</b>
Failure to activate towing mode	Vehicle speed is not 0	Engage EPB, and activate the towing mode again when the vehicle is stopped.
	Cable disconnected or poor cable connection.	Unplug the cable and reconnect it.
Trailer light fault	Poor cable connection	Unplug the cable and reconnect it.
	Blown fuse	Contact a BYD authorized dealer or service provider.
Trailer indicator turning red	Accidental disconnection of trailer cable during driving	Pull over as soon as possible and check whether the cable is properly connected; if not, reconnect it. If the cable is damaged, repair it as soon as possible.

**Towing mode**

- Equipment

① Trailer hitch

② Electrical connection plug

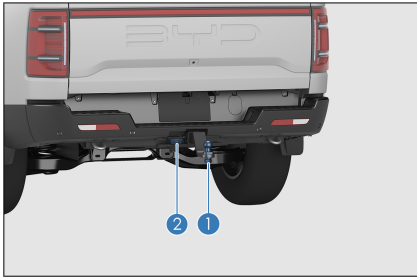

**! REMINDER**

- To avoid rusting, store the trailer hitch properly when it is not in use.

- Installing the trailer hitch

1. Insert the trailer hitch sub-assembly ② into the square hole receiver assembly ① until the hole on the square tube of the trailer hitch sub-assembly is aligned with the hole on the square tube of the square hole receiver.

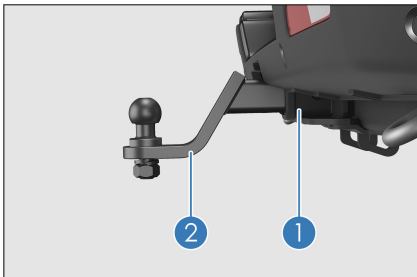

2. Insert the bolt ① into the hole, and then insert the bolt lock ② into the bolt. To assemble the bolt lock as shown in the illustration.

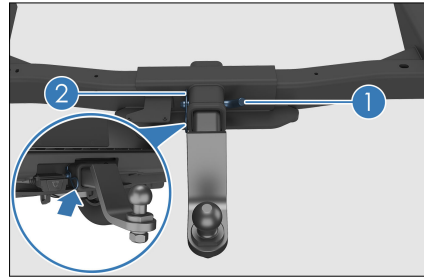

3. Check that the hitch is firmly inserted into the square hole receiver. Try pulling down on the hitch to confirm that the hitch does not drop.

**! WARNING**

- Use a hitch that matches the vehicle when towing.
- The trailer hitch of this vehicle is only used for towing the trailer. Do not use it for freeing the vehicle itself or rescuing trapped vehicles, to avoid damage to the vehicle or even do harm to personal safety.

- Removing the trailer hitch

1. Pull out the bolt lock.
2. Pull out the trailer hitch and put it in a safe place for storage.

**! REMINDER**

- If the hitch does not lock into the housing, it may fall out when pulling down.
- To maintain the hitch, regularly grease the surface with non-resinous grease.

- Electrical connection

- All trailers must be equipped with taillights, brake lights, side indicators and turn signals. To provide power for trailer lighting, a built-in 7-pin



electrical connector is provided for the hitch. When the vehicle is stationary, plugging the trailer plug into the vehicle electrical connector will automatically activate the towing mode. If the trailer connector is not 7 pin, an adapter is needed.

- Standards for power intake port is AS4177.5. The pin functions are as follows:



Pin Number	Function	Color
1	Left turn signal	Yellow
2	Reverse light	Black
3	Ground	White
4	Right turn signal	Green
5	12V power	Blue
6	Brake light	Red
7	Driving light	Brown

**! WARNING**

- Use only the electrical connection device designed by BYD. Do not directly splice or connect the trailer's electrical circuit by other methods. It may damage the electrical system and cause faults.

**! CAUTION**

- Ensure that all electrical connections and trailer lights

**! CAUTION**

- operate normally before and during towing.
- Do not directly wash the electrical connection devices with a high-pressure water jet. Doing so may result in water ingress and damage the device.

**Guide for the towing mode**

- Preparation before connecting

- Take out the trailer hitch and insert it into the reserved interface at the rear of the vehicle.
- Shift into Reverse, and enable the towing mode on the panoramic view screen.
- Reverse the vehicle with the aid of the towing assist guide cursor in the reverse image, and make the ball joint of the trailer hitch close to the mechanical connecting device of the vehicle to be towed. Park the vehicle and then get off to connect.
- Connecting the two vehicles
  - Connect the two vehicles according to the instructions of the trailer.
- When the vehicle is in Park, it automatically enters the towing mode after the cable is connected.
- Indicator detection
  - Automatic: Indicator detection automatically starts 15s later after the cable is connected.
  - Manual: On the infotainment touchscreen →  → **Vehicle** → **Towing Mode**, enable automatic indicator detection, and the detection starts after 15s.
- The following driver assistance functions are disabled in towing mode, please drive with caution.

Number	Function
1	Adaptive cruise control
2	Intelligent cruise control
3	Rear cross traffic alert
4	Rear cross traffic braking
5	Rear collision warning
6	Lane collision warning
7	Automatic emergency braking
8	Emergency Lane Keeping Assist
9	Front cross traffic brake
10	Lane departure warning

 **WARNING**

- Never connect or disconnect the cables and trailers when the vehicle is not in Park, or hazards may occur.
- It is recommended to connect or disconnect the cables when the

 **WARNING**

vehicle is powered off to avoid accidental electric shock.

 **CAUTION**

- The maximum speed is limited in towing mode to ensure safety.

**CAUTION**



- When opening the tailgate in towing mode, pay attention to the distance and clearance between the tailgate and the trailer.
- In towing mode, the driving mode is NORMAL by default and cannot be changed.

**CAUTION**

- When the vehicle is in Park, disconnect the cable and then shift into other gears to exit the towing mode for driving safety.

**Towing mode indicator**

- The towing mode indicator  is displayed on the instrument cluster.

Function	Vehicle Status	Indicator Status	Indicator
Trailer	Normal	Solid blue	
	Abnormal	Solid red	

- It is off when the trailer cable is not connected.

**Influence of trailer towing on mileage**

- Towing increases vehicle weight and drag, thus decreasing the available driving range. The route planning function adjusts the estimated mileage based on the energy consumption in the historical towing (initial calibration value adopted in case of first towing), and dynamically adjusts it based on the actual energy consumption during driving.

**How to solve trailer sway**

- When trailer sway is detected, ESC applies braking accordingly to minimize sway. The ESC indicator  flashes on the dashboard. When the vehicle brakes automatically for the sway, the indicator will be flashing even if you step on the brake pedal until the vehicle becomes stable.

**Driving Safety Precautions**

**No Drunk Driving**

Even a small amount of alcohol can reduce a driver's ability to respond to traffic condition changes. The higher the level of alcohol, the less responsive the driver will be. Therefore, never drive while under the influence.

**No Speeding**

Speeding is a major cause of fatal accidents. Faster speeds generally entail higher risk. Therefore, maintain a speed safe for the road traffic conditions.

**Keeping the Vehicle Safe for Driving**

Tire bursts and mechanical faults are extremely dangerous. To reduce the possibility of such faults, frequently check the vehicle's condition, and regularly complete the specified inspections.

 **WARNING**

- Any driver must possess a driver's license before driving a vehicle.
- Do not drive when fatigued.
- Always follow the traffic regulations when driving a vehicle.
- During driving, please focus on driving, and avoid activity unrelated to driving (such as making / receiving phone calls and adjusting buttons).

## Suggestions for Vehicle Use

Suggestions for prolong the high-voltage battery life:

- Before the vehicle is stored for a long time, it is recommended to charge the battery fully and discharge it down to 40% - 60% which is not too high or too low, and close the doors and windows.
- Before the vehicle is stored for a long time, it is recommended to fully charge and discharge it once every three months, and then charge it to 40% - 60% for storage.
- During operation of the vehicle, if the SOC indicator bar on the instrument cluster enters the red alert area, it indicates that the battery SOC is low. In this case, charge the vehicle in time and avoid driving with low SOC for a long time.
- During operation of the vehicle, it is recommended to use the on-board charging equipment to fully charge the vehicle once every one to two weeks.
- When the temperature is high, avoid long-term storage of vehicles at full power. It is recommended that the

vehicle be discharged to below 95% after it is fully charged.

- When the temperature is very low or very high, it is recommended that the vehicle should not be parked outdoors for a long time.
- During operation of the vehicle, avoid repeated rapid acceleration or deceleration whenever possible.
- During operation of the vehicle, avoid driving the vehicle continuously for a long time; otherwise, the excessively high battery temperature will affect vehicle performance.
- If a fault indication is displayed on the instrument cluster during driving, it is recommended to contact a BYD authorized dealer or service provider for inspection as soon as possible.
- When the high-voltage battery temperature is high, the vehicle performance will be limited to some extent. In this case, stop the vehicle and wait until the temperature drops before operating.

 **WARNING**

- In low or high temperature environments, the pure-electric driving range is somewhat reduced compared with the normal temperature and power performance will also be affected.

 **CAUTION**

- If the pure-electric driving range drops to 0 on the instrument cluster, the battery must be charged. If it is not charged within seven days, the battery will suffer permanent damage. Such damage is not covered by BYD warranty terms.

**CAUTION**

- Driving range depends on many factors, such as the vehicle's available power, vehicle age (current battery life), weather, temperature, road conditions and driving habits.

## Fuel

### Fuel Selection

- The use of correct fuel is the basis for realizing the best performance of the engine, and also the key to controlling emissions and protecting relevant components.
- Please use unleaded gasoline that meets local standards.

**CAUTION**

- Do not use leaded gasoline. The use of leaded gasoline leads to the failure of the three-way catalytic converter and the malfunction of the control device for exhaust pollution, as well as the increase in maintenance costs.
- The engine damage or excessive emission caused by the use of improper fuel is not covered by the warranty.
- The use of low-grade or inferior gasoline reduces the service life of the engine.

### Refueling

- The fuel door is located on the left side of the vehicle, so park the vehicle with its left side close to the fuel pump.
  - Turn the vehicle off.
1. Open the fuel door.

- After the vehicle is powered off, press the driver's pressure relief switch, wait for about 1-15 seconds, and press the fuel door to open it after the instrument cluster prompts that the fuel tank cap has been unlocked.

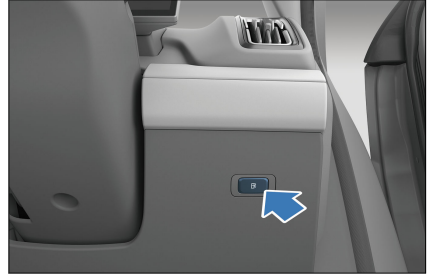

2. Rotate the fuel tank cap counterclockwise to remove it.

- Wait for 5-10 seconds and rotate the fuel tank cap counterclockwise to remove it. During this period, the fuel tank cap idling is normal. You may hear a "hiss" sound due to the air supply to the vacuum in the fuel tank.
- Connect the fuel tank cap to the refueling funnel with a cord to prevent inadvertent loss of the cap. While refueling, place the fuel tank cap on the bracket of the fuel door.

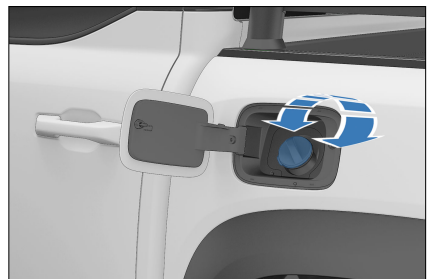

3. After refueling, screw up the fuel tank cap clockwise and then close the fuel door.

### **WARNING**

- Since the fuel is flammable and combustible, pay attention to the following matters during refueling:
  - It is recommended to add fuel outdoors.
  - Do not smoke during fuel filling, so as to prevent sparks or open flames, which are easy to cause combustion.
  - Fuel filling and charging must be done separately. Do not refuel the vehicle with the charging connector connected, which should be keep a safe distance away from combustible products, or it may result in risk of damaged equipment or injuries when the operation of plugging/unplugging the charging connector is not done by rule, such as burning fuel.

### **CAUTION**

- Due to different pressures in the fuel tank, the time from the fuel tank pressure relief to the fuel door unlocking will be different, and it is normal to see different waiting time of fuel door unlocking.
- Stop filling after the filler nozzle is automatically cut off. Do not overfill the fuel tank, so as to leave some space for fuel expansion due to the temperature change.
- Check whether the fuel tank cap is tightened and whether the fuel door is closed in time after refueling.

### **CAUTION**

- If the fuel tank cap is not tightened,  may lights up on the instrument cluster.
- If the fuel adding is not completed within 15 minutes after the fuel door is opened, please close the door, open it, and add fuel again, otherwise the reverse spray of oil may occur during refueling.
- If the fuel tank cap is idling and cannot be opened, contact a BYD authorized dealer or service provider. Emergency opening of fuel filler cap: Lever the blanking cap off, which is in the center of the fuel tank cap handle. Insert a slender guide rod (such as a gel pen refill) into the small hole till the end and keep, and rotate the handle counterclockwise to take the fuel tank cap off.

## **Saving Fuel and Extending Vehicle Service Life**

- Saving fuel is simple and easy, and it helps prolong the vehicle's service life. Here are some tips for saving fuel and repair costs:
  - Constant speeds save fuel. Sudden acceleration, sharp turning, and emergency braking consume more fuel.
  - Speeds should be kept constant according to traffic conditions. Each deceleration or acceleration of the vehicle consumes additional fuel.
  - Using cruise control under proper driving conditions for fuel saving.
  - The use of the A/C brings additional load to the engine, resulting in larger fuel consumption. Turn off the A/C

to reduce fuel consumption. When outside temperatures are moderate, use fresh air mode for ventilation.

- Make sure tire pressure is correct. Insufficient tire pressure causes tire wear and fuel waste.
- Do not load unnecessary weight on the vehicle. Excessive weight brings additional load to the engine, resulting in large fuel consumption.
- Do not stop to warm up the engine, and start driving slowly immediately after starting, which can make the engine reach the working temperature as soon as possible and reduce the emission of harmful substances. Unless in extreme low temperature environment, you can keep a high idle speed by lightly stepping on the accelerator pedal when the vehicle is in Neutral under "HEVSPORT" mode, and then start driving slowly after warming up.
- Cold start: When the engine is cold, do not run it at a high speed or drive with the accelerator pedal pressed to a deep position immediately after starting. It is recommended to drive slowly after starting.
- Avoid long-term idling of the engine. If you are in a low-traffic area and have to wait for a long time, it is better to turn off the engine and start it later.
- Avoid engine deceleration or overspeed with loads. Select the appropriate speed gear according to the road conditions.
- Avoid continuous acceleration and deceleration. Frequent stop and start cause fuel waste.
- Avoid unnecessary parking or braking. Maintain a stable speed and observe traffic lights to minimize the number of stops. When driving on

the road without traffic lights, keep a proper driving distance from the vehicle ahead to avoid emergency braking, which may also reduce the brake wear.

- Do not drive on roads with heavy traffic or traffic jams as much as possible.
- Do not always put your foot on the brake pedal if unnecessary, because this may cause premature wear, overheating, and consumption of a large amount of fuel.
- Keep moderate speeds in motorways. Higher vehicle speed consumes more fuel. Keep the vehicle speed within the economical range of speed to save fuel.
- Keep front wheels properly aligned. Avoid collision with curbstones and drive slowly on rough roads. An inaccurate front wheel alignment causes excessive tire wear and increases the engine load and fuel consumption.
- Keep the chassis clean and free of mud. This not only reduces the weight of the vehicle body, but also prevents corrosion.
- Adjust the vehicle to keep it at its best working status. Such conditions as dirty air filters, much carbon deposit in spark plugs, dirty, deteriorated or viscous engine oil and lubricating oil, and unadjusted brakes worsen the engine performance and waste fuel. Regular maintenance must be carried out to ensure a long service life of all components and reduce operating costs. If the vehicle is often driven under severe conditions, the maintenance interval shall be shortened.

## REMINDER

- Do not coast in Neutral gear.

## Carrying Luggage

- This vehicle has multiple storage spaces.
- The glove box, door bins, and seatback pockets are designed to store small and light items, while the pickup bed is used to store larger and heavier items.
- Overloading or improper accommodation may affect maneuverability, stability and normal operation of the vehicle, and reduce its safety.
- Make sure the vehicle's total load (vehicle + passengers + luggage) remains within the specified maximum weight.
- Please read the following information carefully before carrying luggage.

## WARNING

- Overloading and improper loading affect the maneuverability and stability of the vehicle, and may even result in collision accidents.
- Observe the total load limits and other loading guidelines in this Manual.
- Do not carry articles with strong magnetism to avoid interference with the normal running of the vehicle.

## Carrying Items in the Passenger Area

- All items that could be thrown inwards and thus injure occupants in case of a

collision must be properly placed and secured.

- Ensure that items placed on the floor behind the front seat do not roll under the seat, so as to avoid affecting the driver's ability to control the pedals or normal seat adjustment. Do not stack items to a height taller than the front seats' seatbacks.
- Make sure the glove box is always closed while driving. If the glove box is open, the occupant's knees may be injured in case of a collision or an emergency stop.

## WARNING

- Do not pile up toys in the vehicle, as this may affect driving safety and present a hazard to the children, especially in case of emergency braking or collision.

## Loading the Pickup Bed

Pickup bed anchor points

- Place luggage evenly in the pickup bed. Put heavier items at the bottom and as far as possible.
- Secure goods with ropes or straps so that they will not move while driving.





### REMINDER

- Ensure that the goods are properly secured before driving.

### CAUTION

- For vehicle driving safety, ensure that the length and width of the goods do not exceed the pickup bed, and their height is as low as possible.
- To prevent falling, fix the goods with tarpaulins or ropes.
- Do not use roll cages\* and the tailgate to support goods.
- Load the goods evenly to avoid movement and partial overload of the vehicle, or even damage to the pickup bed and the frame.

### WARNING

- Make sure no one is riding in the pickup bed during driving.
- Never throw unextinguished cigarette butts, matches and other fire sources out of the vehicle, otherwise they may be blown into the truck bed by the wind, causing a fire and even personal injuries.
- Do not put flammable and explosive materials such as gasoline containers and spray cans in the pickup bed to avoid fires or even personal injuries.

#### Roof Rack

- Storing luggage on the roof rack will increase overall energy consumption and change the way the vehicle drives and handles.

- When installing the roof rack, please read and follow the manufacturer's instructions.
- Try to load the roof rack evenly and keep the center of gravity low. Loads on the roof rack may elevate the overall center of gravity, which might alter your driving experience.
- When driving a heavily loaded vehicle, take extra precautions, such as decelerating and increasing the braking distance.
- The maximum recommended load of the roof rack is: 75 kg in dynamic state, and 300 kg in static state. Among them, the load includes the weight of the beam, luggage frame and other accessories mounted on the rack.

### CAUTION

- Luggage must not be put on the roof metal sheet directly. The roof metal sheet is not designed for loading.
- Use the roof rack properly and fasten the luggage on the beam.
- Make sure the luggage is securely fastened on the roof rack before driving and during parking.

## Risk of Carbon Monoxide (CO) Poisoning

- The engine exhaust contains CO gas. If the vehicle is properly maintained, CO may not enter inside during normal driving.
- Check the exhaust system for leakage under the following conditions:
  - The exhaust sound is abnormal.

- The vehicle has been subjected to accidents that may damage the bottom of the vehicle.

### **WARNING**

- CO gas is toxic. Inhalation of CO can result in loss of consciousness and even threat to life. Any enclosed environment and activities that can cause CO poisoning should be avoided.
- High-concentration carbon monoxide gas will quickly concentrate in closed areas, such as garages. Do not start the engine when the garage door is closed. Even if the garage door is open, the running time of the engine should be limited to the extent that the vehicle can be driven out of the garage.

## Wading into Water

- Check water depth - it must not exceed the vehicle's allowable maximum wading depth - before driving into flooded areas.
- If crossing a flooded area is necessary, turn off the A/C before starting the vehicle, slow down, and keep acceleration steady to slowly cross over. Do not release the accelerator pedal midway, or the exhaust back pressure is generated to suck water into the engine and causes serious damage.



- Never stop and reverse the vehicle, or turn off the engine in flooded areas.
- After crossing over, gently press the brake pedal several times to dry out the brake disc, so as to recover brake performance as soon as possible.
- Be careful when driving through deep water, as brakes may get wet.

### **WARNING**

- It is not recommended to wade into high water unless necessary.
- Do not wade in water whose depth exceeds the vehicle's maximum wading capacity (700mm).
- If there is any water or mud on the brake disc, it may result in delayed brake reaction and extended braking distance, so attention should be paid to prevent accidents.
- Carefully apply any wet brake, and remove ice or water on it.
- Avoid emergency braking as far as possible after driving through any waterlogged road section.
- No water ingress into the engine is allowed. If the vehicle drives on a low-lying and waterlogged road, prevent water from entering the engine, otherwise the engine will be damaged seriously. Such

## WARNING

damaged is not covered by the vehicle's warranty

- When the vehicle is wading in high water, if it is in EV mode, do not manually switch to HEV mode, and prevent the vehicle from automatically switching to HEV mode due to low battery, which can lead to water ingress during engine startup and cause engine damage.
- During wading, if it is found that water enters the engine intake pipe or the engine fails, do not start the engine again, otherwise it may be damaged.
- After the vehicle is driven through waterlogged road sections, vehicle components, such as drive system, driving system and automotive electric system, may also be damaged seriously. Any vehicle fault or damage so caused will not be covered by the quality warranty.
- Be sure to find a sheltered place when charging the vehicle on rainy days. If the vehicle is immersed in water or wades through water over the doorsill, which may cause water ingress in high-voltage components, promptly contact a BYD authorized dealer or service provider for testing and troubleshooting.
- Do not drive the vehicle on roads where the depth of accumulated water exceeds half of the tires.

### **Influence of water ingress in high-voltage components:**

- Water getting into high-voltage components, which are electronic

devices, may not be fully dried out by any means.

- Water ingress seriously compromises insulation of high-voltage components, and the conductive substances in water may lead to internal short circuit of high-voltage components or such risk of the entire high-voltage system. This significantly affects the safety and service performance of the vehicle.
- The reduced ingress protection rating and voltage withstanding performance due to water in high-voltage components pose a high safety risk.

## Fire Prevention

**To prevent vehicle fires in a timely and effective manner, pay attention to the following during use of the vehicle:**

- Do not press the accelerator pedal continuously. Otherwise, the engine will always run at a high speed.
- No flammable or explosive items are allowed in the vehicle.
  - Temperatures may reach over 70°C in a vehicle exposed to direct sunlight in summer. Therefore, flammable and explosive items, such as lighters, cleaning agents and perfumes, stored in the vehicle can cause a fire or even explosion easily.
- Make sure cigarettes are thoroughly put out.
  - Smoking is harmful to your health and may cause a fire. Cigarettes that not thoroughly put out may cause a fire.
- It is recommended to go to a BYD authorized dealer or service provider for regular vehicle checks.

- Check oil leakage in the engine compartment regularly, and clean up the oil dirt and oil stain on the engine in time.
- Check vehicle wiring, electrical connections, wiring harnesses, insulation, and fixed positions regularly. Deal with identified problems promptly.
- Do not refit vehicle wiring or add any unauthorized electrical appliance.
  - The addition of extra electrical appliances, such as high-power audio systems, light fixtures, etc., may overload and overheat the wiring harness and increase the risk of fire. Improper refitting of electrical appliances or wiring may cause a fire due to contact resistance and abnormal heating.
  - Fuses or other replacement wires in excess of relevant electrical rating are strictly prohibited.
- Select a proper parking location.
  - When the vehicle is parked, especially in summer, do check whether there are any flammables such as dry grasses, dead woods, leaves or wheat straws under the vehicle. If any, a fire may be caused as the temperature of the exhaust system components rises after a long-term drive.
  - When the vehicle is running, avoid driving on the road sections piled up with flammables such as dry leaves, wheat straws and grasses, or immediately stop the vehicle to check whether any flammables are carried along after passing such road sections. When parking the vehicle, try to avoid sun exposure.
- Disconnect the negative cable of the low-voltage battery when the vehicle is being serviced or repaired.
- Keep a lightweight fire extinguisher in the vehicle and know how to use it.
  - In order to ensure vehicle safety, a fire extinguisher should be equipped in the vehicle, and be checked and replaced regularly. Also, you should familiarize yourself with use of the fire extinguisher and be prepared for any accidents.
- In the event of a fire in the vehicle, take effective measures in a timely and calm manner to minimize any losses.
  - Fires typically show initial warning signs, such as abnormal noises and odors in the vehicle body. When abnormal conditions are found, turn off and stop the vehicle immediately. Try to put out the fire if possible.
  - Call the fire alarm in time, and also dial the insurance company's reporting number and ask the company to come to the fire site for handling.
- Find out the origin of the fire. In case of any smoke in the engine compartment, do not open the hood immediately (because this aggravates the combustion and spread of the fire due to air ingress. There is limited comburent in the engine compartment, so the hood shall be kept closed to control the flames, which is conducive to firefighting). Point the on-board fire extinguisher at the ignition point from the hood gap to put the fire out, or seek help from the passing cars. If you can borrow more fire extinguishers, open the hood to put it out when you cannot see any flame from outside
- If the fire brigade is involved, ask for a duty performance certificate and a description of fire cause.
- After occurrence of the accident, contact the insurance company for

post-event handling in a timely manner.

### REMINDER

- In order to mitigate losses in the event of an accident, the purchase of commercial insurance (fire loss, theft, etc.) is recommended.

## Snow Chains

- Snow chains are only for emergencies or areas where they are permitted by laws.
- Snow chains should be installed on rear wheels, and the front wheels should not be equipped with snow chains. Be careful when driving the vehicle installed with snow chains on snow-covered roads. Use thin snow chains. Some snow chains may damage tires, wheels, and the vehicle body. The recommended snow chains are no larger than 10 mm in thickness or diameter, which provides enough space between tires and other parts in the hubcap.
- Read the component assembly drawings and other instructions provided by the snow chain manufacturer carefully.
- Before purchasing and installing snow chains, consult a BYD authorized dealer or service provider where your vehicle was purchased.
- In order to minimize wear of tires and snow chains, do not travel with snow chains on roads without snow.

### CAUTION

- After snow chains were installed, it is recommended that the driving speed must not exceed 30 km/h and the speed limit

### CAUTION

- specified by the snow chain manufacturer.
- Drive carefully, paying attention to bumps, potholes, and sharp turns that can cause the vehicle to bounce.
- For vehicles with snow chains, avoid sharp turns or braking with locked wheels, and slow down the vehicle before entering a curve to avoid accidents.
- Install the chains symmetrically on the left and right sides and remove them immediately after driving out of snowy roads.
- If the snow chain gives an abnormal sound, please stop the vehicle immediately to check whether the suspension, body or brake, brake line and other parts are normal, and make sure there is no interference with the snow chain.
- When installing the snow chain, park the vehicle on a flat surface away from traffic, turn on the hazard warning lights, and place a warning triangle at the rear of the vehicle.
- Before installing snow chains, switch off the engine and engage the parking brake. Do not install snow chains with insufficient tire pressure.
- When using tire chains, be careful not to damage the aluminum rims.

# Starting and Driving

## Starting the Vehicle

In normal cases, start the vehicle as below:

- Carry a valid smart key with you, depress the brake pedal ① and press the "START/STOP" button ② at the same time, and then the OK indicator on the instrument cluster illuminates, indicating that the vehicle is ready for driving.
- Shift to "D" or "R" position, and then the electrical parking brake will be released automatically. Do not start driving until hearing a motor release sound from the electronic parking brake system.



The vehicle cannot be powered on when:

- The vehicle cannot be powered on when:
  - After you press the "START" button, if the smart key warning light turns on, a beep sounds, and the message "No key detected" is displayed on the instrument cluster, the key may not be in the vehicle or cannot be detected due to interference.
  - The key is somewhere unsuitable for detection, such as on the floor, in

the cup holder, pickup bed, or right storage compartment.

- Pressing the "START" button may not enable the start function due to:
  - If the electronic smart key does not work, the smart key system warning light flashes and the message "Low key battery" is displayed on the instrument cluster, the battery of the key may be exhausted. Replace the electronic smart key battery as soon as possible with reference to **P212**.
  - The engine is started repeatedly in a short time. Wait for 10 seconds and start the vehicle again.
  - Except for causes mentioned above, the smart access and start system also fails to work normally under some conditions due to different service environments. See **P59** for relevant details.

Starting the vehicle in emergencies:

- Engage the parking brake firmly.
- Turn off all unnecessary lights and accessories.
- Shift to "P" or "N".
- The power mode is "OFF".
- The electronic smart key is in the vehicle.
- Press and hold the "START/STOP" button for more than 15 seconds to start the vehicle.

### CAUTION

Do not start the vehicle for more than 20 seconds at a time, or the wiring system will overheat.

Remote Start

- Press and hold the remote start/stop button on the electronic smart key to

start the vehicle. After it is started, turn signals flash three times.

- If there is no valid operation within 10 minutes after remote start, the vehicle stops and powers off, and turn signals flash twice.
- After the successful start, press and hold the start/stop button on the smart key to shut down the engine and power off the vehicle, and turn signals flash twice.



## Driving

- During driving, energy is recovered by regenerative brake when the vehicle decelerates. For higher efficiency, do not accelerate or decelerate the vehicle unnecessarily.
- The function can be set in relevant setting interface on the infotainment touchscreen. Users can select the corresponding energy regeneration mode according to driving habits.
  - Standard: When the accelerator pedal is released, the motor controller recovers energy in the standard level, and the vehicle deceleration is in the standard level.
  - High: When the accelerator pedal is released, the motor controller recovers more energy, and the vehicle deceleration is high.
- You can select the regeneration intensity based on the deceleration

sense when releasing the accelerator pedal. Different deceleration senses deliver different driving experiences.

- The set regenerative braking intensity will be memorized. When the vehicle is powered off and then on, the regenerative braking mode set last time will be maintained.

### REMINDER

- Do not set the regeneration intensity when driving the vehicle in high speed, as the driver may be distracted. This may obstruct the control of the vehicle, resulting in accidents.
- During driving, if the vehicle is switched from ECO mode to SPORT mode, it will immediately supply more power than before to meet the driver's needs. Please pay attention to driving safety.
- When the vehicle is in the HEV-ECO or HEV-NORMAL mode, according to the high-voltage battery SOC and the vehicle speed, the engine may start and stop frequently, which is a normal economic operation mode.
- In HEV mode, the engine automatically starts and stops as needed to charge the battery or provide additional power. In some conditions, the engine may start, or stop if it has started.
- Vehicle power is lower at low battery SOC than that at high battery SOC.

### CAUTION

- Higher battery SOC can ensure sufficient discharge power of the high-voltage battery, so that the engine can work normally and a better acceleration experience can be obtained.



## CAUTION

- Battery fault, generator fault, and engine fault may affect the power output.

### Safety Check Before Driving

It is advisable to carry out a safety check before driving a long distance, which ensures your driving safety and enhances your driving experience. The vehicle can also be taken to a BYD authorized dealer or service provider for inspection.

#### Exterior

- Tires: Check tire pressure and carefully inspect tires for any cut, damage, foreign material, anomaly, and excessive wear.
- Lug nuts: Check whether nuts are loose or missing.
- Leaks: After the vehicle has been stationary for some time, check for fluid deposits beneath it. These may indicate a leak of fuel, engine oil, coolant or other liquids. (It is, however, normal for a small pool of water to form, caused by the air conditioning system.)
- Lighting: Make sure headlights, position lights, turn signals and all other lights are working normally. Check headlight intensity.

#### Interior

- Seat belts: Check whether seat belts can be properly fastened. Verify that seat belts are not worn or scratched.
- Instrument cluster: Particularly, verify that maintenance indicator, instrument cluster lighting, and defroster work properly.
- Brake pedal: Verify that there is enough space for the brake pedal to work.

- Low-voltage battery and cables: Check connectors for any corrosion or looseness and any cracks in the low-voltage battery housing.

### In the engine compartment

- Spare fuses: Verify that spare fuses of all rated charges in the fuse box are available.
- Coolant level: Verify that coolant level is correct.
- Fuel pipe: Check the pipe for any fuel leakage and loose connections.

### Check after starting

- Exhaust system: Listen for leakage. In case any leakage is found, have it repaired immediately.
- Engine oil level: After the engine is warmed up, stop the it for 10 minutes, park the vehicle on a flat ground, and check the oil level.
- Instrument cluster: Confirm that the maintenance indicator and the speedometer work normally.
- Brakes: In a safe area, drive the vehicle straight, hold the steering wheel tightly, decelerate and apply the brake. Verify that the vehicle maintains a straight direction.
- Other abnormalities: Check for loose parts, leaks, and unusual noises.

### Preparations Before Driving

- Check the surroundings before getting into the vehicle.
- Adjust seat position, seatback angle, cushion height, headrest height, and the steering wheel angle and height.
- Adjust the interior rearview mirror and side mirrors.
- Close all doors.



- Fasten the seat belts.

### Kick-Down Function\*

- During driving, when the vehicle is going uphill or it is necessary to accelerate rapidly or press the accelerator pedal deeply, almost fully pressing the accelerator pedal increases the pedal resistance and triggers this function, so that the engine speed increases to provide greater power for the vehicle.
- Higher battery SOC can ensure sufficient discharge power of the high-voltage battery, so that the engine can work normally and a better acceleration experience can be obtained.
- Battery fault, generator fault, and engine fault may affect the Kick-Down power output.
- Frequent triggering of the Kick-Down function will cause the battery level of the vehicle to drop rapidly.

## Driving Mode

The driving modes include Snow, Muddy, Sand, and Mountain modes\*. You can switch between them by turning the Terrain scroll button on the right side of the steering wheel.

### Snow mode

- Snow mode is recommended for roads with a firm roadbed and a layer of loose and slippery materials such as grass, snow, ice, or gravel. The vehicle improves the four-wheel grip by optimizing its towing, driving, and manipulation features in slippery conditions.

### WARNING

- Do not park on very steep slopes.

### CAUTION

- The adhesion coefficient of snow-covered roads is low, so drive with caution and slow down for corners.

### Muddy mode

- Muddy mode is recommended for roads that are muddy, deeply rutted, soft and uneven, or where the vehicle is prone to skidding and getting stuck. The vehicle optimizes the driving force output and the ESC parameters for better passing through these roads.

### WARNING

- Never drive in this mode on paved roads.
- Do not park on very steep slopes.

### CAUTION

- Drive at a constant speed and avoid stopping midway in the mud.
- Before driving through a mud pit, get off the vehicle to check the depth of the pit and whether there are any hidden obstacles.
- Be sure to keep a sufficient safe distance from the vehicles ahead because the vehicle braking distance increases when driving on wet or muddy roads.
- When driving on mud, be careful of sudden changes in speed or direction.

 **CAUTION**

- Clean your vehicle after driving through the mud. Otherwise, the excessive mud in the vehicle will lead to vehicle imbalance, causing damage.

**Sand mode**

- Sand mode is recommended for roads that are soft, dry, or easily pressed by wheels (e.g., sand and deep snow). The vehicle optimizes the driving force and saves battery power for better running on the sand.

 **WARNING**

- Never drive in this mode on paved roads.

 **CAUTION**

- For desert driving, it is recommended to adjust the tire pressure to 120 kpa (1.2 bar).
- In sand mode, the vehicle automatically sets a higher target SOC. Make sure the vehicle is fully charged before driving.
- When parking on a slope, adjust the front of the vehicle to face downhill to reduce the possibility of rollover.
- When driving on sand, keep as many wheels as possible running on the firmest surface.
- After driving over sandy roads, check the braking system and ensure that it is normal. Clean the debris such as sand and dirt at the bottom of the vehicle to prevent vehicle failure.

 **CAUTION**

- After each desert off-road trip, it is recommended to check the following parts in time and maintain the vehicle or send it for repair as needed:
  - Engine oil filter element
  - Air conditioner filter
  - Electric fan
  - Tires
  - Lighting
  - Brake pedal, brake pad, and brake disc
  - Charge port door and fuel door
  - Air filter element
  - Door hinges
  - Locks, latches, and interior buttons
  - Supercharger pressure end lines and impellers

**Mountain mode\***

- Mountain mode is recommended for roads with mixed soil and stones or potholes, such as rugged mountain roads, hills, gravel roads, etc. The vehicle improves the off-road capability by intelligently adjusting the driving force output.

 **WARNING**

- Never drive in this mode on paved roads.
- Drive uphill and downhill in a straight line to prevent lateral skidding and rollover.
- Do not park on very steep slopes.

 **WARNING**

- Pressing the accelerator pedal too deeply may cause tires to slip, spin, or lose traction, resulting in loss of vehicle control.

## Driving with Low Fuel Consumption

Fuel consumption and driving range are related to many factors. Taking some corresponding measures, such as good driving style and regular maintenance, cannot only improve the driving range and reduce fuel consumption, but also be conducive to environmental protection.

- Drive in "ECO" mode as much as possible
- Keep the vehicle in good condition
  - Carry out maintenance: Regular maintenance of the vehicle ensures a longer service life and the best economy.
  - Check the tire pressure regularly: Check the tire pressure at least twice a month, check the tire pressure before long-distance driving, and calibrate the tire pressure if necessary (Excessively low tire pressure increases rolling resistance, resulting in greater power and fuel consumption and tire wear).
- Drive at the speed in "ECO" mode as much as possible.
  - Drive at the speed in "ECO" mode can effectively improve driving range and reduce fuel consumption. Whether the speed is too high or too low, it consumes more fuel. On the premise of ensuring safety, try to keep your vehicle running at the speed in "ECO" mode.
- Predictive driving
  - On the premise of ensuring driving safety:
    - Avoid unnecessary rapid acceleration and braking;
    - Always keep a proper distance from the vehicle ahead on:
      - When the traffic light turns red, release the accelerator pedal to allow the vehicle to skid with inertia;
      - Keep a constant speed.
  - Use the energy recovery system rationally
    - On the premise of ensuring safety, select the appropriate braking intensity under different road conditions to match the driving state of the vehicle. To make full use of the energy recovery system, step on the brake as lightly as possible to slow down and avoid sudden deceleration.
  - Reduce unnecessary items in the vehicle
    - Additional weight increases energy consumption.
  - Proper use of A/C system
    - Heating and cooling are energy-consuming, which will significantly reduce the driving range and increase fuel consumption. Reasonable use of A/C system can effectively reduce power and fuel consumption.
  - Turn off functions that are temporarily not needed
    - Interior heating consumes a large amount of electrical energy (e.g. seat heating\*) and should be switched off when not required.

## ! REMINDER

- During the break-in period, do not drive under heavy load, and the vehicle speed shall not exceed its maximum speed.
- It is recommended to press the accelerator pedal lightly for acceleration to reduce damage to the vehicle caused by hard press.

## Gear Shift Controls

- The gear position of the gear actuator is marked on the gearshift lever as shown.
- "P": Park, press this button to park the vehicle and the parking indicator will light up. Press the brake pedal to start the vehicle, you may shift from "P" to another position.



## ! CAUTION

- To prevent damage, press the "P" button only after the vehicle has completely stopped.
- "R": Reverse, used only when the vehicle has come to a complete stop.
- "N": Neutral, used for temporary stop. Under all circumstances, always shift to "P" before the driver gets out.

- In Park, to shift into Neutral, press the brake pedal, move the shift lever forward to the first gear, and hold it for 0.5 second.
- In Drive, to shift into Neutral, move the shift lever forward to the first gear and hold it for 0.5 second.
- In Reverse, to shift into Neutral, move the shift lever backward to the first gear and hold it for 0.5 second.
- "D": Drive. Shift to "D" to drive the vehicle normally.
- If the shift is successful, the lever returns to its middle position after it is released.
- Turn the ignition on before shifting into "D".
- Shifting out of Park or into Drive requires pressing the brake pedal. For details, see the prompt message on the instrument cluster.
- To prevent unintended vehicle movement, press the "P" button once the vehicle has stopped completely. The electronic parking brake (EPB) is automatically applied and the EPB indicator lights up.

## ! CAUTION

- If the EPB indicator does not come on after shifting into P, enable the EPB on the shortcut menu or go to  → **ADAS** → **Safety Assist** on the infotainment touchscreen. In this case, contact a BYD authorized dealer or service provider.

## The P Parking Switch

Press this button to park the vehicle and the button lights up with the vehicle shifted into "P".

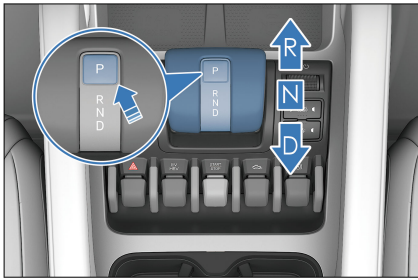

### Electricity generation in "P"

When the vehicle SOC is low, press the "P" button and shift into Park, and the engine drives the generator to charge the high-voltage battery. During electricity generation, the engine speed is different from the normal idle speed, and it automatically exits after generating a certain amount of electricity. If high-power generation or more electricity is needed, step on the accelerator pedal and stop after generating more electricity.

- Activating conditions for electricity generation in "P":
  - The high-voltage battery SOC is very low.
  - The high-voltage battery temperature is moderate.
  - The powertrain has no limitations or fault prompts.
- Deactivating conditions for electricity generation in "P":
  - A certain amount of electricity is generated.
  - The high-voltage battery temperature is very high or very low.
  - The powertrain has limitations or fault prompts.
  - The engine or clutch fails.

### Shutting the engine down in "P"

When the vehicle SOC is high, the engine is automatically shut down after "P" is

engaged, and the power consumption of electric equipment is supplied by the high-voltage battery, which can reduce fuel consumption and noise in the vehicle in idle condition.

- Activating conditions for shutting the engine down in "P":
  - The high-voltage battery SOC is high.
  - The high-voltage battery temperature is moderate.
  - The powertrain has no limitations or fault prompts.
- Deactivating conditions for shutting the engine down in "P":
  - The high-voltage battery temperature is very high or very low.
  - The high-voltage battery is low.
  - The outside temperature is very low, and there is a need for heating or defrosting.
  - The powertrain has limitations or fault prompts.

### WARNING

- If the engine or motor is shut down, do not allow the vehicle to move after it has been shifted to "N", to avoid accidents due to insufficient braking force.
- When the engine or motor is running and the vehicle is in the "R"/"D" gear, be sure to stop the vehicle by depressing the brake pedal, as the actuator can still transmit force and the vehicle can travel slowly even in its idle condition.
- If you want to shift a gear while driving forward, do not step on the accelerator pedal to prevent accidents.

### **WARNING**

- In order to prevent accidents, never shift to "R" or press the "P" button while the vehicle is moving.
- Never coast downhill in "N", especially if the engine or motor is not running.



## Electronic Parking Brake (EPB)

Be sure to engage the Electronic Parking Brake (EPB) every time before parking and leaving the vehicle.

### Engaging EPB Manually

- When the vehicle is not in "P" and EPB is released, press the brake pedal and engage electronic parking brake (EPB) on shortcut menu or infotainment touchscreen →  → **ADAS** → **Safety Assist**. Then, EPB applies appropriate parking force, and the indicator on the instrument cluster flashes and then is steady on, indicating that EPB is engaged. In addition, a text prompt "EPB activated" is displayed.

### **CAUTION**



- When  flashes, EPB is working. If the vehicle is on a slope, do not release the brake pedal until  is steady on. Otherwise the vehicle may move down.

### Engaging EPB Automatically

#### Switching the ignition off

- When the ignition is switched off, EPB engages automatically and  lights up on the instrument cluster.

### Shifting into Park

- Press the brake pedal to stop the vehicle steadily and shift into Park. EPB is engaged automatically. Do not release the brake pedal until  on the instrument cluster stops flashing and becomes steady on and the "EPB ON" message is displayed.
- Press the brake pedal to bring the vehicle to a complete stop. If the driver's door is opened while the gear is in Drive or Reverse, the vehicle will be automatically shifted to Park and the EPB will be engaged. Do not release the brake pedal until the indicator  on the instrument cluster stops flashing and becomes steady on and the "EPB ON" message is displayed.

### **WARNING**

- Refrain from excessively utilizing the automatic EPB engagement triggered by opening the driver's door, as it may result in the EPB not engaging properly or insufficient clamping force, leading to rollaway risks. For safety, make sure that the vehicle is shifted into Park and the EPB is engaged before getting off.

### **CAUTION**

- Do not release the brake pedal early in the process, especially when the vehicle is stopped on a slope; otherwise the vehicle may slip back.
- Engaging EPB automatically with the ignition off is designed



### CAUTION

to improve the vehicle safety. Excessive reliance or frequent use of the function may lead to low SOC of low-voltage battery, resulting in the risk of vehicle slipping due to insufficient EPB clamping force. For safety, make sure that the vehicle is shifted into Park and the EPB is engaged before getting off.

### Automatic EPB Release upon Vehicle Start

Releasing by shifting gear:

- With the vehicle parked, start the vehicle, press and hold the brake pedal, and shift from "P" or "N" into a driving gear such as "D" or "R". EPB is released automatically, the indicator goes off, and the "EPB released" message is displayed.



### CAUTION

- Be sure to always press and hold the brake pedal when shifting gears. Release the pedal only after the intended gear is displayed on the instrument cluster.
- The EPB system conducts power-up self-check within several seconds after the vehicle is started. In this process, the system does not respond to any function.

Releasing by pressing the accelerator pedal:

- When the vehicle has been started and the gear is in a driving gear such as "D" or "R", engage EPB on the infotainment touchscreen, then simply press the accelerator pedal slowly to a certain degree. EPB is released automatically

and  turns off with the message "EPB released" displayed.

### Emergency Braking When Brake Pedal Fails

- When the vehicle is in motion and ESC system works normally, controlled deceleration for parking brake (CDP) can be used for emergency braking if braking fails or is blocked.
  - Press the "P" button continuously for over two seconds to force the vehicle to brake. Pressing the brake pedal simultaneously allows the vehicle to decelerate faster.
  - You can release the "P" button to stop braking.
  - After the vehicle stops, EPB remains engaged and must be released again before you can start the vehicle.



### CAUTION

- When CDP is activated, if the accelerator pedal is pressed more deeply, CDP will exit and the vehicle will keep running.



### WARNING

- For safety considerations, refrain from using the "P" button for emergency braking in normal driving. If the brake pedal fails or is blocked, the driver must keep the vehicle under control when using the emergency braking function.
  - As the EPB cannot go beyond the physical limit of road adhesion, activating the emergency brake function may result in vehicle drift, sideslip, or deflection when the vehicle passes through bends or dangerous/heavy-traffic road

## **WARNING**

sections, or when the vehicle is driven under severe weather conditions. Be careful to avoid any accident.

### **EPB Trailer Mode**

The EPB trailer mode is mainly set for the automatical EPB engagement function with the ignition off. When the vehicle needs to be powered off for being towed, or when it malfunctions, you can switch on the mode to exit parking with EPB. If EPB cannot be released, contact a BYD authorized dealer or service provider immediately.

- Tap  → **Service** → **Overhaul** → **EPB Trailer Mode** to enable the function.
- EPB trailer mode activation conditions (all must be met):
  - The vehicle is in Park.
  - Press the brake pedal.
  - The charging connector is not connected, and the vehicle is not being charged.

## **CAUTION**



- When the activating conditions of EPB trailer mode are not met, a corresponding prompt message displays on the infotainment touchscreen.
- After activating the EPB trailer mode, the corresponding screen always displays on the infotainment touchscreen unless you tap to exit the EPB trailer mode.
- When the vehicle is on a slope and you need to enable the EPB trailer

## **CAUTION**

mode, do not release the brake pedal during the process to avoid vehicle slipping.

- EPB trailer mode exiting conditions (one of them is enough):
  - Disable the EPB trailer mode on the infotainment touchscreen.
  - Press the "P" button.
  - Charging starts after the charging connector is connected.

### **EPB System Indicator**

- When the vehicle is powered on, if the EPB is engaged,  is solid on on the instrument cluster.
- When the vehicle is powered off, if the EPB is engaged,  on the instrument cluster turns on and then turns off in several seconds.
- When the vehicle is powered on, the EPB system starts self-check.  turns on and then off in several seconds on the instrument cluster. If it does not, the EPB or braking system may be faulty. It is recommended to contact a BYD authorized dealer or service provider for inspection immediately.

### **EPB Operating Sound**

- EPB motor noises can be heard while the EPB is being engaged or released.
- If there is a burning smell or unusual noises after emergency braking is activated, contact a BYD authorized dealer or service provider immediately.



### WARNING

- To prevent skidding, shift to "P" and make sure the EPB is on before leaving the vehicle.
- To prevent a serious accident, never allow any passenger in the vehicle to operate the EPB switch when the vehicle is running.
- When the EPB switch is pulled or released, the brake pedal must be pressed to prevent the vehicle from moving, and the subsequent locking of the gearshift that occurs because EPB cannot provide a sufficient parking force.

## Automatic Vehicle Hold (AVH)



Automatic vehicle hold (AVH): The automatic vehicle hold (AVH) is activated automatically when the moving vehicle needs to be stationary for longer periods of time, such as in traffic jams on a slope or waiting at traffic lights.

### AVH standby

- When the ignition is on, press the AVH switch to enable AVH.  is displayed on the instrument cluster.
- Press the AVH switch again to disable AVH.





### AVH activated

- When the AVH standby indicator  is solid on, press and hold the brake pedal until the vehicle stops (vehicle speed reduces to zero) to activate AVH. At this time, the vehicle is in AVH state with  displayed on the instrument cluster.

### CAUTION

- For AVH to be activated, all of the follow conditions must be met:
  - The driver's seat belt is fastened and the doors are closed.
  - Intelligent power braking system and electronic park brake (EPB) systems are normal.
- Pressing the accelerator pedal, shifting into Park, powering off the vehicle or engaging the EPB manually can make AVH exit to the standby status.
- AVH has a memory function, which will keep the state of the last power off when it is powered on again.

### AVH running

- The AVH function runs normally when it is activated, brake lights and the high-mount brake light are on, and the AVH indicator  is solid on on the instrument cluster.
- The AVH function exits to the standby mode after the vehicle stops for 10 minutes, with the AVH standby indicator  lighting up and gear shifted into Park automatically.
- To activate AVH function, shift into Drive to enable the vehicle to move normally, and then press and hold the brake pedal until the vehicle stops (vehicle speed reduces to zero).

## AVH exits

- When the AVH function runs normally, AVH exits and the gear is shifted into Park from Drive automatically when the driver performs the followings:
  - Open the driver's door.
  - Unlock the driver's seat belt.
  - The gear is in Drive when the vehicle stops, and EPB is enabled.
  - Press the AVH switch to disable AVH when releasing the brake pedal.

## AVH suppressed

- When you shift into Reverse, AVH goes into slow-moving condition. When the vehicle is reversing (in Reverse) or traveling (shift into Drive from Reverse) at a low speed, AVH cannot be activated but stays on standby to facilitate low-speed vehicle motion.
- To exit slow-moving mode, push the AVH switch or drive at a speed above 10 km/h. The AVH function is on standby and can be activated normally.

## Driving Precautions

- Slow down when driving against strong winds to control the vehicle.
- When driving on gravel roads, drive slowly and keep the correct angle as far as possible. To prevent tire damage, do not drive over sharp-edged objects or other road obstacles. Or it will severely damage the tires.
- Slow down on bumpy or uneven roads. Otherwise, the impact may seriously damage wheels.
- Washing the vehicle or driving through deep water may wet the brake. For checking wet brakes, ensure that the surroundings are safe and then press the brake pedal gently. If the braking

force is not normal, the brake may be wet and needs to be dried. Drive carefully and press the brake pedal gently while engaging the EPB.

- If the wheels are trapped, it is recommended to switch to sand mode for getting out. However, the vehicle may not be able to get out of trouble if the vehicle battery is low, all wheels are slipping, the EV function is limited, or the ESC system malfunctions.

### **WARNING**

- The driver shall ensure the riding safety of all passengers in the vehicle, guide them to correctly use vehicle features, and prevent children and other passengers from operating control switches such as window switches in a wrong way.
- To avoid traffic accidents and life-threatening injuries, make sure no occupants stick their heads or hands out of any window when the vehicle is running. Stay vigilant, especially when any child is in the vehicle.
- Be careful when accelerating, shifting gears, or braking on slippery roads. Quick acceleration or sudden braking will cause the vehicle to skid or deviate.
- Do not leave the vehicle when the drive motor is running.

### **CAUTION**

- Do not press and hold the START/STOP button for over three seconds while driving, as this will cut off the power output and activate the emergency power-off. Therefore, unless it is absolutely necessary (such as failure to park



## CAUTION

the vehicle properly), do not stop the vehicle in this way, so as to avoid vehicle collisions or serious personal injuries.

- If the emergency power-off is activated, the vehicle will be switched from "OK" to "ON", and the vehicle will lose power and cannot run normally. At this time, it is recommended that you turn on the hazard warning light.
- Emergency power-off during driving will not cause the steering system and brake system to be out of control, but the steering wheel and brake will lose power assistance. At this time, it is more laborious to turn the steering wheel and press the brake pedal. Therefore, before the emergency power-off, the vehicle should be slowed down as much as possible, or parked on the roadside as far as possible on the premise of ensuring safety.
- Before driving, make sure that EPB is fully released and that the EPB indicator light is off.
- Under normal driving conditions, do not press the accelerator pedal and brake pedal at the same time, otherwise the power output may be limited.
- If there is no need to brake, do not put your foot on the brake pedal for a long time to avoid system overheating, wear and power waste.
- Slow down when driving down long steep slopes, and avoid pressing the brake pedal too frequently to prevent disc



## CAUTION

overheating, which affects normal brake operations.

- Avoid driving through flooded areas as much as possible on wet roads.
- Large amounts of water entering the engine compartment can cause damage to the engine power system and electrical components.

## Winter Driving Precautions

- Make sure the coolant is freeze-proof.
  - Use coolant of the same type as the one used originally. Fill up proper coolant into the cooling system based on the ambient temperature.
  - Improper coolant will damage the cooling system.
- Check batteries and cable conditions.
  - The low-voltage battery's capacity is lower in cold weather, so they must be fully charged for startup in winter.
- Confirm that the viscosity of the oil is suitable for winter driving.
- Avoid the door lock being frozen by ice and snow.
  - Spray some deicing agent or glycerin in the lock hole to prevent freezing.
- Use anti-freeze washer fluid.
  - These can be found in BYD authorized dealers or service providers and all auto parts stores.
  - The water and anti-freeze ratio must conform to manufacturer instructions.

## CAUTION



- Use special washer fluid to prevent paint damage.
- Prevent ice and snow from going under the fender.
  - Steering is difficult with ice or snow accumulating under the fenders. When driving in cold weather, stop from time to time and check for snow and ice under the fenders.
- It is recommended to carry emergency tools or items for different road conditions.
  - It is advisable to have snow chains, window scrapers, bags of sand and salt, flashing signals, a shovel and connecting cables in the vehicle.

# Driver Assistance

## Adaptive Cruise Control (ACC)\*

- The Adaptive Cruise Control(ACC) system, an extension of the traditional cruise control, uses front mmWave radars and a multi-purpose camera to detect the relative distance and speed of the vehicle ahead, so as to control vehicle speed accordingly for automatic cruise control. The system switches between regular cruise control and ACC depending on whether there is a vehicle ahead.
- Cruise speed and time interval from the vehicle ahead can be set by using the cruise buttons. You can set the cruise control speed within the 30–130 km/h (20–80mph) range, or set a fixed distance from the vehicle ahead to cruise at speeds between 0 km/h and 130 km/h (0–80mph).

## Status Description

- ACC standby:
  - Once enabled, the system is on standby by default and can be manually activated. If the vehicle does not meet activation conditions, it must be checked until such conditions are met. At this time,  (with a variable cruise speed value) is displayed on the instrument cluster.
- ACC activated:
  - The system is operational. It maintains the set speed or automatically adjusts the distance from the vehicle ahead. At this time,  (with a variable cruise speed value) is displayed on the instrument cluster.
- Over speed:
  - When you step the accelerator pedal while ACC is active, the vehicle responds to your acceleration action so that the ACC is temporarily deactivated until you release the pedal.
- ACC failure:
  - There has been a failure in the system. No operation can be performed, and the ACC failure indicator  lights up on the instrument cluster. Contact a BYD authorized dealer or service provider.

## ACC Activation Conditions

- The EPB is released.
- The vehicle is in Drive.
- The vehicle does not slide backwards.

- The trunk, hood, and all doors are closed.
- Driver seat belt is fastened.
- The ESC system is on, but not activated yet.
- Vehicle speed is not greater than 130 km/h (80 mph).
- Brake pedal is pressed or AVH is activated at speed 0, or brake pedal is not pressed at speeds above 0.
- There is no vehicle network communication failure prompt on the instrument cluster.
- The AEB function is not activated.

## How to Use

### ACC activation/exit button

- Press ④ button to activate or exit ACC (with ICC switch on the infotainment touchscreen off, this button is ACC switch). (By default, ACC activation by pressing button ④ sets the current speed as the cruise speed. If the current speed is below 30 km/h, the cruise speed is set to 30 km/h.)

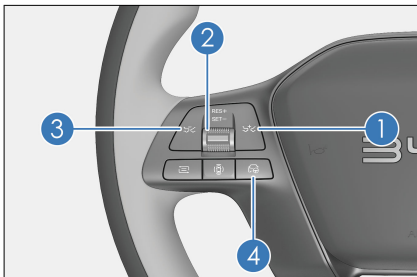

### Resetting ACC

- When the ACC system is on standby within the same ignition cycle, the system memorizes the last speed setting. Push up the lever ② to revert to the stored speed prior to exiting the cruise system.

### Increasing/Decreasing target speed

- When ACC is active, set the vehicle to a speed within the 30~130 km/h range by moving the lever ②. Toggle the rocker switch ② up/down to increase/decrease the vehicle target speed by 5 km/h. Press and hold the rocker switch up/down to continuously increase/decrease the vehicle target speed by 1 km/h.

### Exiting ACC

- While ACC is being activated, pressing the button ④ for a second time or depressing the brake pedal makes the ACC system exit activation and go on standby.

### Setting vehicle distance

- The driver must select a safe vehicle distance.
- The system adjusts vehicle speed to keep a suitable distance from the vehicle ahead on the same lane. Pressing buttons ① and ③ on the steering wheel adjusts vehicle distance to any of the four available levels. At each level, vehicle distance is in direct proportion to vehicle speed. The faster the speed, the longer the distance.

### Increasing/Decreasing speed with ACC active

- When ACC is activated, you can press the accelerator pedal to reach the set target cruise speed in advance. The system then enters over speed mode. At the target cruise speed, if you accelerate without performing any other operations, the vehicle accelerates and then returns to the target cruise speed after the accelerator pedal is released. If you press the brake pedal to slow down the vehicle speed continuously, ACC goes into standby mode. After the brake is released, ACC needs to be reactivated by pressing the button.

## Follow-to-stop/start

- Controlled by ACC, the vehicle can stop when the vehicle ahead stops in normal driving conditions and resume driving automatically following the vehicle ahead if the stop is less than 30 seconds.
- If the vehicle stops for 30 seconds to three minutes, press the accelerator pedal or push up the lever ② to reactivate ACC.

## System Limitations

- The front mmWave radars are installed in the front of the vehicle. Blockage of its detection area by contaminants can disturb the intended function. In particular, if the sensor is covered by snow completely, the ACC system exits and informs of this on the instrument cluster. System function will recover after blockage is removed and the vehicle is restarted or runs on normal roads for a while.
- Front mmWave radar sensors may have a transient function failure from limited detection if the vehicle runs under special conditions, such as circular ramps or tunnels, for an extended period. The function can be recovered by restarting the vehicle or driving on normal roads for a while.
- Reaching or leaving a curve may delay or disturb target selection. In such cases, the ACC vehicle may not brake as expected or may brake late.
- On roads with sharp curves, such as winding roads, the vehicle ahead may be out of ACC sensor detection for several seconds due to sensor vision limitations, possibly causing the ACC vehicle to accelerate automatically.
- Traffic flow and weather conditions, such as rain and fog, must be heeded for setting vehicle distance on the

ACC system. After the ACC system is properly set, the driver must be able to decelerate until the vehicle stops at any time.

- The ACC system may not be able to identify stationary or slow-moving objects (such as vehicles, toll booths, bicycles, and objects at the end of traffic) and pedestrians. This means a risk of collision and requires the driver to beware of the surroundings at all times.
- ACC system may fail to identify pedestrians or oncoming vehicles, resulting in driver assistance functions failure, such as braking failure or misidentification.
- The ACC may not provide sufficient braking force at speeds above 60 km/h or on slippery roads. The driver should be aware of the vehicle's surroundings and take control of the vehicle in time.
- Metal objects, such as rail or metal plates used in road construction, may interfere with front mmWave radars, making it malfunction.
- Performance of front mmWave radar sensors may be affected by vibration or collision. In this case, it is recommended to contact a BYD authorized dealer or service provider.
- In the case of heavy load, the function may fail, so the driver should keep control of vehicle at all times.

## Precautions

- ACC is not a safety system, obstacle detector or collision warning system, but a system that improves driving comfort. The driver must keep control of vehicle at all times and is responsible for the driving safety.
- ACC assists instead of replacing the role of the driver. The driver must keep

control of the vehicle at all times and is responsible for safe driving.

- For safety reasons, ACC cannot be activated with ESC disabled.
- The ACC is suitable for highways and roads in good conditions, rather than complex urban or meandering roads.
- It is the driver's responsibility to keep distance from the vehicle ahead.
- Vehicle control is transferred to the driver if the accelerator or brake pedal is pressed with ACC activated. As a result, the ACC system cannot keep a safe distance from the vehicle ahead.
- ACC may have no or slow responses to a vehicle ahead that brakes or stops suddenly, resulting in a risk of late braking. In such cases, there will be no take-over request.
- In some cases, such as when the vehicle ahead is going too slow, when lane change is too fast, when the vehicle ahead is quickly jammed at a close distance, or when the safe distance from the vehicle ahead is too short, there is no adequate time for the system to decrease the relative speed, so response has to come from the driver. The system may not give audio or visual warnings in every case.
- If ACC is activated with the vehicle stationary, the system identifies any stationary obstacle ahead and keeps the vehicle still to ensure a safe startup and prevent collision. However, this function cannot identify all the obstacles, so the driver must be alert to the front obstacles or other traffic participants.
- A short distance from an adjacent lane (or a vehicle on an adjacent lane that is too close to the ACC vehicle's lane) may trigger ACC to brake.
- Vehicles coming into the ACC vehicle's lane and within the detection range of its front mmWave radars are identified as target vehicles and prompt a response accordingly, which may lead to hard or late braking.
- Detection may be affected or delayed in some environments. If the radar cross section of the target (a bicycle, four-wheeler, or pedestrian, for example) is too small, the system may not be able to establish its distance, resulting in either late or no response to those vehicles. In such cases, vehicle speed must be controlled by the driver. In addition, detection may also be affected or delayed by noise or electromagnetic interference.
- ACC cannot target vehicles with too small contact ratio, so the driver must keep control of the vehicle.
- When the vehicle stops as it follows a vehicle ahead, in rare cases, the system does not recognize the end of the vehicle ahead but the lower end of the target (for example, the rear axle of a truck with a high chassis or a vehicle bumper). In such cases, the system cannot ensure proper stop distance, so the driver must stay alert and be ready to brake.
- Modifying the vehicle structure, such as lowering the chassis or changing the front license mounting plate, may affect the ACC system.
- Do not use the ACC system when visibility is poor, or when driving on slopes, winding roads, or wet roads (covered in ice/snow or flooded).
- When ACC is activated and the vehicle is stationary behind another vehicle, if the steering wheel is turned at a large angle, ACC will judge that the driver wants to change lanes and start, and ACC will exit.
- When AVH is activated (the vehicle is stationary), the activation of ACC will

cause the AVH to exit. Press the ICC (ACC)/RESET+ button again, and the vehicle will idle (ACC exits) or cruise (ACC does not exit).

- ACC cannot be activated in special driving modes like tow/snow/mud/sand/terrain (if equipped with these modes).
- Make sure to go to a BYD authorized dealer or service provider for professional calibration and checking of front mmWave radars or the front camera in any of the following situations:
  - The front mmWave radar, front bumper, or front windshield has been removed.
  - Wheel alignment has been carried out.
  - The vehicle has experienced a collision.
  - ACC system performance has degraded or the instrument cluster has prompted a system error.

### **WARNING**

- ACC serves as a driver assistance function only, so the driver is responsible for driving safety.
- Weather, road conditions, and other factors may affect normal use of ACC.
- Use ACC based on your needs, traffic, and road conditions.



## Intelligent Cruise Control (ICC)\*

- Intelligent Cruise Control(ICC) integrates ACC and lane centering control (LCC). It helps control the vehicle both longitudinally and

laterally at speeds between 0 and 130 km/h, easing the driving burden and enhancing driving safety and comfort.

- When the function is enabled, the driver must always hold the steering wheel and control the vehicle when necessary.
- Longitudinal assistance, driven by the ACC system, keeps the vehicle at a fixed speed or fixed driving intervals from the road user ahead.

### Status Description

- ICC standby:
  - The ICC system is on standby when ICC switch on the infotainment touchscreen is turned on and can be manually activated by pressing buttons on the steering wheel. If the vehicle does not meet activation conditions, the vehicle must be checked until such conditions are met. At this time,  is displayed on the instrument cluster.
- ICC activated:
  - The ICC system is operational. It maintains the set speed or automatically adjusts the distance from the vehicle ahead. At this time,  is displayed on the instrument cluster.
- ICC failure:
  - There has been a failure in the system. No operation can be performed, and  lights up on the instrument cluster. Contact a BYD authorized dealer or service provider.

### ICC Activation Conditions

- The EPB is released.
- The vehicle is in Drive.



- The vehicle does not slide backwards.
- The trunk, hood, and all doors are closed.
- Driver seat belt is fastened.
- The ESC system is on, but not activated yet.
- Vehicle speed is not greater than 130 km/h.
- Brake pedal is pressed or AVH is activated at speed 0, or brake pedal is not pressed at speeds above 0.
- There is no vehicle network communication failure prompt on the instrument cluster.
- The AEB function is not activated.
- Two-way lane lines are clear and the vehicle is at the center of the lane.

### How to Use

- Press ① on the steering wheel to activate (with ICC switch on the infotainment touchscreen on) or exit ICC. (By default, when the function is activated, the current speed is set as the cruise speed. If the current speed is below 30 km/h, the cruise speed is set to 30 km/h.)



- Enable or disable ICC in the infotainment touchscreen →  → **ADAS** → **Driving Assist**. This function can only be disabled on the infotainment touchscreen when the

vehicle is in "P". When the vehicle is started, the system defaults to previous settings.

### Precautions

- ICC integrates ACC and LCC. Therefore, ACC function precautions must be followed when using ICC (see the previous chapter for details).
- When ICC is turned on and activated at vehicle speeds between 0 km/h and 130 km/h:
  - If there is no lane lines ahead, transverse ICC control is suppressed and only ACC works. In that case, ICC working status indicator turns gray on the instrument cluster.
  - If lane lines ahead are clear and recognizable, transverse ICC control is activated automatically. In that case, ICC working status indicator shows activated status on the instrument cluster.
- ICC is a driving assistance system, not an automatic driving system. The driver should keep control of the vehicle at all times, and their hands should not leave the steering wheel for a long time. Otherwise, the system will exit after prompting the driver to take over the control.
- ICC can be affected by weather conditions, lighting and clarity of lane lines. Performance degrades significantly in situations such as backlighting, sunset, snow covered roads, and severely damaged roads.
- In the case of heavy load, the function may fail, so the driver should keep control of vehicle at all times.
- Do not use the ICC on winding roads with sharp turns (curves with large curvature), icy and slippery bends, or under weather conditions, such as dense fog, heavy rain and heavy snow,

liable to hinder the sensing operation of front mmWave radars or the front camera.

- ICC cannot be activated in special driving modes like tow/snow/mud/sand/terrain (if equipped with these modes).
- Situations where ICC cannot be used include:
  - The sensor is blocked.
  - The vehicle is running under severe weather conditions.
  - Active safety function is triggered.
  - Vehicle speed exceeds the specified range.
  - The road is too curvy.

### **WARNING**









- ICC serves as driver assistance only, so the driver must be fully responsible for driving safety.
- Weather, road conditions, and other factors may affect the normal operation of ICC.
- When the vehicle is passing through a sharp bend, ICC may be automatically disabled if its turning capacity is exceeded. The driver must always pay attention to road conditions and ICC states.
- Use ICC based on your needs, traffic, and road conditions.

## Traffic Sign Recognition (TSR)\*

The Traffic Sign Recognition (TSR) system identifies speed limit signs through the multi-purpose camera and map\*, displays such signs on the current road on the instrument cluster, and sends alarm

messages to the driver when vehicle speed exceeds the detected limit.

### How to Use

- Enable or disable TSR on the infotainment touchscreen →  → **ADAS** → **Safety Assist**. When the vehicle is started, the system defaults to previous settings.
- When the TSR system identifies the current traffic sign,  is displayed on the instrument cluster.
- When TSR cannot identify whether the recognized speed limit value applies to the lane,  is displayed.
- When the TSR system experiences reduced performance,  is displayed on the instrument cluster.
- When the TSR system has a reduced performance and cannot identify whether the recognized speed limit value applies to the lane,  is displayed on the instrument cluster.
- When the TSR system malfunctions,  is displayed on the instrument cluster.
- If you disable TSR manually by pressing buttons,  is displayed on the instrument cluster.
- When no available speed limit value is identified,  is displayed on the instrument cluster.

### Precautions

- The traffic sign recognition system can identify speed limit signs only, and will not control speed. The control over the vehicle always vests in the driver. Please drive properly.

- Weight limit signs not in standard size as per national regulations may mistakenly be identified as speed limit signs by TSR, which causes misidentification.
- If a speed limit sign is unclear or distorted, inclined, reflective, partly blocked or covered, the camera may be unable to recognize the sign completely or clearly.
- TSR performance depends on weather conditions, lighting, and sign visibility. The system may fail to or incorrectly identify the sign at night or sunset, in rainy, foggy, hazy, snowy or dusty environment, when light is coming from the back of the vehicle, or when there is a sudden change in lighting.
- In case the vehicle has been involved in a collision or the multi-purpose camera's sensor has been reassembled, go to a BYD authorized dealer or service provider for sensor calibration so as to avoid affecting system performance.

### WARNING

- TSR serves as a driver assistance function only, so the driver is responsible for driving safety.
- Influence of weather, road conditions, and other factors may cause TSR to fail or lead to late alarms.
- Use TSR based on your needs, traffic, and road conditions.

## Intelligent Speed Limit Control (ISLC)\*

- The intelligent speed limit control (ISLC) system integrates ACC and TSR. With the system enabled, if the vehicle travels faster than the detected

speed limit, a confirmation prompt is displayed asking whether to set cruise speed to that limit. After the driver confirms (by toggling down the ACC speed control lever ①), the system will automatically set cruise speed to the limit to prevent speeding.



- This function is accessible at the 30–130 km/h (20–80mph) speed range.

### How to Use

- Enable or disable ISLC in the infotainment touchscreen →  → ADAS → Safety Assist → Traffic Sign Recognition. The system is off by default.
- When the TSR system is disabled, the ISLC switch is grayed out and unusable. ISLC is turned off at this time. The ISLC switch will be usable after the TSR system is enabled again.
- ISLC can be activated provided that ACC is active.

### CAUTION

- ISLC integrates ACC and TSR. Therefore, ACC and TSR function precautions must be followed during use (see the previous chapters for details).
- ISLC is a driving assistance system, so the driver should keep control of vehicle at all times.

### CAUTION

- ISLC performance depends on weather conditions, lighting, and traffic sign visibility. The system may fail to or incorrectly identify the sign at night or sunset, in rainy, foggy, hazy, snowy or dusty environment, when light is coming from the back of the vehicle, or when there is a sudden change in lighting.







### WARNING

- ISLC serves as driver assistance only, so the driver is responsible for driving safety.
- Influence of weather, road conditions, and other factors may cause ISLC to fail or lead to late braking.
- Use ISLC based on your needs, traffic, and road conditions.

## Forward Collision Warning (FCW) & Automatic Emergency Braking (AEB)\*

Forward Collision Warning (FCW) and Automatic Emergency Braking (AEB) detect vehicles and pedestrians ahead by using front mmWave radars and the multi-purpose camera. When detecting a risk of collision, the system gives audio and visual alarms to alert the driver, and improves the potential braking pressure for better response timing. If detecting increased risk of collision, the system automatically applies braking pressure to assist in collision avoidance or impact reduction.

### How to Use

- To enable or disable FCW and AEB, go to the infotainment touchscreen →  → ADAS → Safety Assist.
- FCW gives alarms in forms of audio, text, and intermittent braking.
- When FCW is activated,  or  flashes, depending on the level of emergency, and a prompt message is displayed on the instrument cluster.
- When AEB is triggered,  and a prompt message are displayed on the instrument cluster.
- In the event of malfunction,  is displayed on the instrument cluster.
- If you disable AEB manually by pressing buttons,  is displayed.

### FCW Activation Conditions

All the following conditions must be met:

- This function has been turned on in **Vehicle**.
- Vehicle speed is within the 16–150km/h range.
- The vehicle is in Drive.
- The vehicle does not slide backwards.

### AEB Activation Conditions

All the following conditions must be met:

- This function has been turned on in **Vehicle**.
- Vehicle speed is within the 4–150 km/h range.
- The EPB is released.

- The vehicle is in Drive.
- The vehicle does not slide backwards.
- The trunk, hood, and all doors are closed.
- Driver seat belt is fastened.
- The ESC system is on, but not activated yet.

### System Limitations

- Detection may be affected or delayed in some environments. If the radar reflective cross section of the target (a bicycle, three-wheelers, carriage, motorized bicycle or motorcycle, for example) is too small, the system may not be able to establish its distance to the target ahead, resulting in either late or no response to those vehicles.
- The system may be affected or give no response in the following cases:
  - On rainy, snowy or foggy days, or exposure to direct sunlight or glaring lights, or significantly varying lighting conditions.
  - Dirty, hazy, damaged or blocked sensor.
  - Malfunction of front mmWave radars due to interference from other front millimeter-wave radar sources such as strong radar reflection in multi-story parking lots.
- In complex traffic, the system may be unable to properly respond to the following circumstances:
  - Pedestrians or vehicles move too quickly into the sensor's detection range.
  - Pedestrians are obscured by other objects.
- Pedestrian outlines are indistinguishable from the surroundings.
- Pedestrians are not detected, due to, for example, coverage by special clothing or other materials.
- The vehicle is on a sharp curve.

### Precautions

- The AEB system cannot ensure zero collision. In complex traffic, the system cannot always clearly identify all the vehicles or pedestrians. It may trigger unnecessary warning or braking action for well covers, iron plates or road signs.
- Make sure to drive safely and observe surrounding traffic conditions. The AEB is not a substitute for normal braking operation.
- Do not overly rely on the AEB system as this may result in accidents. The system is only an auxiliary safety tool. The driver must always keep a safe distance from vehicles ahead, control the speed, be ready to brake or steer away when necessary. The driver must keep control of vehicle at all times and is responsible for the driving safety.
- The AEB system is activated only when it exceeds certain speeds. Careful driving is always required, because the system may not be triggered correctly.
- The AEB system cannot work normally when the ESC function is disabled or the fault light is on.
- If FCW gives an alarm, the driver must brake based on traffic conditions to decrease vehicle speed or steer away from obstacles.
- If the vehicle travels too close to the vehicle ahead for too long, a safety distance warning will be given.

If the vehicle ahead brakes suddenly, collision may be unavoidable.

- The system will not trigger AEB when the driver is aware of an emergency warning but turns the steering wheel, accelerates or brakes.
  - Front mmWave radar sensors may have a transient function failure from limited detection if the vehicle runs under special conditions, such as circular ramps or tunnels, for an extended period. The function can be recovered by restarting the vehicle or driving on normal roads for a while.
  - Sometimes the surfaces of front mmWave radars or the multi-purpose camera are dirty or obscured by foreign objects. Clean them in time to prevent FCW and AEB from malfunctioning.
  - As the pedestrian protection function is limited by certain physical conditions, the driver must take timely and effective control of the vehicle under dangerous conditions.
  - Note that the system cannot completely protect pedestrians or avoid accidents and severe injuries on its own.
  - Under certain complex conditions, such as on winding roads, the pedestrian protection function may trigger unnecessary warning or braking.
  - System failure may trigger wrong warnings or braking. This may be caused, for example, by the misalignment of the front mmWave radar or multi-purpose camera.
  - The brake pedal becomes harder if AEB is triggered. A large amount of hydraulic pressure will be required to push the caliper in a short time and there will be a sizzling noise.
- The AEB system is triggered only with doors closed and seat belts fastened. It fails to work in the following cases:
    - Any door is not closed or it is opened when the vehicle is moving.
    - The seat belt is not fastened or it is unfastened when the vehicle is moving.
    - The driver accelerates or decelerates rapidly or turns the steering wheel quickly.
  - System performance may be reduced in the following cases:
    - Strong front bumper impact from accidents or other causes.
    - Improperly inflated or worn out tires.
    - Unqualified tires installed.
    - Snow chains installed.
    - Use of a small spare tire or tire repair kit.
  - Make sure to go to a BYD authorized dealer or service provider for professional calibration of the front mmWave radar or multi-purpose camera in any of the following situations:
    - The front mmWave radar or multi-purpose camera has been removed.
    - Toe-in or rear camber has been adjusted during wheel alignment.
    - The position of front mmWave radars or multi-purpose camera change after a collision.
  - Do not attempt to test the AEB system on your own using objects such as carton, iron plate, dummy, etc. The system may not work properly and thus result in accidents.



## WARNING



- FCW and AEB serve as driver assistance functions only, so the driver is responsible for driving safety.
- Influence of weather, road conditions, and other factors may cause FCW and AEB to fail.
- Use FCW and AEB based on your needs, traffic, and road conditions.

## Front Cross Traffic Alert (FCTA) and Front Cross Traffic Brake (FCTB)

Front cross traffic alert (FCTA) and front cross traffic braking (FCTB) detects vehicles crossing the driveway at the front through mmWave radars on both sides of the front bumper to alert the driver and engage the brake if necessary. At low vehicle speeds, when the system detects a risk of collision with a vehicle crossing the driveway at the front, it provides the driver with visual and audible alerts; in the event of an impending collision, the vehicle brakes automatically.

### How to Use

- To enable or disable FCTA/FCTB by going to infotainment touchscreen  → ADAS → Safety Assist.
- When FCTA is activated, side mirror warning indicators flash and an audible alarm sounds.
- When FCTB is activated,  is displayed on the instrument cluster and an audible alarm sounds, with AEB automatically braking the vehicle.

- In the event of FCTA/FCTB malfunction,  is displayed on the instrument cluster.
- If you disable FCTA/FCTB manually,  is displayed on the instrument cluster.

### Precautions

- While the system provides assistance in monitoring front left and right sides, it cannot replace the driver's observation and judgment. The driver must keep control of vehicle at all times and drive properly and is responsible for the vehicle.
- When a target vehicle is approaching from the side at a high speed, the FCTA/FCTB system may not be able to provide adequate warning.
- The driver must ensure the normal operation of the system, keeping mmWave radars on both side of the bumper in good condition. For example, dirt, snow, or other obstructions need to be cleared right away.
- In addition, detection may also be affected or delayed by noise or electromagnetic interference.
- Under some circumstances, it is difficult for the system to assist the driver, and detection may be affected or delayed. Possible circumstances include, but are not limited to:
  - The vehicle coming from the side suddenly changes the lane.
  - The target vehicle is obscured.
  - The radar cross section of the target vehicle (for example, a bicycle or electric moped) is too small.
  - Severe weather, such as rain or snow.

- MmWave radar(s) come off, are loosely installed, or are blocked.
- The vehicle encounters complex metal guardrails or similar road conditions.
- The system does not work when:
  - Targets are outside the mmWave radar's detection range.
  - FCTA or FCTB is switched off.
  - The vehicle is not in Drive.
  - Four doors are open.
  - System initialization has not been complete yet.
  - MmWave radar(s) fail.
  - Vehicles coming from the front left or right side are detected too late at sharp turns, slopes, or other settings.
- Influence of vibration or collision on mmWave radar sensor calibration can degrade system performance. If this is detected, contact a BYD authorized dealer or service provider.

### **WARNING**



- FCTA/FCTB serves as driver assistance only, so the driver is responsible for driving safety.
- Influence of weather, road conditions, and other factors may cause FCTA or FCTB to fail or lead to late braking.
- Use FCTA/FCTB based on your needs, traffic, and road conditions.

## Intelligent High Beam Control (IHBC)\*

Intelligent High Beam Control(IHBC) assesses current driving conditions by

using multi-purpose camera sensors and automatically activates or deactivates the high beam accordingly, when vehicle speed exceeds 35 km/h.

### Status Description

- IHBC standby:
  - When the function is enabled but not activated yet,  is displayed on the instrument cluster.
- IHBC activated:
  - With the function enabled, when the light switch is on "Auto", the light meets conditions, and vehicle speed exceeds 35 km/h,  is displayed on the instrument cluster.
- AFL failure:
  - HMA has failed, and  is displayed.

### How to Use

- Enable or disable IHBC in the infotainment touchscreen →  → ADAS → Driving Assist. When the vehicle is started, the system defaults to previous settings.
- With the function enabled, when you set the light switch to the auto lights position, the light meets conditions and vehicle speed exceeds 35 km/h, the system automatically switches between low and high beams based on the current driving environment.

### Precautions

- IHBC is an auxiliary light control function. While it is recommended to use the system at high vehicle speeds, the system cannot completely



replace the driver. The driver must observe road regulations and actively switch between high and low beams according to road condition changes at all times.

- Beam switching is suppressed if the vehicle is in a high dynamic state, for example when ABS or ESC is activated.
- IHBC exits when you turn fog lights or turn signals on, set wipers to high-speed mode, are backing up, or set the light switch to a position other than auto lights, or when the environment has too much lighting.
- Even when IHBC is working, the driver must respond to possible situations where the IHBC is triggered in error or fails to work due to unavoidable environmental factors and conditions. Typical situations are:
  - The driver's stick operation to switch to the high beam is prioritized.
  - The weather, such as fog, rain or snow, is extremely terrible for driving.
  - There are traffic participants with poor lighting (such as pedestrians and bicycles), railways or waterways nearby, or wild animals on the roads.
  - There are strongly reflective objects around, such as traffic signs on highways and water reflection on the road surface.
  - The front windshield is dirty, covered in mist, or blocked by stickers or decorations.
- In case there is a collision or the sensor has been reassembled, it is recommended to go to a BYD authorized dealer or service provider for sensor calibration so as to avoid affecting system performance.

## Lane Departure Assist (LDA)\*

### Lane Departure Warning (LDW)





- The Lane Departure Warning(LDW) system detects the lane lines ahead through a multi-purpose camera. When the vehicle speed is 60 - 150 km/h and the driver unintentionally drifts out of the lane, the LDW system warns the driver by steering wheel vibration, sound alarm and instrument cluster prompt.

### Lane Departure Prevention (LDP)

- The Lane Departure Prevention(LDP) system identifies lane lines ahead through a multi-purpose camera. If the driver unknowingly departs from the lane at a vehicle speed between 60 km/h and 150 km/h such that the vehicle is about to roll over lane lines, the system, when activated, slightly turns the steering wheel by providing reverse torque through the electronic power steering (EPS) system to prevent lane departure.
- If LDP system is activated for over five seconds, it gives visual and audible alarms at the fifth second and continues until this activation ends. If the system is activated twice or more within a continued 180-second cycle, the system alarms immediately. For the third activation (and any further ones), alarms are extended by at least 12 seconds.

### How to Use

- To enable or disable LDW or LDP, go to the infotainment touchscreen →  → **ADAS** → **Safety Assist** → **Lane Departure Assist**.

- There are three LDW modes: audible alarm only, steering wheel vibration only, and combination.
- When LDW or LDP is enabled,  is displayed on the instrument cluster.
- When activated, LDW gives alarms (in the form of audible and visual alarms, and steering wheel vibration). On the instrument cluster, virtual lane lines on the side where the vehicle rolls over lane lines turn red.
- When activated, LDP gives alarms (in the form of audible and visible alarms). On the instrument cluster,  flashes twice, virtual lane lines on the side where the vehicle rolls over lane lines turn blue.
- In the event of malfunction,  is displayed.
- If you disable LDA manually,  is displayed.

### System Limitations

The LDA system may detect incorrect or no lane lines in complex traffic. In the following situations, the system may fail or its performance significantly degrade:

- Poor visibility on snowy, rainy, or foggy days
- Dirty or fogged windshield, or blocked multi-purpose camera.
- Glaring from direct sunlight, reflection in puddles, or oncoming vehicles
- Sudden changes in light, such as when the vehicle is entering or exiting a tunnel.
- Lane lines obscured by tree shadows on roads in direct sunlight on sunny days.

- Unidentifiable road boundary with grass, soil, or curb.

### Precautions

- LDW will be suppressed if a turn signal is used and the vehicle changes lane as indicated by the turn signal.
- LDW may be suppressed if the vehicle travels over lane lines, or lane lines are unclear, too thin, worn, blurred or covered by dirt/snow.
- LDW may be suppressed if the lane is too wide or too narrow, the number of lanes increases or decreases, lane markings change suddenly on ramps or exits, or in situations of complex line arrangements.
- LDW may be suppressed on slopes or winding roads when the vehicle travels too close to the vehicle ahead or when the vehicle ahead obscures lane lines.
- LDW may be suppressed when the vehicle jolts, accelerates or decelerates too quickly, or takes a sharp turn due to road conditions during driving.
- The system operation may be affected if the windshield within the visual field of the multi-purpose camera is cracked, if the front windshield glass is dyed or coated in a manner that is not compliant with standards, if any reflective object is placed on the dashboard, or if any other object interferes with camera sight.
- For safety reasons, do not test LDW function on your own. The function will be interrupted if the multi-purpose camera is blocked by any object or exposed to strong lights. The function will temporarily exit if the view is temporarily covered and disturbed by strong light and will recover once conditions return to normal. If it does not, it is recommended to contact a BYD authorized dealer or service provider.

- Disabling LDW is recommended in the following circumstances:
  - Unbridled driving behaviors: changing lanes quickly without turning on turn signals; rolling over lane lines for overtaking; accelerating or decelerating quickly when rolling over lane lines, etc.
  - Severe weather conditions.
  - On uneven roads
- Situations where lane lines may not be identified include, but are not limited to:
  - Unclear lane lines
  - Incomplete lane lines
- Situations that may cause failure or late function activation of the multi-purpose camera include, but are not limited to:
  - The multi-purpose camera comes off, is loosely installed, or is blocked.
  - The vehicle is running under extreme weather, such as rain, snow, or smog.
  - The multi-purpose camera is partially or completely blocked.

### **WARNING**







- LDW serves as a driver assistance function only, so the driver is responsible for driving safety.
- Weather, road conditions, and other factors may affect normal use of LDW.
- Use LDW based on your needs, traffic, and road conditions.

## Emergency Lane Keeping Assist (ELKA)\*

Emergent Lane Keeping Assist(ELKA) identifies lane lines ahead through a multi-purpose camera and identifies vehicles approaching from behind on the adjacent lanes through rear corner mmWave radars. It comes to work within the 60 km/h-150 km/h vehicle speed range when the vehicle drifts out of solid lane lines, is about to cross a road edge, or has a risk of colliding with oncoming vehicles or vehicles that are passing it on adjust lines. The system activates EPS system to provide reverse torque, keeping the vehicle in the current lane.

### How to Use

You can enable or disable ELKA on the infotainment touchscreen →  → **ADAS** → **Safety Assist**.

- When ELKA is active,   flashes on the instrument cluster.
- In the event of ELKA malfunction,   is displayed on the cluster.
- If you disable ELKA manually by pressing buttons,   is displayed.

### System Limitations

ELKA may detect incorrect or no lane lines in complex traffic. In the following cases, the system may fail to work or its performance degrades significantly.

- Poor visibility on snowy, rainy, or foggy days.
- Dirty or fogged front windshield, or blocked multi-purpose camera
- Glaring from direct sunlight, reflection in puddles, or oncoming vehicles

- Sudden changes in light, such as when the vehicle is entering or exiting a tunnel
- Lane lines obscured by tree shadows on roads in direct sunlight on sunny days
- Unidentifiable road boundary with grass, soil, or curb

### Precautions

- Situations where lane lines may not be identified include, but are not limited to:
  - Pedestrians, animals, and specialty or specially-shaped vehicles
  - Unclear or incomplete lane lines.
- Situations that may result in detection failure of the multi-purpose camera or late alarms include, but are not limited to:
  - The multi-purpose camera comes off, is loosely installed, or is blocked.
  - The vehicle is running under extreme weather, such as rain, snow, or smog.
  - The multi-purpose camera is partially or completely blocked.
- Situations that may result in detection failure of mmWave radars or late alarms include, but are not limited to:
  - MmWave radars came off, are loosely installed, or are blocked.
  - The vehicle is running under extreme weather, such as rain, snow, or smog.
  - The vehicle encounters certain metal guardrails or similar road conditions.

### WARNING

- ELKA serves as driver assistance only, so the driver is responsible for driving safety.

### WARNING

- Weather, road conditions, and other factors may affect the normal operation of ELKA.
- Use ELKA based on your needs, traffic, and road conditions.

## Blind Spot Assist (BSA)\*

- Blind spot assist (BSA) includes blind spot detection (BSD), rear cross traffic alert (RCTA), rear cross traffic braking (RCTB), rear collision warning (RCW), and door open warning (DOW). It detects environment behind the vehicle through radars installed on both sides of the rear bumper so as to remind the driver of safe driving.

### Blind Spot Detection(BSD)

- At vehicle speeds between 15–150 km/h, if rear corner mmWave radars detect a vehicle in blind spots on a vehicle approaching quickly from the adjacent lane, the indicator\* on the corresponding side mirror lights up. If the turn signal for the same side is turned on at this moment, the alarm indicator\* on the side mirror flashes to alert the driver of a risky lane change.



### Rear Collision Traffic Alert(RCTA)

- When the vehicle is reversing at a speed no more than 15 km/h, RCTA detects the vehicles traveling in the

blind spot at the back through rear corner mmWave radars. If the system determines that a vehicle approaching from behind poses a risk of collision, the side mirror warning indicators flash and an audible alarm is given to alert the driver, reducing the possibility of collision.

#### Rear Collision Traffic Alert (RCTA)

- When the vehicle is reversing at a speed no more than 9 km/h, RCTA detects the vehicles traveling in the blind spot at the back through rear corner mmWave radars. If the system determines that a vehicle approaching from behind poses a risk of collision, it performs emergency braking automatically.

#### Rear Collision Warning(RCW)

- At vehicle speeds no higher than 146 km/h, if the rear corner mmWave radar detects a risk of collision with a vehicle approaching quickly from behind on the current lane, the hazard warning light turns on to warn the driver in that vehicle against a possible collision.



#### Door Open Warning(DOW)

- DOW is realized with rear corner mmWave radars installed on both sides of the rear bumper. When the vehicle is stationary with doors unlocked, the system keeps indicators on side mirrors solid on to warn the driver if moving objects, such as bicycles or automobiles, approach from behind on an adjacent lane. If the driver attempts to open the door at this time, indicators\* on side mirrors begin to flash and a chime sounds.

#### Function Button Operation

Enable or disable BSD, RCTA, RCTB, RCW, or DOW in the infotainment touchscreen →  → ADAS → Safety Assist. When the

vehicle is started, the system defaults to previous settings.

- When the blind spot assist system is disabled, no relevant indicators are displayed on the instrument cluster.
- When the blind spot assist system is standing by, if vehicle conditions, such as speed or gear status, do not meet the requirements of any function,  is displayed on the instrument cluster and blind spot assist will not be activated.
- If the blind spot assist system malfunctions,  is displayed on the instrument cluster.
- When the blind spot assist system is active,  is displayed, meaning that the function has been activated and can trigger alarms at any time.

#### Precautions

- While the BSA system provides assistance in monitoring blind spots of rearview mirrors, it cannot replace the driver's observation and judgment. The driver must keep control of vehicle at all times and drive properly and is responsible for the driving safety.
- The BSA system may not give proper warnings on target vehicles approaching from behind at a high speed.
- The driver must ensure the normal operation of the BSA system, keeping BSD rear corner mmWave radars in good condition. For example, dirt, snow, or other obstructions need to be cleared in time.
- If unrelated targets at the rear side or in the rear (such as large roadside barriers used during road repair, large

billboards by the road, reflectors in tunnels, or other objects with a large reflection cross-sectional area) are wrongly selected as target vehicles, the BSA system will give an alert.

### System Limitations

- Under some circumstances, it is difficult for the system to assist the driver, and detection may be affected or delayed. Possible circumstances include, but are not limited to:
  - The vehicle coming from behind changes the lane suddenly.
  - Vehicles coming from behind are detected too late at sharp turns, slopes, or other settings.
  - The target vehicle is obscured.
  - Vehicles come from behind at a relative speed above 80 km/h.
  - The vehicle is on a curve which is too sharp, or is entering or exiting a curve.
  - The vehicle is running under severe weather, such as rain or snow.
  - Rear corner mmWave radar(s) come off, are loosely installed, or are blocked.
  - The vehicle encounters certain metal guardrails or similar road conditions.
  - Targets that may not be responded include, but are not limited to, pedestrians and animals.
  - The environment contains electromagnetic interference or other influences.
- Vibration or collision influence on sensor calibration of BSD's rear corner mmWave radars can degrade system performance. If this is detected, contact a BYD authorized dealer or service provider.

### WARNING

- Blind spot assist serves as a driver assistance function only, so the driver is responsible for driving safety.
- Influence of weather, road conditions, and other factors may cause blind spot assist to fail.
- Use blind spot assist based on your needs, traffic, and road conditions.

## Head-up Display (W-HUD)\*

Head-up Display: The head-up display (HUD) function projects important information on the instrument cluster, including vehicle speed, gear, etc., into the driver's field of view on the front windshield. It improves driving safety by preventing the driver from frequently changing the focus of eyes.

### How to Use

- To enable or disable HUD, go to the infotainment touchscreen →  → **Vehicle**.
- By factory default, HUD is on and the image is displayed. When it is disabled, no HUD image is displayed. The system defaults to the previous settings when the vehicle restarts.

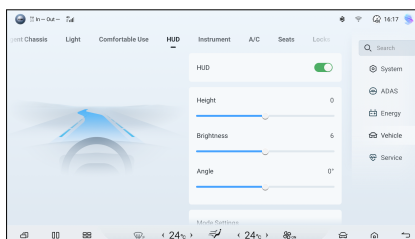

- Height adjusting: adjust the height of HUD virtual image in between -10 and 10. A total of 21 values are available, and the default value is 0.
- Brightness adjusting: adjust the brightness of HUD virtual image in between 1 and 11. A total of 11 values are available, and the default value is 6.
- Whirling adjusting: adjust the angle of HUD virtual image. A total of 11 values are available, and the default value is 0°.
- Mode setting: select Classic (default setting) or Snow mode according to the environment of the vehicle.
- Settings optional for display: Safe driving assistance can be selected and is enabled by default.



#### CAUTION

- Make sure that the head-up display is unobstructed.
- Wipe the dust on the HUD dust-proof board with a soft cotton cloth or paper towel.
- No water or other liquid is allowed to flow into the opening of the head-up display.

## Driver Monitoring Systems (DMS)

Driver monitoring systems (DMS), including fatigue and distraction monitoring, is designed to monitor the driver's driving status with a camera and assess it. Based on the assessment, the system alerts the driver in a timely manner. The monitoring data will not be saved or uploaded to the server but instead will be deleted immediately after the assessment is complete.

### How to Use

- The camera for DMS is mounted on the A-pillar of the driver's side. Make sure the camera is unobstructed before use, or DMS may not function normally.
- To enable or disable driver fatigue or distraction warning (both enabled by factory default), go to infotainment touchscreen →  → **Vehicle** → **Cabin Perception**.

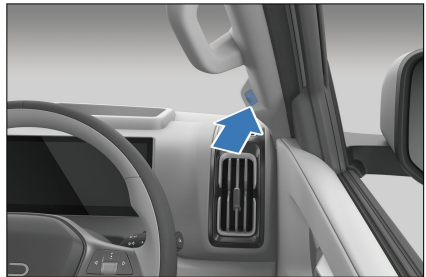

- When the system sounds a fatigue or distraction warning, pressing the scroll button on the steering wheel pauses the warning for 15 minutes during which no warnings will be given.

### Driver fatigue warning

- With the vehicle speed meeting the system activation condition, driver fatigue warning enabled and the camera unobstructed, when the system detects signs of fatigue, such as closing eyes, blinking and yawning, it alerts the driver through a visual warning on the instrument cluster, voice assistant, or an audible alarm.

### Driver distraction warning

- With the vehicle speed meeting the system activation condition, driver distraction warning enabled and the camera unobstructed, when the system detects signs of distraction, such as looking at side mirrors, it alerts the driver promptly through a visual warning on the instrument cluster, or

through intelligent voice or an audible alarm.

### REMINDER

- Clean the DMS camera lens with a clean and soft cloth and exercise caution to prevent any damage to the surface.

### Precautions

- The driver monitoring system is only an auxiliary system and is not capable of effective recognition and alarm-raising in all situations. It cannot completely replace the driver's subjective observation and judgment. The driver must maintain control of the vehicle at all times, complying with all road laws and regulations, and taking full responsibility for the vehicle.
- The proper functioning and accuracy of the driver monitoring assistance can be affected by a number of situations, including but not limited to:
  - Driver monitoring systems are disabled.
  - The camera is directly exposed to strong light.
  - Part of the driver's face is exposed to light or the complete facial features are hard to recognize.
  - The driver wears infrared-blocking glasses or glasses with thick lenses.
  - The driver wears a mask or something that covers the face.
  - The driver is not properly seated or the driver's face is in the blind spot of the camera.

### WARNING

- Pull over as soon as possible when you feel tired.

## Child Presence Detection (CPD)

As an auxiliary reminder function, CPD detects life presence in vehicle when activated. If child presence is detected, an alarm is given in the form of light flashing and honking. The A/C will be switched on when the alarm is escalated. To cancel the alarm, unlock or open any door with mechanical key, smart key, or NFC key.

### Activation Conditions

- CPD is activated when all the following conditions are met:
  - The vehicle is powered off.
  - The driver's door is opened and then closed.
  - All doors are closed.
  - CPD is enabled on the infotainment touchscreen.
  - CPD system has no fault.

### How to Use

- To access the CPD setting interface, go to infotainment touchscreen →  → Vehicle → Cabin Perception. Four options are provided: OFF, ON, Standard, and Delay.
- By default, CPD is enabled with standard alarm mode each time when the vehicle is powered on.
- OFF: CPD function is disabled.
- Delay: the alarm starts in about 5 minutes.



## System Response

### Initial alarm

- When CPD enabled with standard alarm mode, if life presence is detected after the vehicle is powered off and locked, the initial alarm (light flashing and honking) starts within 10 seconds and will last for about 6 seconds.
- When CPD enabled with standard alarm mode, if life presence is detected after the vehicle is powered off but unlocked, the initial alarm (light flashing and honking) starts within 5 minutes and will last for about 6 seconds.
- When CPD enabled with delay alarm mode, if life presence is detected after the vehicle is powered off and the doors are closed, the initial alarm (light flashing and honking) starts within 5 minutes and will last for about 6 seconds.

### Escalated alarm

- If not canceled, the alarm (light flashing and honking) escalates after 80 seconds and will last for about 25 minutes.
- Other system responses: The A/C will be switched on three minutes after alarm escalation, and will keep running for about 30 minutes.

### Alarm canceling

- When alarm is triggered, tap the button on the infotainment touchscreen to cancel the alarm. The setting will remain effective until the vehicle is powered down and on again.
- When alarm is triggered, unlock or open any door to cancel the alarm.

### Message delivery

- The user will receive messages in the BYD app and email of every initial

alarm, escalated alarm and other system responses.

### WARNING

- The system notifies users with light flashing, honking, app message prompts, email message, and A/C operation to reduce the harm to the presence in the vehicle. However, CPD is only an auxiliary system and cannot ensure effective recognition and alarm-raising in all situations. The user must remain alarm at all times and fully responsible for the lives in the vehicle.
- When a reminder is provided, check whether any life presence has been locked inside the vehicle promptly to avoid further safety incident.

### CAUTION

- CPD is only an auxiliary reminder system, and cannot ensure every alarm-raising when life presence is left in the vehicle. The user must remain alarm (especially for child) at all times and fully responsible for the lives in the vehicle.
- The alarm may be given for adults, pets, or other lives detected.
- The alarm may be given for moving objects detected.
- The alarm cannot be canceled by unlocking the vehicle remotely from the app.
- The system may not be able to trigger an escalated alarm or switch on the A/C if the SOC is low. Keeping the vehicle at high SOC is recommended.

## Direct Tire Pressure Monitoring System

- The direct tire pressure monitoring system is an auxiliary system that monitors tire pressure in real time to improve vehicle safety and comfort and reduce tire wear and energy consumption due to insufficient tire pressure.
- You can navigate to the driving information bar by pressing the  button on the steering wheel and to the tire pressure display screen by pressing the button again.

### Tire pressure system alarm

- When the pressure of any tire is lower than 75% of the standard tire pressure and the system is running, the tire pressure fault warning light lights up and the tire pressure value turns yellow. In that case, it is recommended to check for slow air leakage and inflate the tire to the correct pressure value.
- When the temperature of any tire is above 85°C for three consecutive minutes, the tire pressure system gives a high temperature alarm, and the temperature value of the corresponding tire turns yellow. You are then recommended to stop the vehicle and wait for the tire temperature to decrease before further driving.
- When the system is running, if a fault occurs, the tire pressure fault warning light is solid on after flashing, and the message "No Signal" or "Please check TPMS" is displayed on the instrument cluster. In that case, check the tire pressure monitoring module, and check for any surrounding electromagnetic source nearby. If the alarm persists for a long time, please

contact a BYD authorized dealer or service provider.

### WARNING

- The system does not stop vehicle traveling in the event of abnormal tire pressure. Therefore, each time before driving, ensure that the tire pressure conforms to the requirements specified by the manufacturer. If not, do not drive, otherwise vehicle damage or personal injury can occur.
- If pressure is found to be abnormal while driving, check the tire pressure immediately. If the low pressure warning light comes on, avoid sharp turns or emergency braking, and reduce vehicle speed, pull it over to the curb and stop as soon as possible. Driving with low tire pressure can cause permanent damage to tires and increase the likelihood of tire scrapping. Serious tire damage can lead to traffic accidents, resulting in serious injuries or deaths.

### CAUTION

- The running time of the tire pressure monitoring module is related to the daily travel distance and other factors.
- The monitoring module regularly transmits tire pressure and other information to the display. Therefore, if the tire pressure drops suddenly or there is a flat tire, the monitoring module will not transmit data to the display until the next monitoring. In this case, the vehicle may be out of control. If there is a flat tire and monitoring fails to inform,

### CAUTION

or if you feel that there are some tire problems, stop driving immediately instead of waiting for the display to signal an alarm.

- Incorrectly installed monitoring module affects the air tightness of the tire. It is recommended that the installation and replacement of the pressure monitoring module be carried out by professional technicians of a BYD authorized dealer or service provider in accordance with the requirements of the installation manual.
- Since tire pressure varies with regional temperatures, inflate or deflate the tires according to the values displayed on the instrument cluster and the standard tire pressure values.
- The tire pressure monitoring system may be disturbed by non-BYD approved electrical accessories on the vehicle. This is not a tire pressure system failure.
- The tire pressure system needs to be matched again after replacement of wheel rims or spare tire or tire rotations. Please go to a BYD authorized dealer or service provider to re-match the tire pressure.

## Acoustic Vehicle Alert System (AVAS)

### System Function

The Acoustic Vehicle Alert System (AVAS) refers to the broadcast to pedestrians near the vehicle when it is traveling at low speed.

- When driving forward:
  - The broadcast volume increases with the increase of vehicle speed in the range of  $0 \text{ km/h} < V \leq 20 \text{ km/h}$ .
  - The broadcast volume decreases with the increase of vehicle speed in the range of  $20 \text{ km/h} < V \leq 30 \text{ km/h}$ .
  - At speeds above  $30 \text{ km/h}$ , the broadcast sound stops automatically.

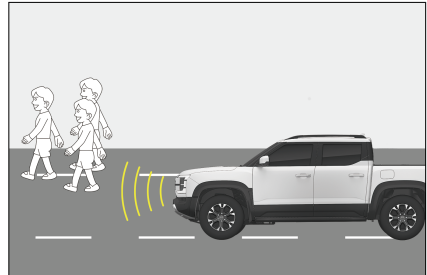

- The vehicle makes a continuous and balanced prompt sound when moving in Reverse.

### Disabling/Enabling the System

- To turn on or off the engine sound simulator, slide down the top status bar on the infotainment touchscreen to display the shortcut screen.
- The system is off by factory default.

### WARNING

- The AVAS pause switch can only be used if there are no other road users within a short distance, and no audio prompt is needed considering the surroundings (for example, in a traffic jam or on the motorway). As long as pedestrians may appear around the vehicle, the AVAS needs to be turned on.
- If the vehicle is running at low speed with AVAS turned off, it is unable to alert pedestrians that

## WARNING

the vehicle is approaching, which may cause car accidents and even casualties in severe cases.

- If the AVAS prompt sound cannot be heard when driving at a low speed, stop the vehicle in a relatively safe and quiet place, open a window, then drive at a constant speed of 20 km/h in "Drive" and check whether an audio prompt can be heard from the front of the vehicle. If it is confirmed that there is no sound, it is recommended to contact a BYD authorized dealer or service provider to deal with it.

## Panoramic View\*







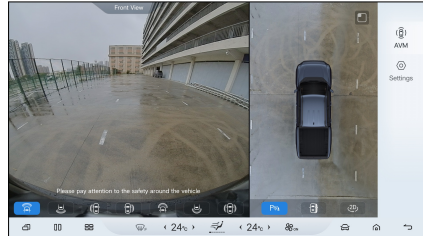







- Panoramic view activation method:
  - To access the panoramic view, press the button on the steering wheel.
  - Alternatively, tap the vehicle view button on the infotainment touchscreen to enter the panoramic view.
  - Shifting to "R" can forcibly start the panoramic view system.
  - Panoramic view system can be activated automatically by settings such as triggering by radars, steering linkage, and triggering in "D".



- Tap the front, rear, right, or left area of the vehicle icon on the right. View of the selected area is displayed in the image section on the left.
- In the single front and rear views, double-tap the image section to switch to a 180° perspective displayed in full screen.



- Tap the radar icon  in the panoramic view to enable the radar display, and tap it again to disable it. When the radar display is enabled, a warning is displayed as the vehicle is approaching an obstacle.
- Transparent panoramic view: Tap the transparent vehicle panoramic view button to switch between transparent and non-transparent vehicle images.
- 2D panoramic view: Tap the 3D panoramic view button (the button turns gray) to access this view.
- 3D panoramic view: Tap the 3D panoramic view button (the button lights up) to access this view.

Panoramic View Icons	Function Instructions
	Panoramic view of non-transparent vehicle
	Panoramic view of transparent vehicle
	3D panoramic view
	2D panoramic view
	Front view
	Rear view
	Left view
	Right view
	2D front view of two directions
	3D front view
	3D rear view
	3D left view
	3D right view
	Radar alarm

- After the vehicle starts, the image before last power-off is displayed on the transparent panoramic view screen. Foreign bodies shown may be inconsistent with the actual ones in the underbody and surrounding blind areas. The underbody image update will begin only after the vehicle has started to run and will be complete when the vehicle has been driven beyond its length.

 **WARNING**

- The panoramic view system provides transparent panoramic view to show the image below the vehicle. This function is only for assisting in the observation of area below the vehicle during parking/driving. Investigation of foreign objects below the vehicle and dangerous situations should be carried out in any other manner to ensure the safety of personnel and the vehicle.

 **WARNING**

- This system uses wide-angle fish-eye cameras, so some displayed objects may be different from the actual ones in shape.
- The panoramic view system is only to be used for parking/driving assistance. It is not safe to rely solely on this system to park or drive the vehicle, because there are some blind spots in front of and behind the vehicle. The surroundings of the car should be observed in other ways during the parking/driving process, so as to avoid accidents.
- When the side mirrors are not extended in place, do not use the panoramic view system; and when the panoramic view system is used for operating the vehicle, ensure that all the car doors are closed.
- The distance to an object displayed on the panoramic view screen may be different from the distance perceived subjectively, especially when the object is closer to the vehicle. Assess the distance in various ways.
- Cameras are installed above the front grille, the lower parts of the side mirrors, and the rear license plate. Make sure the cameras are unobstructed.
- To prevent affecting camera performance, avoid spraying directly on the cameras when washing the vehicle body with high-pressure water jet. Wipe any water or dust off the camera in time.
- Protect the cameras from any impact to prevent damage or malfunction.

 **WARNING**

- After the vehicle is powered on, if you press the panoramic view start button or shift into Reverse while the infotainment system is not fully activated, the output on the panoramic view screen will be delayed or the screen will flash. This is a normal part of the camera power-on process.
- When the vehicle runs at a low speed, the transparent panoramic view function is affected by speed fluctuation or multiple stops, so there will be misalignment between the images below the vehicle and that outside the vehicle.

## Parking Assistance

- During vehicle parking, the parking assist system detects obstacles by sensors, and prompts the driver with the proximity of obstacles by an image on the infotainment touchscreen and a speaker alarm.
- The parking assist system helps with reversing. Pay attention to the environment behind and around the vehicle during reversing.
- When you reverse the vehicle, a reversing image will be displayed on the infotainment touchscreen automatically.
- For your driving safety, when the reversing image is displayed, all buttons will be disabled except some volume and calls-related buttons.
- After reversing ends, the interface will be restored.

### ⚠ CAUTION

- When the vehicle speed is over 10 km/h, the parking assist system will cease to operate.
- Do not place any articles within the sensors' working range.
- To prevent sensor malfunction, do not wash the sensor area with water or steam when washing the vehicle.

### Reversing Radar Power Switch

- Turn the parking sensors on or off with the parking radar switch or on infotainment touchscreen →  → **ADAS** → **Parking Assist**.
- When the ignition is switched on, the parking assist system is enabled automatically.

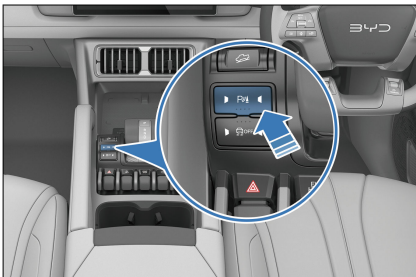

- When the parking assist system is enabled, the vehicle is not in "P", and the EPB and AVH are released, the obstacle detection mode of the parking assist system is enabled. When enabled, the system raises an alarm if obstacles are found surrounding the vehicle; when disabled, it does not.

### Sensor Type

- When the sensor detects an obstacle, an image is displayed on the infotainment touchscreen according to the location of the obstacle and its distance from the vehicle.
- When the driver conducts parallel parking or reverse parking, the sensor measures the distance between the vehicle and the obstacle and communicates this information through the infotainment touchscreen and the speaker. Be aware of the surroundings when using this system.

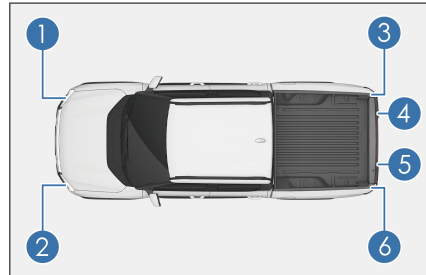

- ① Front right corner sensor
- ② Front left corner sensor
- ③ Rear right corner sensor
- ④⑤ Rear center sensors
- ⑥ Rear left corner sensor





### Distance Display and Speaker

When the sensor detects an obstacle, the location of the obstacle and its approximate distance from the vehicle are displayed on the infotainment touchscreen, and the speaker beeps.

### Working examples of center sensors

Approximate Distance (mm)	Touchscreen Display Example	Alarm Sound
About 700 to 1,200		Slow
About 400 to 700		Fast
About 200 to 400		Continuous

#### Working example of corner sensors

Approximate Distance (mm)	Touchscreen Display Example	Alarm Sound
About 400 to 600		Fast
About 200 to 400		Continuous

#### CAUTION

- 0-200mm is the blind spot range of the system. For the poor detection accuracy and inaccurate alarm information, the alarm prompts in 0-200mm are for reference only.

#### Working Sensors and Detection Range

All sensors are activated upon reversing.

The figure shows the sensors' detection range. Sensors have a range limitation, so the driver must check the surroundings before slowly reversing the vehicle.

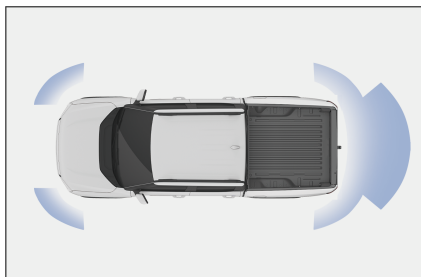

#### REMINDER

- The parking assist system is only used for assistance rather than substitution of your personal judgment. Be sure to operate the vehicle based on your observations.
- Sensors will not work properly if accessories or other objects are placed within their detection range.
- In some cases, the system cannot operate properly and will fail to detect certain objects as the vehicle approaches them. Therefore, be sure to observe the vehicle's surroundings at all times. Do not rely solely upon the system.
- Failure of the parking radar system is indicated by the message "  Parking radar failed, please contact BYD service" on the instrument cluster and





## REMINDER

a beep. In that case, contact a BYD authorized dealer or service provider for inspection as soon as possible.

### Sensor detection information

- Certain vehicle conditions and surroundings may affect the sensors' ability to accurately detect obstacles. Detection accuracy may be affected if:
  - There is dirt, water or fog on the sensor.
  - There is snow or frost on the sensor.
  - The sensor is masked in any way.
  - The vehicle leans significantly to one side or is overloaded.
  - The vehicle is moving on particularly bumpy roads, slopes, gravel or grass.
  - The sensor has been repainted.
  - The vicinity is noisy due to honking of vehicles, motorcycle engines, air brakes of large vehicles, or other noises that produce ultrasonic waves.
  - There's another vehicle with parking assist system nearby.
  - The vehicle is fitted with a tow eye.
  - The bumper or the sensor was hit hard.
  - The vehicle is approaching a high or zigzag curb.
  - The vehicle is driving in the sun or in the cold.
  - The vehicle is fitted with non-original, lower suspension.
- Except as described above, sensors may not be able to correctly determine

the actual distance due to the shape of the object.

- The shape and material of obstacles may prevent sensors from detecting them, especially the following:
  - Electric wires, fences, and ropes
  - Cotton, snow, and other materials that absorb radio waves
  - Any object with sharp edges and corners
  - Low obstacles
  - High obstacles facing outwards towards the vehicle
  - Any object under the bumper
  - Any object close to the vehicle
  - Persons near the vehicle (depending on the type of clothing)
- If an image is displayed on the infotainment touchscreen or there is a beep, it may be that the sensor detects an obstacle or is interfered. If the issue persists, it is recommended to go to a BYD authorized dealer or service provider for a service.



## CAUTION

- To prevent sensor malfunction, do not rinse or apply steam to the sensor area.

## Driving Safety System

For better driving safety, the following driving safety systems works automatically based on driving conditions. However, these systems only provide assistance, and excessive reliance on them is not recommended.

## Intelligent Power Braking System

- The intelligent power braking system is an advanced decoupled electro-hydraulic brake system, incorporating vacuum booster, electronic vacuum pump, Antilock Braking System (ABS), ESC system and other features.
- The system assists vehicle braking according to the driver's demands. It offers advanced control functions such as anti-lock braking system (ABS), electronic brake force distribution (EBD), traction control system (TCS), vehicle dynamic control (VDC), adaptive cruise control (ACC), automatic emergency braking (AEB), comfort stop (CST), cooperative regenerative brake systems (CRBS) to improve vehicle stability and comfort, and the recovery efficiency of brake energy.

### Vehicle Dynamics Control(VDC)

When the vehicle turns suddenly while running, the VDC system determines the driver's intention based on such information as steering wheel's angle and vehicle speed, and continuously compares with the actual condition. If the vehicle swerves from the normal lane, the VDC corrects the situation by engaging brakes to the corresponding wheels to help the driver control skidding and maintain directional stability.

### Traction Control System(TCS)

TCS prevents the drive wheels from skidding during acceleration by reducing the motor power, and, when necessary, applies braking forces to prevent drive wheels from spinning. It makes it easy for the vehicle to start, accelerate, and climb under adverse driving conditions.

## WARNING

- TCS may not work effectively in the following situations:
  - On slippery roads, even if TCS is working properly, it may not be able to control the direction and meet power requirements.
  - Do not drive in conditions where the vehicle may lose its stability and power.

### Hill Hold Control(HHC)

After the brake pedal is released, HHC maintains brake pressure for one second to prevent backward sliding.

### Hydraulic Brake Assist(HBA)



When you press the brake pedal quickly, HBA detects that the vehicle is in emergency condition. It quickly increases the brake pressure to the maximum so that ABS can intervene more quickly and shorten the braking distance effectively.

### Controller Deceleration Parking(CDP)

When "P" button or EPB switch\* is pressed and held, CDP starts to work and the vehicle brakes at a constant deceleration until the vehicle comes to a stop. If the driver releases "P" button or EPB switch\*, CDP stops functioning.

### Hill Descent Control(HDC)

- Working principle: HDC is a value-added function of the ESC system to improve vehicle comfort. You can enable or disable HDC on the infotainment touchscreen →  → **ADAS** → **Safety Assist**. The main function of HDC is to assist in uphill and downhill slow driving through active braking. When HDC is working, ABS is activated when the wheel slip exceeds the ABS triggering threshold, allowing you to safely and smoothly go downhill, or even reverse.

- Activate HDC:
  - When the speed is below 38 km/h, you can also enable HDC by pressing the HDC switch. When the function is enabled, its status indicator on the instrument cluster is steady on.
- HDC speed control:
  - HDC works at speeds between 11 km/h and 38 km/h, within which you can adjust the speed by pressing/releasing the accelerator or brake pedal. The vehicle speed is set when the accelerator or brake pedal is released. The HDC status indicator flashes to indicate that the HDC is working.
- Deactivating HDC:
  - Press the HDC switch again to disable the function, and the indicator turns off.
  - HDC also automatically stops when the speed exceeds about 65 km/h.
- HDC malfunction:
  - In some special cases such as long downhill, the HDC function may be temporarily disabled due to the high temperature of the brake.
  - A "Please check the HDC system" message is displayed for safety. To restore the function, stop the vehicle until the brake temperature cools down.
- You can select **Comfort** or **Sport** brake assist mode on the infotainment touchscreen →  → **Vehicle** → **Intelligent Chassis**.
- Comfort parking
  - Comfort parking function: When the vehicle decelerates to stop in a non-emergency situation, the intelligent power braking system reduces the stop-instant suspension pitch and impact by controlling the brake pressure of the four brakes, providing a smooth stop feeling for the driver.
  - Go to the infotainment touchscreen →  → **Vehicle** → **Intelligent Chassis** to enable or disable comfort parking.
  - After the function is triggered, the braking distance may increase by 2-5 cm. Increase the distance from the vehicle or obstacle ahead accordingly before stopping your vehicle.
- Brake disc wiping
  - Brake disc wiping function: When the wiper switch is on or the rain sensor detects rain, the integrated brake control system applies a small brake pressure to all four brakes so that pads come into contact with discs to remove the water film from the discs. This shortens brake response time and braking distance.
  - As long as the system detects rain or the wiper ON signal, the brake discs are repeatedly wiped at certain intervals to improve safety.

**Intelligent power braking system has the following new functions compared with the original ESC system:**

- Brake assist mode
  - The brake assist mode is used to adjust the brake pedal feel. The relation curve between the brake pedal depth and the vehicle deceleration varies across different modes for the driver to choose their preferred pedal feel.

**ESC operation instructions**

- ESC working
  - If there is a risk of skidding or backsliding when the vehicle starts on a slope, or if either drive wheel is spinning, the ESC indicator flashes to indicate that ESC system is working.

- Disabling ESC
    - If the vehicle gets stuck in snow or mud, ESC may reduce power output from the motor to the wheels. In this case, you may need to turn off the system to get out of the jam.
  - Turning off ESC
    - To turn off ESC, press and release the ESC OFF button. In addition, ESC checks its working status in real time. If ESC OFF switch is pressed while ESC system is working, the system will complete the active intervention control rather than executes the "shutdown" command immediately. ESC is disabled only after the intervention control is complete.
    - Some ESC functions may be re-enabled if you press the ESC OFF switch again or the vehicle speed exceeds the threshold (80 km/h). In order to prevent ESC from being turned off suddenly, ESC can be activated again only when it is not in a vehicle dynamic intervention state.
  - ESC OFF switch mis-operation\*
    - ESC is considered to be mis-operated if the ESC OFF switch\* is pressed and held for more than 10 seconds. In that case, all internal ESC functions continue to work.
  - Restarting ESC system
    - When the ESC system has been turned off, restarting the vehicle will automatically restart ESC system.
  - ESC system start and speed linkage
    - If the ESC system is turned off, when the vehicle becomes extremely unstable as the speed increases and exceeds the threshold (80 km/h), the ESC system starts on its own.
  - When ESC system is activated
    - If the ESC fault indicator  flashes, drive with caution.
  - When ESC system is disabled
    - Be careful when ESC is disabled, and drive at speeds suitable for road conditions. The ESC system ensures vehicle stability and its driving force. Never turn it off unless necessary.
  - Tire replacement
    - Make sure all tires are of the same size, brand, tread pattern, and total load. In addition, be sure to inflate tires to the recommended pressure.
    - Neither ABS nor ESC will work properly if the vehicle is fitted with different tires.
    - For details on tire or wheel replacement, it is recommended to contact a BYD authorized dealer or service provider.
  - Tire and suspension handling
    - The use of any defective tire or modified suspension affects the driving safety system and may cause the system to fail.
- Multi-Collision Brake(MCB)\*
- If an accident requires airbags activation, the vehicle engages automatic braking.
  - Speed reduction, along with intervention by additional driving systems (ESC and ABS), assists the vehicle to maintain stability and lane position.
  - Hazard and brake lights also light up to alert oncoming traffic and prevent further collisions.
  - To support emergency service rescue and vehicle recovery, brakes will release and brake lights will go off after the accident.

- The driver can interrupt the multi-collision braking\* at any time by accelerating or braking.

### Anti-lock Braking System

- The ABS hydraulic system has two separate circuits, each running diagonally through the vehicle (the right front wheel brake connected to the left rear wheel brake). If one circuit fails, two wheels can still be braked.
- ABS helps maintain the steering control by preventing the wheels from locking when brake is engaged suddenly or on slippery roads.

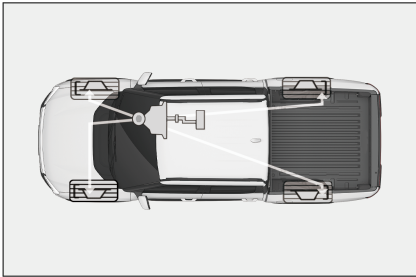

- When the ABS is working, the ESC indicator  will flash and the brake pedal will vibrate, which may produce noise. This is normal because ABS is pulsating the brake quickly. In this situation, you should press and hold the brake pedal instead of pumping the brakes repeatedly. This allows ABS to function as designed. While steering away from danger, a firm and steady pressure should always be maintained on the brake pedal for the ABS to work.

#### WARNING

- ABS cannot work effectively under the following conditions:
  - Tires with inadequate grip are used (for example, excessively

#### WARNING

- worn tires used on snow-covered roads).
- The vehicle skids when driving at a high speed on slippery roads.
- ABS is not designed to reduce the braking distance of the vehicle. Always keep a safe distance from the vehicle ahead when:
  - Driving on slippery, muddy, sandy or snowy roads.
  - Driving on roads with multiple potholes or on uneven roads.
  - Bumpy roads.

#### CAUTION

- If the ABS fault warning light is still on while the braking system warning light is on, immediately park the vehicle in a safe place. It is recommended to contact a BYD authorized dealer or service provider.
- In this case, if brakes are applied, the ABS will not work and the vehicle will become extremely unstable.
- ABS does not reduce the time and distance required to stop the vehicle. This device only helps you control steering when braking. Please always keep a safe distance from other vehicles.
- ABS does not prevent decrease in stability. When applying the brake in an emergency, the steering should be moderate. A large or sharp turn during the driving can cause the vehicle to swerve into



## CAUTION

oncoming traffic or run off the road.

- ABS cannot prevent skidding caused by sudden direction change, such as trying to make a sharp turn or change lanes suddenly. Always drive carefully at a safe speed, regardless of road and weather conditions.
- When driving on wet or soft or uneven roads (such as waterlogged concrete roads, waterlogged epoxy painted roads, sandy roads, snowy roads), vehicles equipped with ABS may require longer braking distances than vehicles without ABS. In such cases, reduce the vehicle speed and keep a greater distance from other vehicles.

# 05

## IN-VEHICLE DEVICES

Infotainment System.....	170
A/C System.....	173
BYD App.....	179
Storage.....	180
Other Devices.....	181

# Infotainment System

## Infotainment Touchscreen

When the ignition is on, the initial screen is displayed for several seconds and the infotainment system starts to work. To better experience infotainment functions, such as apps and Internet calls, the system is recommended to be used after network connection.

① Infotainment touchscreen

② Scroll button

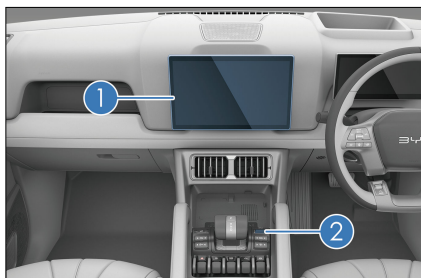

- When the infotainment system is already started, scroll up to turn volume up or down to turn volume down. Volume ranges from 0 to 39. A mute icon is displayed when the volume is 0.
- When an audio is playing, press the scroll button to mute the audio, and press it again to turn off the mute.
- With the infotainment system on, press the scroll button to mute the sound and enter the screen saver interface or turn off the screen (set the screen saver through the infotainment touchscreen →  → **System** → **Display**). Press the scroll button again to turn off the mute and turn on the screen.

- Press and hold the scroll button for three seconds to restart the infotainment system.

### Reset to factory settings

- If you are sure to reset to factory settings, infotainment system will be reset to the factory settings.
  - During the process, do not touch any button on the screen or turn off the power supply, or errors may occur.
  - The process takes two to five minutes, please wait patiently.

### WARNING

- Do not use a high-power inverter in the vehicle, as this may cause infotainment system malfunction.
- Do not format or root the device without authorization, as this may cause infotainment system or vehicle malfunction.
- In driving, please use the infotainment system in landscape mode whenever possible for your safety.

### CAUTION

- To prevent damage to the touchscreen
  - Touch the screen gently. If there is no response, remove fingers from the screen, then touch it again.
  - Clean the screen with a soft cloth. Do not use any cleaning product.
- Using the touchscreen
  - When the screen temperature is low, the image displayed may be







## CAUTION

darker or the system may work slightly slower than normal.

- The screen may be dark or difficult to see when you are wearing sunglasses. In that case, change the viewing angle or take off the sunglasses.
- Touchscreen buttons that are grayed out cannot be operated.
- The touchscreen interface shown here is for reference only, please subject to the actual vehicle.

## Navigation Bar

 : returns to the previous screen or exits the program.

 : returns to the homepage.

 : goes to the setting screen.

 : goes to the app list screen.

 : splits screen if applications support.

 : switches between the landscape and portrait mode of the infotainment touchscreen.

 : goes to the A/C settings screen.



## REMINDER

- The shortcut menu on your vehicle may be different.

## Gestures and Responses

Gestures and associated system responses are:

- Tapping: opens applications, selects functions, clicks icons on the touchscreen, or types characters.
- Dragging: touching and dragging an icon, thumbnail, or preview to the target position to change its location.
- Swiping: operational on homepage and app screens.
- Double-tapping: zooms in an image. Double-tap again to return.
- Spreading/Pinching: zooms in or out an image with two fingers.
- Swiping left/right with three fingers: regulates A/C fan speed.
- Swiping up/down with three fingers: regulates A/C temperature.
- Swiping down from the top of the touchscreen: opens the shortcut menu.
- Swiping up from the bottom of the touchscreen: opens the task management center.
- Sliding from the left/right of the touchscreen: returns to the last screen.

## OTA Upgrade

- The vehicle supports over-the-air (OTA) update. You can update the infotainment system by tapping  → **System** → **Version** → **Vehicle Version** → **Upgrade**.
- When a vehicle software needs to be updated, there will be a prompt message. You can upgrade it immediately, schedule an upgrade, or upgrade it by mobile phone (if supported) according to your use of the vehicle.

## CAUTION

- Do not move the vehicle during the update.
- Before the OTA upgrade, make sure the vehicle is parked in a safe area with the gear in "P", and the mobile communication network connection is normal.
- Make sure your vehicle is fully charged before the upgrade.
- Do not install any third-party devices in the OBD port before or during the update.
- Make sure the vehicle has enough battery power before the update, as it cannot be charged or discharged during the process.
- During the OTA upgrade, all functions are not available except the smart key/microswitch unlocking/locking, interior light switch, hazard warning light, and window switches.
- If the OTA upgrade fails, try it again. If it also fails, contact a BYD authorized dealer or service provider for handling.

## BYD Assistant

BYD Assistant is an intelligent voice assistant that responds to your voice commands, such as requesting navigation, playing music/radio, making a phone call, and controlling in-vehicle devices.

- Waking up BYD Assistant:
  - On the steering wheel, press the  button.

- On the infotainment touchscreen, tap



- Say the wake-up word "Hi, BYD" .
- Your voice commands can be recognized after system wake-up.
- Give any instructions.
  - This may be "Go home" (shortcut locations set), "Play music", "Make a call" (contacts data and Bluetooth connection required), "Set the temperature to 23°C", or "Turn on the seat ventilation for the driver". BYD Assistant then performs the recognized instruction.

## Bluetooth

### Bluetooth connection

1. On Bluetooth Call screen, tap **Please connect Bluetooth** to establish connection.
2. Tap **Available devices** to search.
3. Pair the available device, and make sure the pairing code displayed on your phone is consistent with the code on the touchscreen.
4. Set Bluetooth when connection is complete.

### Bluetooth call

Go to the dialing screen when Bluetooth is connected.

- Tap **Contacts**, **Call log**, and **Missed calls**, or use dial keypad to make a call.
- Slide the call card upwards or tap any empty space to minimize the dialing screen.

## My Car\*

- My car includes vehicle control. Vehicle control consists of shortcut control and 3D vehicle model control.
  - Shortcut control: Shortcut control can be achieved by the left shortcut bar and the shortcut function of the card entrance at the bottom.
  - 3D vehicle model control: Users can click the hot area to operate the vehicle control. The specific vehicle control function is subject to the actual configuration of the vehicle.
  - Body color change: You can switch the body color by tapping the corresponding icon.
  - Vehicle control customization: Users can click more to view all shortcut functions, and long press the shortcut function to drag the position.

### ! REMINDER

- The loaded application is subject to the actual configuration of the vehicle.

## File Management

### New folder

- Go to file management screen to create new folders. You can enter the folder name, and tap OK or Cancel to perform actions.
- Tap the top of the file management screen to change file sources.

### Search

- Tap Search on the upper left corner and enter file names to search for target files.

### Cut/Copy

- Touch and hold any file, select target files and operation (copy, move or delete), and then go to the edit status.

### Rename

- Touch and hold any file, select Rename in dialog displayed, rename the selected file, and then tap **OK**.

### Delete

- Touch and hold any file, select files, and then tap **Delete**.

### Sort

- Files are sorted by name by default. You can also sort them by size, type, or time.

### Attributes

- Touch and hold any file, select a file, and then tap Details to check its attributes.

## A/C System

### A/C Panel

#### Front A/C Panel

- ① A/C ON/OFF
- ② Front windshield defroster

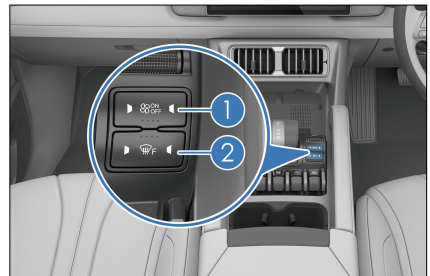

# A/C Operation Interface

## Front A/C Operation Interface



- |   |                            |    |  |
|---|----------------------------|----|--|
| 1 | A/C operation interface    | 9  | Defroster for rear windshield & side mirrors |
| 2 | Ventilation/Heating        | 10 | Circulation mode                             |
| 3 | A/C setting                | 11 | Ventilator                                   |
| 4 | A/C ON/OFF                 | 12 | Front passenger's temperature control        |
| 5 | Auto mode                  | 13 | Air distribution                             |
| 6 | Cooling                    | 14 | Fan speed control                            |
| 7 | Max cooling                | 15 | Driver's temperature control                 |
| 8 | Front windshield defroster |    |  |

## A/C Settings

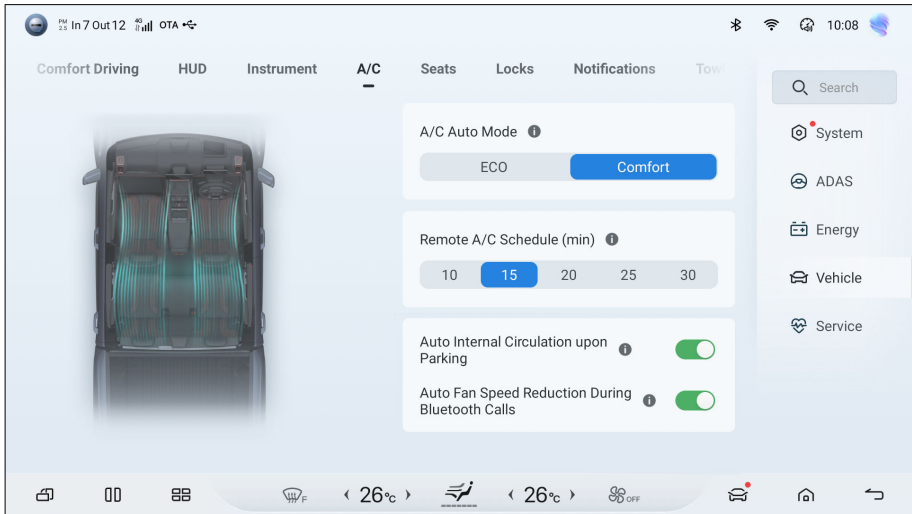

### A/C auto mode

- Two options are available: **Economic** and **Comfort**.

### Remote A/C schedule (minutes)

- Set the time for remote A/C running.

### Internal circulation in parking

- Tap this button to enable this setting.
- Tap this button a second time to disable it.

### Auto fan speed reduction during Bluetooth calls

- Tap this button to enable this setting.
- Tap this button a second time to disable it.

## Function Definition

### A/C ON/OFF

- Tap this button to disable the A/C if it is ON.

- Tap this button to enable the A/C if it is OFF.

### Auto mode

- After tapping this button, its indicator lights up on the front A/C panel, and the compressor status, fan speed and air distribution are adjusted automatically.
- The vehicle exits auto control if fan speed or air distribution is set, and other functions remain in auto mode except for those that have been operated.

### Cooling

- Tap this button for cooling.
- Tap this button a second time to disable it.

### Circulation mode

- Tap this button, and the air inlet mode is recirculation.
- Tap this button for the second time, and the air inlet mode is fresh air mode.

## Ventilator

- Tap this button to activate A/C ventilation control. The outlet air is natural air.
- Tap this button again to exit.

## Front windshield defroster

- Tap this button to enter the front windshield defrost mode which distributes air to the front windshield. The corresponding indicator on the front A/C panel lights up.
- Tap this button again to deactivate and exit the front windshield defrost mode. The corresponding indicator on the front A/C panel turns off.

## Defroster for rear windshield & side mirrors

- Tap this button, and the heating panel in side mirrors will quickly clear the side mirrors. It will be automatically disabled after 15 minutes if there are no other commands.
- Tap this button a second time to disable the function.
- This function is not to be used to dry raindrops or melt snow.

### WARNING

- Do not touch the side mirrors when the rear defroster is activated, because their surfaces will be hot.

### CAUTION

- When cleaning the inside of the rear windshield, take care not to scratch or damage electric heating wires or junctions.

### REMINDER

- Using the side mirror electric heating defrosting function for a long time may cause the mirror to wear out faster. Turn off the defrost button when it is not needed.

## Max cooling

- Tap this button to switch the A/C to the maximum cooling control mode. The temperature is set to "Lo", the fan speed is set to the maximum, the recirculation mode is activated, and air is directed to face level.
- Tap this button again to exit.

## Temperature controls

- Tap the upside arrow or slide it down to increase the temperature. Tap the downside arrow or slide it up to lower the temperature.
- When the temperature is set to the lowest, "Lo" is displayed. When it is set to the highest, "Hi" is displayed.

## Air distribution

- Tap an icon of A/C system on the infotainment touchscreen to select the corresponding air distribution mode.
- You can turn on multiple air distribution modes at a time (up to three).
- Adjustments can be made according to the following air supply illustration.

Face level mode: Air flows to the face level.

Foot level mode: Air flows to the foot level.

Defrosting mode: Air flows to the front windshield and side windows.

## Fan speed control

- Tap the chosen position. The more bars illuminated, the faster the fan speed.

### Independent control

- Tap this button to control the A/C of the driver's seat and the front passenger's seat independently.
- Tap a second time to turn off the independent control.

### Usage Precautions

- To quickly cool down the interior after long exposure to sunlight, drive for a few minutes with the windows open to exhaust hot air and speed up A/C cooling.
- To speed up cooling, adjust the temperature to "Lo" and use the recirculation mode for a few minutes.
- To cool down quickly, activate the maximum cooling control mode to enable the best A/C cooling state. This makes the interior environment comfortable quickly.
- If the A/C effect does not achieve expectations, it is recommended to activate auto mode. In this mode, A/C adjusts to the appropriate ventilation temperature, mode and fan speed for comfort needs of passengers.
- Make sure that the air intake grille in front of the windshield is not blocked (for example, by leaves or snow).
- Avoid blowing cool air onto the windshield in humid weather. The inner and outer temperature difference can cause glass fogging.
- It is recommended to keep the space under the front seats clear to improve air circulation.
- In cold weather, run the fan at high speed for one minute to remove snow

or moisture from the intake passage, which helps reduce fogging.

- Use recirculation mode for a few minutes for cabin quick heating in cold weather, and switch to fresh air mode to prevent fogging after cabin is heated up.
- In dusty or windy conditions, close all windows, switch on the recirculation mode, and turn on the A/C.
- In heating mode, press the compressor control button to light it up (the compressor is turned on), which can reduce airflow moisture.
- In the ventilation mode, the system introduces the natural wind from outside, which is suitable for spring and autumn.

### REMINDER

- A/C odor:
  - It is normal that there may be a damp and moldy smell just after the A/C is turned on. During the operation of the automobile A/C, A/C condensation often remains in the evaporator, and the wet evaporator can easily absorb unfiltered body sweat, smokes, etc., inside the vehicle, resulting in mold on the surface of the wet evaporator surface and odor after long-term fermentation.
- How to prevent and reduce A/C odors:
  - Turn off the A/C and ventilate with natural air before parking to keep the air inside the vehicle relatively dry.
  - Inspect, clean, or replace the filter regularly.

## ! REMINDER

- Try to keep the cabin clean and fresh.
- If the odor does not reduce after the above operations, it is recommended to contact a BYD authorized dealer or service provider.
- In order to reduce odors from the A/C, if the A/C is already turned on, it is normal that the A/C blower may keep running for a while after the vehicle is powered off and locked. No need to worry about it. This is to dry the condensed water on the surface of the evaporator to prevent odor caused by mold fermentation.

## Switching on A/C with Cloud Service App

Tap the A/C card on the BYD app homepage to access the A/C control screen, where you can regulate A/C temperature, set duration, and preset A/C.

- Tap on the plus sign (+) or minus sign (-) to regulate A/C temperature. You can also set rapid heating or rapid cooling.
- Tap **More settings** to set duration and circulation mode.
- Tap **Preset** to set the A/C starting time in the next 24 hours.

## Vents

### Front Center Vent

- Turn the vent stick to adjust airflow or to open/close the vent.

- Use the vent stick to adjust the outlet angle.

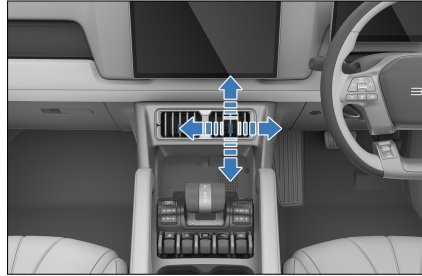

### Front Side Vents

- Turn the vent stick to adjust airflow or to open/close the vent.
- Use the vent stick to adjust the outlet angle.

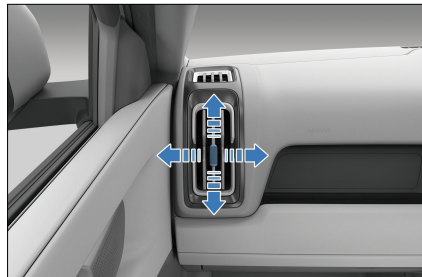

### Rear Center Vent

- Turn the vent stick to adjust airflow or to open/close the vent.
- Use the vent stick to adjust the outlet angle.

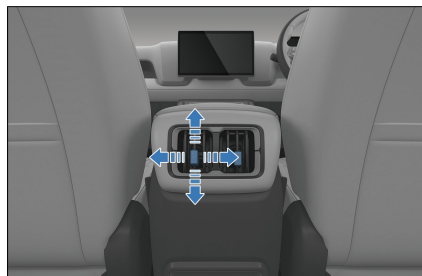



# BYD App

## About BYD App

- BYD app is a mobile application of Internet of Vehicle (IoV) independently developed by BYD. It allows you to control the vehicle remotely and check vehicle conditions, delivering cloud era experience of IoV.
- You can search for "BYD" in application markets such as Google Play and App Store to download and install BYD app.

## Account Registration

App guidance and the following steps give instructions on signing up and logging in after BYD app installation.

1. Open the app, and then tap **Sign up** to go to the registration screen.
2. Enter email address registered in the BYD authorized dealer, tap **Send email** to receive verification code, and then enter the code in the app.
3. Set your password in password setting screen to complete the registration, and then the homepage is displayed.



### CAUTION

- Provide the email address registered at the BYD authorized dealer, or registration will fail.
- In the app, select a country or region on upper right corner of the screen. The default setting depends on your phone setting. If it is not where you make the purchase, change it to the right



### CAUTION

one, otherwise your data will not be accessible.

## Vehicle Condition and Control

The BYD app homepage provides information and control items of the vehicle.

1. The homepage shows remaining driving range, SOC, vehicle error information, and status of vehicle driving, charging, A/C system, door and window states, seat heater, seat ventilator, and tire pressure.
2. Tap lock, unlock, light flashing & honking, or light flashing button to activate the corresponding function.
3. Turn on or off A/C on the app homepage, or tap the A/C card to access other settings in the A/C control screen, such as temperature regulation.
4. At the bottom of the homepage, tap the icon of seats, doors and windows, or tires to go to the associated screens and check their status.
5. If you have multiple vehicles on an account, tap the vehicle name in the upper left corner of the screen to switch between vehicles.



### CAUTION

- The control function of the app is mainly for remote use. To use this function, ensure your phone and vehicle are connected to the Internet.

## Individual Center and Vehicle Management

In BYD App screen, tap My Account to go to the individual center.

- Tap the icon on the top right corner of the vehicle card to edit the vehicle name and license plate number.
- Account and Security: recovers or changes your password.
- Settings: sets message reception, automatic login, and other items.
- About Us: includes privacy policy and information to contact us and give feedback.

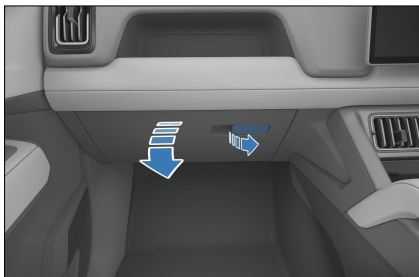

### ! REMINDER

- To reduce risk of injury in the event of an accident or emergency braking, keep the glove box closed while driving.

## Storage

### Door Bins

- There is a door bin on each door for storage of beverage bottles or small items.



### Glove Box

- Pull the handle to open the glove box.
- Push the lid up to close it.

### Center Console Cubby

- Located between the front seats, open the cover to use.



### Seatback Pockets

- There are seatback pockets at the back of the front seats for magazines and newspapers. (The seatback pockets on your actual vehicle may differ.)



## Glasses Case

- Press the lid of the case to open it.

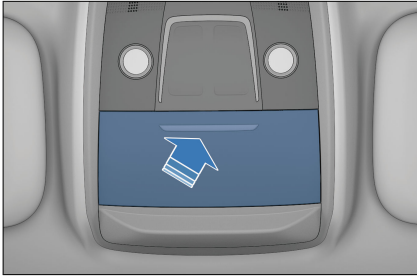

## Cup Holder

### Front Seat Cup Holder

- The front seat cup holder is located in front of the center console cubby.

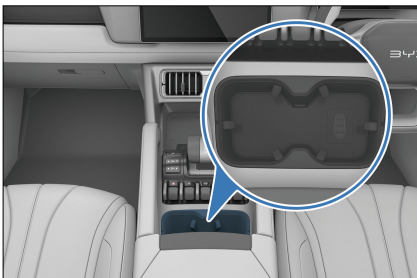

### Rear Seat Cup Holder

- Flip the rear seat armrest, the cup holder can be seen.



## CAUTION

- When using the cup holder, do not start or brake the vehicle suddenly to prevent liquid spillage and burn you or other passengers.
- Do not place an open cup or untightened beverage bottle in the cup holder, so as to avoid liquid spillage when you are opening and closing the doors and driving.
- To ensure safe driving, the driver is strictly prohibited from taking the cup out or placing it in the cup holder while driving.

## Other Devices

### Sun Visor

#### ① Sun visor

- To block sunlight from the front, pull the sun visor down.
- To block sunlight from a side, remove the swivel sleeve from the fixed support and turn the visor towards the side window.

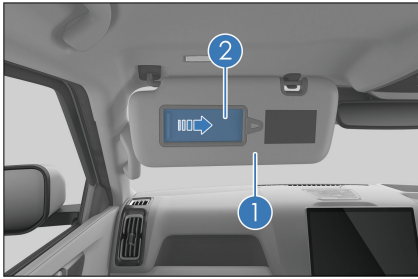

## ② Vanity mirror

- Flip down the sun visor and slide the mirror cover for use.

### ! REMINDER

- Correct use of the sun visor improves driving safety and comfort.

## Grab Handles

Pull the safety handle down for use. Simply let go and allow it to return to its default position.

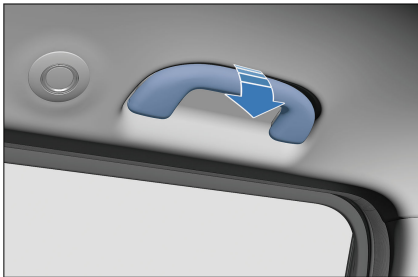

## USB Ports

### Front-Row USB Ports

- The front USB ports are located in the center console cubby.
  - ① Type-A data transmission/charge port

- ② Type-A data transmission/charge port

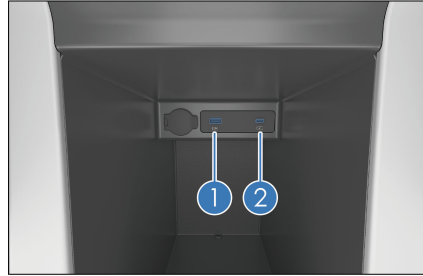

- The ports can be used only when the ignition is on.
- The infotainment system is compatible with USB storage devices up to 128GB. It is not compatible with some USB devices on the market.

### ! CAUTION

- It is recommended to use a USB storage device up to 128GB with a partition format of FAT32.
- Do not use substandard or special USB storage devices to avoid damaging the infotainment system or data in the USB device.

### Rear-Row USB Ports

- The rear USB ports are located behind the center console cubby.
  - ① Type-A charge port
  - ② Type-C fast charge port

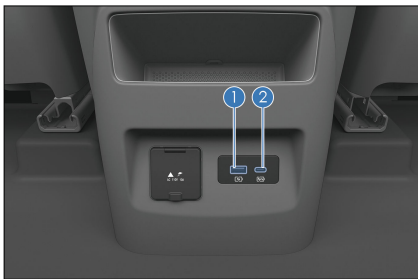

- The power outlet can be used only when the ignition is on.

## On-Board Power Supply

- The standby power supply can be used for accessories with a working current of less than 10 A and electrical power of less than 120 W.
- The 12V auxiliary power supplies power to vehicle accessories.
- The 12V auxiliary power is available only when the ignition is on. Lift the cover to use it.

### Front 12V Power Outlet

- It is located in the center console cubby.



### CAUTION

- To prevent fuses from blowing, the power consumption must not

### CAUTION

- exceed 12V/120W of total vehicle load.
- To prevent draining the low-voltage battery, do not use the 12V auxiliary power supply for a long time when the engine is not running.
- When the 12V auxiliary power is not in use, close its cover. Do not insert any object other than a suitable plug into the 12V auxiliary power socket or let any liquid ingress the socket, as electrical failure may occur.

## Wireless Phone Charger

- The wireless phone charging area is located at the front of the center console cubby. To activate/deactivate wireless charging, tap the wireless charging icon  on the shortcut page after sliding down the top status bar on the infotainment touchscreen.
- After starting the vehicle, put the phone on the non-slip rubber pad in the wireless charging area with the phone screen facing up. The phone automatically begins wireless charging, and a charging icon is displayed on the infotainment touchscreen.

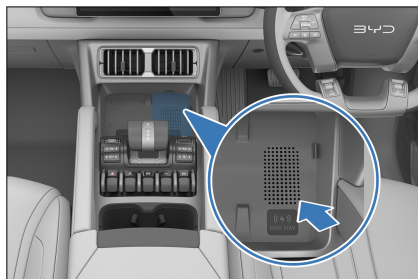

- Wireless phone charging uses a coil to transmit electrical energy to a phone battery through electromagnetic wave induction so that the phone can be charged without a cable connection.

 **CAUTION**

- Ensure your smart key is more than 25 cm away from the wireless charging area when the wireless charging system is working.
- To avoid wireless charging dysfunction or even accidents, do not place coins, metal keys, metal rings, or other articles containing metal on the wireless charging area together with the phone.
- To avoid damage to the charging area, do not place heavy objects on it.
- If the smartphone wireless charging system is faulty and does not work properly, it is recommended to contact a BYD authorized dealer or service provider.
- BYD will not assume any responsibility for any problems caused by improper use. If the product is disassembled or modified, the free warranty will be terminated.
- For safety reasons, do not leave an unattended phone being charged in the vehicle.
- For safety reasons, refrain from checking phone charging status for a long time while driving.
- If a metal item is found between the device and the charging rubber pad during charging, do not remove the metal item

 **CAUTION**

with bare hands immediately to prevent burning.

- For better charging, the center of the phone coil must be aligned with the center of wireless charger (indicated with text in the charging area), or charging may fail.
- Prevent any fluid from coming into contact with the charging area. The wireless charger will malfunction if water enters the wireless charger via the gap around the rubber pad.
- Charging may stop at high temperatures, and will resume once the temperature drops.
- BYD makes no commitments for problems caused by external wireless charging coils. Please use with caution.
- The wireless phone charging system can charge Qi-certified phones, and non-Qi-certified phones are not guaranteed for normal charging.
- To avoid burning cards with chips, such as bank cards, do not place them between the phone case and the phone during charging.

 **REMINDER**

- Only one phone can be charged at a time.
- A phone case that is too thick may prevent charging.
- On bumpy roads, the wireless phone charging may intermittently stop and then resume.



## REMINDER

- Try to ensure that the surface on which a mobile phone is placed is parallel to the charging module. If the phone moves from the wireless charging area and stops charging, move it back.
- If the phone cannot be charged properly, ensure that there are no foreign objects in the wireless charging area, or wait for the wireless charging area to cool down before trying again. If it is still impossible to charge the phone, contact a BYD authorized dealer or service provider.
- After power-off, if the phone is still charging and the driver's door is opened, the instrument cluster sounds an alarm and the message "Please take your cell phone with you" is displayed for five seconds.
- The setting icon for wireless phone charging can be added or removed on the shortcut page of the infotainment touchscreen.
- The wireless charging only works with Qi-certified phones.
- For the purpose of compatibility, the in-vehicle wireless fast charging module may charge slower than the original charger provided by your phone's manufacturer.
- The wireless fast charging power of your phone depends on that supported by the phone, while the in-vehicle fast charging only supports up to 50 W.
- Certain phones may carry outdated charging programs that are not capable of fast charging.





# 06

## MAINTENANCE

Maintenance Precautions.....	188
Regular Maintenance.....	194
Self-Maintenance.....	199

# Maintenance Precautions

## Maintenance Cycle and Items

### Maintenance Plan

- The maintenance plan is designed to ensure stable driving, failure reduction, safe and economical driving.
- The maintenance schedule lists all the maintenance items that are necessary to keep the vehicle in optimum condition at all times.
- The items in the maintenance schedule are important and need to be maintained according to the time interval.
- Hoses with any degradation or damage should be replaced immediately. Rubber hoses (for systems such as A/C, heating, and braking systems) must be checked by professional technicians according to the maintenance schedule.

### Maintenance Schedule Requirements

The vehicle must be maintained according to the regular maintenance schedule.

If the vehicle is operated primarily under one or more of the following special conditions, certain maintenance items may need to be performed more frequently.

- Road conditions
  - Muddy, sandy, or snowy roads.
  - Dusty roads
- Driving conditions
  - Use of towed trailer, camping trailer, or roof rack
  - Repeated short distances are driven within 8 km, and the outside temperature is below zero.
  - Long idling and/or long distance driving at low speed, for example, using the vehicle as a police car, taxis or using it for transporting goods.

### Maintenance Schedule

- **First maintenance:**
  - The vehicle must be maintained at six months or 3,500 km (HEV mileage), whichever comes first.
  - First maintenance items include vehicle basic maintenance, replacement of engine oil and oil filter, and check of engine idle speed and crankcase ventilation system.
- **Routine maintenance:**
  - Routine maintenance include vehicle basic maintenance, maintenance of other items, and engine maintenance.

Vehicle basic maintenance:

After the first maintenance, carry out the basic maintenance according to the following maintenance interval and mileage (total mileage), whichever comes first.

Item	Time and mileage interval for maintenance
Cooling pipe damage and tightly locked connecting parts	Check every 12 months or 20,000 km after the first maintenance

<b>Item</b>	<b>Time and mileage interval for maintenance</b>
Brake friction block and brake discs	Check every 12 months or 20,000 km after the first maintenance
Chassis screws	Check every 12 months or 20,000 km after the first maintenance
Brake pedal and EPB switch	Check every 12 months or 20,000 km after the first maintenance
Brake piping and hoses	Check every 12 months or 20,000 km after the first maintenance
Steering wheel and tie rod	Check every 12 months or 20,000 km after the first maintenance
Drive shaft boot	Check every 12 months or 20,000 km after the first maintenance
Ball pin and boot	Check every 12 months or 20,000 km after the first maintenance
Front and rear suspensions	Check every 12 months or 20,000 km after the first maintenance
Front and rear wheel alignment	Check every 12 months or 20,000 km after the first maintenance
Check tire wear	Check during maintenance and rotate when necessary; Under severe working conditions, check more frequently and rotate when necessary
Wheel bearing clearance	Check every 12 months or 20,000 km after the first maintenance
Spare tire looseness	Check every 12 months or 20,000 km after the first maintenance
Foreign materials on or ablation of the EPS GND point	Check every 12 months or 20,000 km after the first maintenance
EPS connector looseness and connector pin ablation	Check every 12 months or 20,000 km after the first maintenance
EPS ECU corrosion	Check every 12 months or 20,000 km after the first maintenance
Check the door brakes. Remove the dust from the lever with a damp soft cloth,	Check every 12 months or 20,000 km after the first maintenance

Item	Time and mileage interval for maintenance
and apply 0.3–0.8 g of grease to the lever, riveting joint, and rotating shaft.	
Hood lock and fasteners	Check every 12 months or 20,000 km after the first maintenance
Coolant level in expansion tank	Check every 12 months or 20,000 km after the first maintenance
Brake fluid	Check every 12 months or 20,000 km after the first maintenance
Vehicle module DTCs (to be cleared after recording)	Check every 12 months or 20,000 km after the first maintenance
High-voltage battery tray, crash bar, shield, crash valve*, thermal insulation cotton*, and mounting torque	Check every 12 months or 20,000 km after the first maintenance
Powertrain leaks or bumps	Check every 12 months or 20,000 km after the first maintenance
Fasteners such as high-voltage distribution box and DC charging distribution box	Check every 12 months or 20,000 km after the first maintenance, and increase the inspection frequency under special working conditions or severe working condition.
Loose high-voltage wiring harnesses or connectors and pin ablation	Check every 12 months or 20,000 km after the first maintenance, and increase the inspection frequency under special working conditions or severe working condition.
Deformation of or oil stains on the high-voltage module	Check every 12 months or 20,000 km after the first maintenance, and increase the inspection frequency under special working conditions or severe working condition.
Foreign materials on or ablation of charging connector interface	Check every 12 months or 20,000 km after the first maintenance, and increase the inspection frequency under special working conditions or severe working condition.
Wading marks on high-voltage parts	Check every 12 months or 20,000 km after the first maintenance, and increase the inspection frequency under special working conditions or severe working condition.
Vehicle module software update (update if any)	Check every 12 months or 20,000 km after the first maintenance

<b>Item</b>	<b>Time and mileage interval for maintenance</b>
Lamp and LED lighting	Check every 12 months or 20,000 km after the first maintenance
Headlight dimming	Check every 12 months or 20,000 km after the first maintenance
Initial down tilt of low beam	Check every 12 months or 20,000 km after the first maintenance
HEPA filter*	Check every 12 months or 20,000 km after the first maintenance. In case of harsh environment or reduced air outlet, it is recommended to check and replace the A/C filter in time.
Lock nut torque of wiper arm	Check every 12 months or 20,000 km after the first maintenance
Vehicle glass glue	Check every 12 months or 20,000 km after the first maintenance
The fastening of door locks and lock bolts	Check every 12 months or 20,000 km after the first maintenance
Electric fan*	Check every 12 months or 20,000 km after the first maintenance
Loose cooling fan grounding and connectors	Check every 12 months or 20,000 km after the first maintenance
Fuse box and domain controller power terminal connection looseness	Check every 12 months or 20,000 km after the first maintenance
Damage of connectors inside and outside the hood	Check every 12 months or 20,000 km after the first maintenance
Steering shaft lock*	Check every 24 months or 40,000 km after the first maintenance
Electric horn	Check every 24 months or 40,000 km after the first maintenance
Air leakage of exhaust pipe joint	Check every 24 months or 40,000 km after the first maintenance
Appearance bumps of the three-way catalytic converter	Check every 24 months or 40,000 km after the first maintenance
Fuel tank cap, fuel lines and connections	Check every 24 months or 40,000 km after the first maintenance

<b>Item</b>	<b>Time and mileage interval for maintenance</b>
Charcoal canister	Check every 24 months or 40,000 km after the first maintenance

Maintenance of other items: Comply with the following maintenance interval and mileage (total mileage), whichever comes first.

<b>Item</b>	<b>Time and mileage interval for maintenance</b>
High-voltage battery pack sealing	Test every two years or 40,000 km and replace the breather valve if necessary
Engine coolant and drive motor coolant	Replace the long-acting organic acid coolant every four years or 100,000 km
Brake fluid	Check during maintenance and replace every two years or 40,000 km
Front and rear drive gear oil	Check and replace the oil every four years or 60,000 km, whichever comes first.
Check and replace front drive differential gear oil	Replace at 18 months or 23,500 km for the first time; check and replace with the maintenance time of front and rear drive gear oil afterwards
Transmission filter element	Replace the filter (press filter) element every four years or 60,000 km
Spare tire lifter	Retorque every two years or 40,000 km during routine maintenance
Engine maintenance mileage:	mileage (HEV mileage), whichever comes first.
Engine maintenance should comply with the following maintenance interval and	

<b>Maintenance item</b>	<b>Time and mileage interval for maintenance</b>
Engine oil and oil filter	Replace every 12 months or 10,000 km after the first maintenance
Crankcase ventilation system (PCV valve and ventilation hose)	Replace every 12 months or 10,000 km after the first maintenance
Engine idle speed	Check every 12 months or 10,000 km after the first maintenance

Maintenance item	Time and mileage interval for maintenance
Spark plug	Replace at 42 months or 33,500 km for the first time, and every 48 months or 40,000 km afterwards
Fuel filter (non-integrated)	Check and replace at 18 months or 13,500 km for the first time, and replace every 24 months or 20,000 km afterwards
Air filter element	Replace at 18 months or 13,500 km for the first time, and every 24 months or 20,000 km afterwards; Check under severe conditions of use and replace in advance if necessary
Charcoal canister dust filter	Replace every two years or 30,000 km, or upon frequent fuel gun auto shut-off during refueling

### REMINDER

- To keep the high-voltage battery in optimal condition, please fully charge and discharge the vehicle regularly (at least every six months or 72,000 km) for battery self-calibration. You can also contact a BYD authorized dealer or service provider for capacity testing and calibration.
- In following bad working conditions, it is recommended to shorten the recommended routine maintenance intervals according to the actual situation to protect the vehicle.
  - Drive the vehicle in low-temperature environment (ambient temperature <math><5^{\circ}\text{C}</math>) for a long time, and the continuous driving time in HEV mode is short (<math><15\text{min}</math>) every time, or it is frequently driven in a slow crawling condition (vehicle speed <math><10\text{ km/h}</math>) for a long time.

### Note:

- The maintenance period in the table is calculated from the purchase date.
- To keep the vehicle in the optimum state, please operate the vehicle correctly according to the following instructions.
  - Before the first maintenance, the use ratio of HEV mode should not be less than 50% when running in ECO mode.
  - After the first maintenance, the use ratio of HEV mode should not be less than 10%.
- The replacement time of the oil filter can be shortened according to the degree of fouling of the gasoline engine.
- Severe driving conditions refer to:
  - Frequent driving in dusty areas or frequent exposure to salt-laden air.
  - Frequent driving on bumpy, puddled, or mountain roads.
  - Driving in cold weather.

- Frequent and sudden braking.
- Frequent use of a towed trailer.
- Use as a taxi.
- Driving in congested urban areas at temperatures above 32°C for more than 50% of total travel time.
- Driving at speeds over 120 km/h at temperatures above 30°C for more than 50% of total travel time.
- Frequent overloading.

## Regular Maintenance

### Regular Maintenance

- Be sure to maintain the vehicle as per the maintenance schedule to allow it serve in the best working efficiency and reduce fault occurrence.
- Drivers can refer to the maintenance plan for scheduled maintenance intervals, depending on the odometer reading or time interval, whichever comes first.
- For overdue maintenance items, the same time interval should be used for maintenance.
- It is recommended that the maintenance be performed in accordance with the standards and specifications by a local BYD authorized dealer or service provider.
- The maintenance schedule lists the maintenance items and travel time or distance based on the assumption that the vehicle is used as a normal means of transportation to carry passengers and goods that do not exceed the vehicle load limit.



### CAUTION

- Please maintain the vehicle regularly according to the requirements in the Warranty and Maintenance Service Manual of BYD.

### Vehicle Servicing

- Pay attention to vehicle performance, sound changes, and visual evidence that indicates service is required. Under any of the following circumstances, it is recommended to send the vehicle to a BYD authorized dealer or service provider for inspection or repair as soon as possible:
  - Motor start produces unusual noises.
  - Coolant remains overheated, is stagnated or leaks.
  - Motor jams and produces unexpected noise.
  - The motor runs with excessive vibration.
  - The motor fails to get started.
  - Electric assembly leaks oil.
  - Electric assembly emits odors.
  - Power declines significantly.
  - Water leaks from under the vehicle (A/C condensate is normal).
  - Tire deflates; tires make excessive noises at turns; tire wear is uneven.
  - Vehicle leads to one side when driving straight on a flat surface.
  - Suspension unit movement leads to unusual noises.
  - Loss of braking effect; sponge feeling on the brake pedal or clutch pedal; pedal almost contacts the floor;



vehicle leads to one side when braking.

- Motor coolant temperature remains high.
- Battery capacity decreases significantly.
- High battery temperature or overheat protection persists, or there is no power output.
- "Please check the engine system" is displayed on the instrument cluster.
- There is obvious abnormal vibration or noise in the engine compartment.
- The engine leaks oil or water.
- The vehicle exhausts blue smoke or thick black smoke.
- A/C system fails to blow cold or hot air during refrigeration or heating.



#### **WARNING**

- Do not continue driving a vehicle that has not been inspected, as this may result in serious vehicle damage and personal injury.

## Vehicle Corrosion Prevention

**The most common causes of vehicle corrosion are:**

- The underbody of the vehicle is covered in salt, dust, or moisture.
- The vehicle or some of its parts are exposed to high humidity and high temperature for a long time.
- The paint layer or underlayer is scratched by minor collision or by stones and gravel.

**The following rules should be observed to prevent vehicle corrosion:**

- Wash the vehicle frequently.
  - If driving on saline roads in winter or living in coastal areas, wash the landing area of the vehicle at least once a month, and clean the chassis and hubcap with a high-pressure water jet or steam to reduce corrosion. Wash the chassis thoroughly after winter.
  - Wash the vehicle with clean water and neutral detergent.
- Check vehicle paint and trims.
  - Any chip or crack found on the paint must be repaired immediately to prevent corrosion. If fragments or cracks peel off from the metal surface, it is recommended to go to a BYD authorized dealer or service provider for repair.
- Check cabin interior.
  - Moisture and dust buildup under the carpet can cause corrosion. Check the undersides of carpets frequently to make sure these areas are dry.
  - Special care should be taken when the vehicle is transporting chemicals, detergents, fertilizers, salt, and other substances. Such substances should be kept in appropriate containers for transportation. If spillage or leakage is found, clean the vehicle immediately and keep it dry.
- Use fenders.
  - Fenders protect vehicles in saline areas or on gravel roads. The bigger and closer to the ground the fender, the better.
- Park in a well-ventilated and dry area.
- Keep the drain hole of the door unblocked to avoid water accumulation.

## Paint Maintenance Tips

- Clean the vehicle in time.
- Do not perform secondary painting if there is no obvious scratches on the finish, so as to prevent mismatch or color incompatibility.
- When the vehicle is not used for a long period, it should be parked in a garage or a well-ventilated place, and special body cover should be used in winter. Choose a cool place for temporary parking.
- Prevent strong impacts, bumps, or scratches on the paint film of vehicle body. If the paint is scratched, dented or if it peels, it should be repaired in time, preferably by a professional auto beauty provider.
- Do not touch the paint with a greasy hand or cloth. Do not place greasy tools or rub with organic solvents on the vehicle body so as to avoid chemical reactions.
- Paint maintenance must be carried out once a month, or whenever water resistance performance of the vehicle degrades, it should be waxed and be taken to an auto beauty provider for maintenance once every three months to restore the luster of the vehicle paint in time.
- High quality polish and wax must be used. If body finish is severely weathered, use a car cleaning polish in addition to the wax. Carefully follow the manufacturer's instructions and precautions. Chrome finish should be polished and waxed as painted finish.



### CAUTION

- When the vehicle is repainted and placed in a high-temperature paint waxing workshop, the vehicle's plastic bumper must be



### CAUTION

removed to avoid damage caused by high temperatures.

## Exterior Cleaning

- The vehicle must be cleaned in time under the following circumstances, which can cause peeling of paint layer or corrosion of the vehicle body and parts:
  - Driving along the coast.
  - Driving on roads with anti-freeze.
  - Driving on roads covered with coal tar.
  - Resin, bird droppings, or insect carcasses are stuck on the vehicle.
  - Driving in areas with a large amount of smoke, soot, dust, iron filings, or chemicals.
  - The vehicle is visibly soiled by dust or mud.
  - After raining.

## Manual Vehicle Washing

Before washing the vehicle, park it in the shade, and wait for the vehicle to cool down sufficiently.

- Hose off loose dirt, including all mud or road salts at the bottom of the vehicle and on wheel pits.
- Wash the vehicle with neutral agents, the mixing of which should be carried out according to the manufacturer's instructions. Soak a soft cloth with cleaning solution and gently wipe it down along the direction of the water flow. Do not wipe in a circular motion or horizontally.

- Rinse well—Dried washing agent forms markings. After washing the vehicle in hot weather, rinse all parts properly.
- Dry the vehicle with a clean soft towel to prevent stay water marks. In order to prevent scratching, do not rub or apply excessive force on the paint.

### CAUTION

- Do not use any alkaline washing powder, soapy water, detergents, de-waxing detergents or volatile substance (gasoline, kerosene, or solvent).
- When cleaning the combination lights, do not wipe their surface with chemical solvents such as gasoline, alcohol, lacquer thinner, thinner, and carbon tetrachloride. Doing so can cause the combination light casings to crack.
- It is recommended that vehicles traveling in coastal or heavily polluted areas be washed once a day.
- Do not use blades or gasoline to remove hard dirt from the vehicle body. The plastic wheel trim is easily damaged by organic matter. If any organic matter splashes on the vehicle trim, remove it with water and check whether the trim is damaged. Please replace any seriously damaged plastic wheel trim in a timely manner. Otherwise, the trim may fall from the wheel during vehicle movement and cause an accident.
- Do not use abrasive cleaning agents to scrub the bumper.
- Clean polished metal parts with carbon cleaner and wax them regularly for protection.

### CAUTION

- Be careful when cleaning the chassis to avoid cutting hands.

## Automatic Vehicle Washing

When choosing an automated car wash service, be aware of certain types of brushes, unfiltered rinsing water, or machine-specific rinsing procedures that may scratch the paint and affect its gloss and durability, especially for dark-colored vehicles. Before washing the vehicle, it is best to consult the service provider to understand which washing procedures are the safest for the paint finish.

## Interior Cleaning

### REMINDER

- Prevent direct water splash onto the dashboard and floor, or into nearby electrical components when washing the vehicle, as these may cause malfunctions.
- Do not wash the vehicle's floor in case it causes corrosion.

## Carpet

- Clean carpets with a good foam detergent.
- Firstly, use a vacuum cleaner to remove as much dust as possible. Several types of foam detergents can be used. Some are in spray cans, and the others are powders or liquids, which produce foam when mixed with water. Clean the carpets with foam soaked sponge or a brush, scrubbing in a circular motion.
- Do not use plain water, and keep the carpets as dry as possible.

## Seat Belt Maintenance

- The seat belts can be cleaned with neutral soapy water or lukewarm water.
- Scrub the seat belts with a sponge or soft cloth. Check the seat belts for excessive wear, tear, or cut marks.

### WARNING

- Do not clean the seat belt with colorant or bleach. These substances may decrease the seat belt's strength.
- Do not use any seat belt that is not dry.

## Doors and Windows

- Doors and windows can be cleaned with any ordinary detergent.
- Check the door brakes regularly. If a door brake lever is found with visible dust, wipe it with a wet soft cloth. Then apply 0.3 - 0.8 g of lubricant between the bracket and the pull rod riveting shaft, and between the pull rod and the sliding block.

### CAUTION

- When cleaning the inside of the rear windows, take care not to scratch or damage electric heating wires or junctions.

## A/C Control Panel, Vehicle Speakers, Dashboard, Control Panel and Switches

- Clean the A/C control panel, vehicle speakers, dashboard, control panel and switches with a wet soft cloth.
- Wipe dust off gently with a clean soft cloth soaked in water or lukewarm water.

### CAUTION

- Do not use any organic substance (such as solvents, kerosene, alcohol, and gasoline) or acid-base solutions. These chemicals can cause discoloration, staining, or flaking.
- Confirm that the detergent or polishing agent to be used does not contain the above substances.
- If a new-type liquid car washer is used, do not splash it onto the interior surface of the vehicle, because it may contain the above substances. Clear any splashed liquid quickly.

## Leather

- Leather trimmings can be cleaned with a neutral detergent for woolen.
- Use a soft cloth with a neutral detergent solution to wipe off the dust, and then use a clean, wet cloth to wipe the remaining detergent thoroughly.
- If leather gets wet, wipe it with a clean soft cloth. Dry the leather in a well-ventilated, cool place.
- For any questions about vehicle cleaning, please consult a local BYD authorized dealer or service provider.

### CAUTION

- If dirt cannot be cleaned off using a neutral detergent, clean it with a detergent that does not contain organic solvents.
- Do not clean leather with any organic material such as volatile oil, alcohol, gasoline, or acid-base solution, as these will cause discoloration.



### CAUTION

- Do not clean leather with a nylon brush or synthetic fiber cloth, as these may scratch the fine patterns on the leather surface.
- Mold may grow on dirty leather trimmings. Special care must be taken to avoid oil stains, and trimmings must always be kept clean.
- Prolonged exposure to sunlight will cause leather to harden or shrink, so the vehicle should be parked in a shady and cool place, especially in the summer.
- In hot weather, avoid placing vinyl or waxy items on the trimmings, as these may stick to leather in high temperatures.
- Improper cleaning of leather trimmings may cause discoloration or spots.

## Self-Maintenance

### Self-Maintenance

#### Self-Maintenance Precautions

- If maintenance is to be carried out by the owner, be sure to follow the correct steps specified in this section.
- Note that improper and incomplete maintenance will affect the use of the vehicle.
- This section only lists instructions on simple maintenance items that can be done by the owner. However, there are many items that must be done by qualified technicians with special tools.

- Special care must be taken in maintaining vehicles to prevent accidental injuries. Make sure to obey the followings:



### CAUTION

- Beware of short circuits, as some circuits and vehicle components carry high current or voltage.
- If coolant overflows, wipe it with a dry cloth or tissue to prevent damage to components or vehicle paint and add coolant in time.
- Only specified spark plug can be used. The use of other spark plug may result in engine performance loss or damage, or radio interference to other electric products.
- Do not reuse the spark plug by cleaning or adjusting the spark plug gap.
- If any brake fluid overflows, rinse it with water to prevent damage to components or vehicle paint.
- Do not drive the vehicle with the air filter removed, otherwise, the engine will be excessively worn.
- When replacing wiper blades, do not allow the wipers to scratch the glass surface.
- Before closing the engine cover, check whether any tool or wipe cloth is left in the engine compartment.
- When the engine is running, keep hands, clothes and tools at a certain distance from the rotating fan. It is recommended to take off the watch, ring, or tie.
- The engine, radiator, exhaust manifold and spark plug cover are hot after driving. Do not touch



## CAUTION

them and be careful to operate. The engine oil and other fluid may be hot too.

- If the engine is very hot, do not remove or loosen the expansion tank cover or remove the water pump to prevent burns.
- Do not smoke in or near the vehicle to avoid sparks or open flames that may cause fire.
- Ensure the vehicle is turned off when working around the electric fan or radiator grill. If the engine coolant is hot or the A/C System is on with the vehicle powered on, the electric fan may automatically start.
- When working inside or under the vehicle, always wear goggles to protect your eyes against flying or falling objects or splashing liquid.
- As brake fluid may damage the skin or eyes, be careful when filling it. If your skin or eyes are exposed to brake fluid, immediately flush with clean water. Seek medical attention immediately if discomfort persists.

## Self-check

The following items should be checked according to usage or specified mileage:

- Coolant level: The radiator expansion tank should be checked monthly.
- Windshield washer fluid: The residual amount of washer liquid in the tank should be checked monthly. When washer liquid is frequently used, the residual amount of liquid should be checked more often.

- Windshield wiper: Check the wiper condition monthly. If the wiper does not work, check it for wear, cracking, or other damage.
- Brake fluid level: Check the level monthly.
- Brake pedal: Check whether the brake pedal can be operated freely and whether the brake light switch limiting pad is aged or damaged.
- EPB switch - Check whether the switch is functional.
- Low-voltage battery - Check battery conditions and check for terminal corrosion monthly.
- A/C system - Check the operation of A/C units weekly.
- Tires - Check tire pressure monthly. Check tread wear and whether there are foreign bodies embedded.
- Windshield defrosters - Check the defroster vent monthly.
- Lights: Check the condition of headlights, position lights, tail lights, high mount brake light, turn signals, rear fog lights, brake lights and license plate light monthly.
- Doors: Check whether the tailgate and all other doors (including rear doors) can be opened freely and locked securely.
- Horn: Check whether the horn is functioning properly.



## REMINDER

- Do not continue driving a vehicle that has not been inspected, as this may result in serious vehicle damage and personal injury.

## Lights

### Headlight adjustment

- Headlights are aligned before vehicle delivery. If the vehicle carries heavy load frequently, headlights may need to be realigned. It is recommended to have the headlights aligned by a BYD authorized dealer or service provider.

### Fogging of lights

- Combination lights, tail lights, and turn signals on the side mirrors may become foggy after heavy rain or cleaning. This is similar to condensation on the side window during rain. It does not mean any problem with your vehicle.
- The lights are in a relatively enclosed and narrow space. The temperature is very high when they light up (the mask and reflector could be burned and deformed easily), so they need heat dissipation. There are heat dissipation holes on the lamp housing for convection. The greater the temperature difference is, the more active the convection is. During the convection, the moisture in the air inevitably enters a lamp. Factors such as exposure to sunlight, convection, and bulb heating can cause the moisture in the air to condense into fog or water beads easily on the lamp surface at low temperatures. This is called fogging of lights.

### WARNING

- The headlight bulb becomes very hot when illuminated. Grease, sweat, or scratches on the surface of the bulb glass cause the bulb to overheat and break.

### REMINDER

- If fog presents inside the headlight and inside the turn signals on side mirrors, it may be due to high air humidity or significant temperature difference between the vehicle and its surroundings. In that case, turn on the headlight or turn signal while driving. The fog will evaporate after a short period of driving.
- If there is a noticeable amount of water inside the lights, it is recommended to drive the vehicle to a BYD authorized dealer or service provider for maintenance.

## Vehicle Storage

- If the vehicle needs to be parked for a long time (more than a month), the following preparations should be made. Proper preparation helps prevent vehicle degradation and ensure easy reuse of the vehicle. If possible, park the vehicle indoors.
- Refuel in time.
- Thoroughly clean and dry the body surface.
- Clean the interior of the vehicle to ensure that carpets and mats are completely dry.
- Set the gearshift lever in parking gear.
- If the vehicle needs to be stored for a long time, jack up the vehicle body to keep the tires off the ground.
- Open one window slightly (if the vehicle is stored indoors).
- Disconnect the negative terminal of the low-voltage battery.

- Pad the front wiper arm with a folded towel or cloth to keep it out of contact with the windshield.
- To reduce adhesion, apply silicone lubricant to seals of tailgate and all doors and body wax to the painted surface where the seals of tailgate and all doors meet.
- Cover the body with a breathable covering made of a "porous material" such as cotton. Non-porous materials such as plastic cloth accumulate moisture and damage the body surface paint.
- If possible, start the engine for a while regularly (preferably once every month). If the vehicle has been parked for a year or more, go to a BYD authorized dealer or service provider for comprehensive maintenance.

## Hood

### Opening the Hood

1. Pull the handle on the right under the dashboard twice. The hood unlocks and opens slightly.



2. Raise the hood to an appropriate height; then it will automatically rise to the open state.



### Closing the Hood

1. Pull the hood down to a certain height, push it down with a little force until it is half-locked, and then slowly press the blue area in the picture with both hands until the hood is fully locked and closed. Keep your hands at a certain distance and do not press the lines.

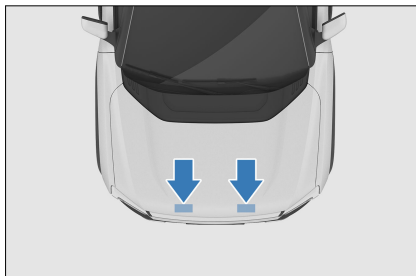

2. After closing the hood, check whether the latch is securely locked.



#### REMINDER

- Ensure that the hood is closed and locked firmly. Otherwise, the hood may suddenly open during driving, resulting in an accident.
- Do not force down the hood.
- Do not close the hood with one hand, as this may concentrate the force in one area and cause damage to the hood.





## REMINDER

- Do not press the front edge of the hood to prevent damage to the vehicle.

# Engine

## Engine Maintenance Information

- If the engine is not started for a long time, the carbon tank will be saturated, causing the risk of fuel leakage, so the carbon tank needs to be desorbed regularly.
- If the vehicle is driven in EV mode for a long time, this function starts the engine and exits until the carbon tank load meets the requirements.

## Engine Cylinder Cleaning

In severe cold areas, failure to start the engine may cause engine cylinder flooding, so it is necessary to carry out cylinder cleaning:

1. When the OK indicator stays on, the vehicle is in ECO mode, and the engine is not running, manually switch to Neutral.
2. Pull and hold the EV/HEV switch, press the brake and accelerator pedals to the deepest positions at the same time, and wait for several seconds to activate the cylinder cleaning.

## Engine Oil

- Be sure to use engine oil with right specifications.
- When purchasing engine oil, check the oil specifications marked on the packaging container, which must conform to the using regulations for this vehicle.

## Recommended engine oil

- Engine oil plays an important role in ensuring the performance and service life of the engine, so high-quality purified engine oil should be used. It is recommended that you choose BYD original engine oil.
- Engine oil consumption is related to driving habits, weather conditions, and road conditions. The engine oil consumption rate of new engines may be higher.

## Check engine oil

1. Park the vehicle on a level road, start the engine till it reaches the normal working temperature, and then shut down the engine.
2. After shutdown for 10 minutes, remove the cover plate on the right side, pull out the oil dipstick, observe the oil level and oil condition, and check whether the oil level is between ① and ②. Add or replace oil as required.
3. Insert the oil dipstick back.

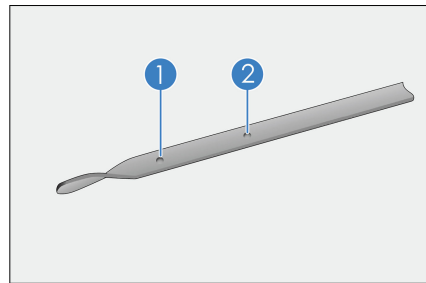

- When the low oil pressure warning light illuminates, please add oil in time.



## WARNING

- Be careful not to splash oil on other vehicle components.

## WARNING

- The engine oil, engine components, and exhaust system are high-temperature components, which may cause burns. Be careful and wear protective clothing when working in the front compartment.
- Long-time or frequent contact with used engine oil causes skin diseases. Use soapy water and clean water to wash the oil on the skin.

## Cooling System

- It is required that the liquid level should be between the Maximum (MAX) and Minimum (MIN) marker lines of the expansion tank.

Engine coolant expansion tank

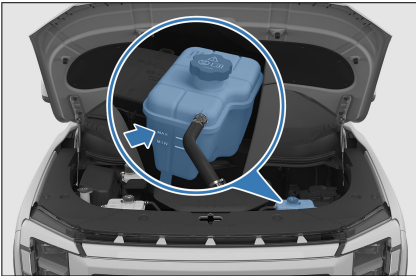

Motor controller coolant expansion tank

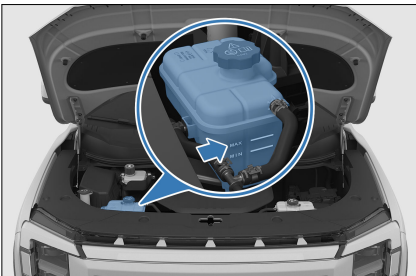

- Improper coolant may damage the cooling system.
- Use coolant of the same type as the one used originally. Fill up proper coolant into the cooling system based on the ambient temperature.
- Do not add any admixture.
- Different brands and types of coolant should not be mixed.

## CAUTION

- Do not use tap water, so as to avoid cooling system damage.
- To avoid incompatible coolants and additives, do not apply additives like rust remover to the cooling system.

## Radiator and Condenser

If the radiator and condenser are dirty or in uncertain conditions, it is recommended to bring the vehicle to a BYD authorized dealer or service provider.

## REMINDER

- Do not touch the radiator or condenser when the engine is hot to prevent scald.
- Do not operate by yourself, or the radiator and condenser may be damaged.

## Electric Fan

- If the vehicle is driven in desert, mud, and other special road conditions for a long time, mud, sand, and other foreign matters will intrude into the electric fan. It is recommended to clean and maintain the electric fan in time, otherwise, it may cause abnormal vibration and noise, affecting driving comfort and even

damaging the electric fan in serious cases.

### CAUTION

- The cleaning and maintenance of the electric fan is recommended to be performed by professionals from a BYD authorized dealer or service provider. When cleaning the fan with an air gun or water jet, pay attention to the following:
  - Before cleaning the fan, ensure that the vehicle is cold (or has been parked for 30 minutes) and powered off.
  - When cleaning the fan with a water jet, try to avoid direct water flow to the fan connectors and other harness interfaces/connectors.
  - After the fan is cleaned, use a dry towel to clean the residual water stains on the harness interfaces/connectors in time.

## Braking System

- Check the level in the fluid tank monthly, and change the brake fluid according to the travel time and mileage specified in the maintenance schedule.
- Be sure to use the brake fluid of the same specifications as the original brake fluid, and different types of brake fluid cannot be mixed.
- It is required that the level in the fluid tank should be between "MAX" (maximum level) and "MIN" (minimum level) marks.
- If the level is at or below the MIN mark, check if the braking system leaks and the brake friction blocks are worn.

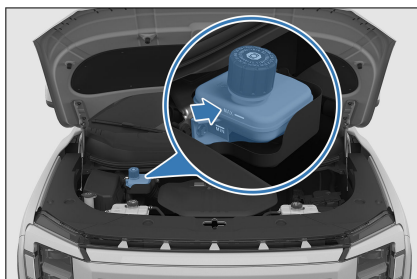

## Washer

- The windshield washer reservoir is located behind the right headlight in the engine compartment. Remove the cover to check the fluid level in the reservoir.
- In bad weather, if the windshield washer is used frequently, the level of the washer reservoir should be checked more frequently.
- High quality windshield washer fluid should be added to improve stain removal and prevent freezing in cold weather.

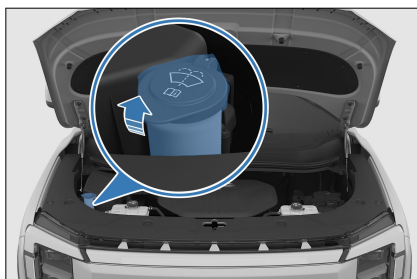

- When refilling the washer fluid, use a clean cloth dipped in the windshield washer fluid to clean the windshield wiper blade. This helps keep the wiper blade in good condition.
- During normal use, check the liquid level of the windshield washer reservoir at least once a month.

 **CAUTION**

- Do not inject vinegar-water solution into the windshield washer fluid reservoir.
- It is recommended to use certified windshield washing fluid.

## Fuel Filter

Replace the fuel filter according to the travel time and mileage specified in the maintenance schedule.

- When the fuel is dirty or contaminated, it is recommended to replace the fuel filter every 10,000 km or six months, as the filter is more likely to be blocked.
- It is recommended to replace the fuel filter at a BYD authorized dealer or service provider. Because there is pressure in the fuel system, if all the oil lines are not properly handled, the fuel may spill out and cause danger.
- If you have used more than one barrel of impure fuel, the filter should be changed earlier.
- If the filter is blocked by dirt, it is recommended to contact a BYD authorized dealer or service provider for inspection or replacement of the filter.

## A/C System

- The A/C system is a closed system, and any important maintenance work should be performed by professionals from a BYD authorized dealer or service provider.
- The following practices help ensure that the A/C system works effectively.
  - Check the radiator and A/C condenser regularly. Remove leaves,

insects, and dust from the front surface. These deposits hinder the airflow and reduce the cooling effect. It is recommended to contact a BYD authorized dealer or service provider for handling.

- In cold months, turn the A/C on once a week for at least 10 minutes to circulate the lubricating oil in the refrigerant unit.
- If A/C cooling efficiency decreases, go to a BYD authorized dealer or service provider for maintenance.

 **CAUTION**

- Whenever the A/C system is maintained, the maintenance station should use a refrigerant recycling system.
- The system can recycle refrigerant to avoid environmental pollution caused by directly discharging refrigerant.

## Wiper Blades Maintenance

The blade strip, made of synthetic rubber, is a vulnerable part. Various service environment of the vehicle and usage habits of drivers can damage the blades. Therefore, please observe the following to ensure the service life of blades and driving safety:

- Do not use a blade to remove ice from the windshield surface. Use a customized ice scraper.
- Do not scrape the windshield surface if it is dirty, greasy or waxy.
- Keep the windshield surface clean. Do not scrape dust, sand, insects, or foreign bodies on the windshield surface.

- During vehicle washing and body paint maintenance, there is no need to wax the windshield, as the wax layer reflects light in bad light, affecting the line of sight and driving safety. After washing the vehicle, rinse the blade with plain water, and use special windshield wax cleaner to remove the wax layer on the windshield.
- To prevent excessive water pressure from damaging the blades, do not wash the blades directly with a water jet.

### Maintenance Rules

- Clean windshield and blade regularly (preferably once a week or once every two weeks).
- Wipe the wiper regularly (preferably once a day or once every two days) even if it doesn't rain.
- When using a blade to wipe the windshield, keep the windshield fully wet (when there is no rain, the washer liquid must be sprayed in advance).
- Clean the windshield with a special windshield washer fluid.
- Promptly clean mud and insect carcasses stuck to the windshield with a rag.
- When there are marks on the windshield caused by gravel, maintenance should be carried out timely (it is recommended that windshield repair resin products should be used and the windshield should be replaced if marks are too large or too many.)
- Replace the wiper blades regularly, preferably once every six months.
- When cleaning the windshield, raise the wiper arm in advance. The specific operation method is as follows:

1. Go to infotainment touchscreen  
→Service to enable front wiper maintenance. The wiper is then rotated down.
2. Grasp the upper end of the wiper arm and carefully lift the wiper arm and blade assembly.

## Tires

- For safe driving, tires must be made and sized to fit the vehicle, with good tread and standard tire pressure.
- The following pages provide details on how to check tire pressure, damage to and wear of tires, and the operating method for tire rotation.

### WARNING

- Using tires with excessive wear or insufficient/excessive pressure can result in accidents, severe injury, or death.
- Please follow all instructions in this manual regarding tire inflation and maintenance.

### Tire Inflation

- Keep tires properly inflated to provide the best combination of maneuverability, tread life, and driving comfort.
- Under-inflated tires can cause uneven tire wear, affect maneuverability and energy consumption, and are prone to leakage due to overheating.
- Over-inflated tires reduce riding comfort and are prone to damage from uneven roads. In severe cases, the risk of tire bursting poses severe threats to the safety of the entire vehicle. Over-inflation will also cause uneven wear of tires, affecting tire service life.

- The vehicle is equipped with a tire pressure monitoring device. When tires are cold, you can decide whether to replenish tire pressure according to the tire pressure values displayed on the instrument cluster.
- Tire pressure should be measured while tires are at ambient temperatures. This means that it should be measured at least three hours after stopping the vehicle. If you must drive the vehicle before the tire pressure is measured, tires can still be considered at ambient temperatures as long as the traveled distance is not more than 1.6 km.
- It is normal that tire pressure readings measured when tires are hot (after travel of several kilometers) are 0.3–0.4 bar higher than those when tires are cold. In that case, do not deflate tires in order to achieve the specified cold tire pressure reading, otherwise, the tire pressure will be insufficient.

#### **!** REMINDER

- The recommended cold tire pressure is indicated on the label affixed to the driver's door frame.
- Tubeless tires can self-seal punctures. However, as leakage is usually very slow, the leaks should be carefully identified as soon as the tire begins to depressurize.

#### **Tire Inspection**

- Whenever checking tire inflation, check tires for damage, foreign body piercing and wear.
  - Replace the tire if bumps, or tread or side damage are found. Tires must be replaced if any of the case happens.

- Replace the tire if there are cracks on its side or if its fabric or cord can be seen.
- Replace tires with excessive tread wear.

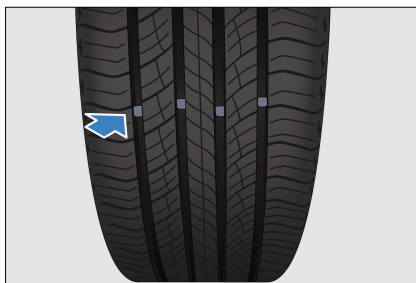

- Wear marks are cast inside tire treads. When the tread is worn at this point, a band mark is shown across the tread, indicating the tread thickness is less than 1.6 mm. The adhesion of tires worn to this extent is very small on wet roads.
- When the tread is worn to the point where the wear mark is exposed, there is serious performance loss, and the tires must be replaced.

#### **Maintenance**

- In addition to proper inflation, proper wheel alignment also helps reduce tread wear.
- If uneven tire wear is found, go to a BYD authorized dealer or service provider to check the wheel alignment.
- Although the vehicle has been balanced in the factory, it may need to be re-balanced after running for a period of time.
- If there is some kind of continuous vibration at high vehicle speeds (above 80 km/h), but not at low vehicle speeds, go to a BYD authorized dealer or service provider for tire checks.

- If a tire has been repaired, be sure to re-balance it.
- After installing a new tire or replacing a new wheel, always perform tire balancing.

### **! CAUTION**

- Improper wheel balancers can become loose and fall off, which damages the vehicle or surrounding objects during vehicle travel.
- Improper wheel balancers damage the aluminum rims of the vehicle. Therefore, it is recommended to use original wheel balancers to keep balance.

### **Tire Rotation**

- In order to make tires wear the same and prolong their service life, it is recommended to regularly (no more than 10,000 km) check the wear of the tire inner and outer tread and rotate the tires and conduct four-wheel alignment, inspection and adjustment if necessary.
- Do not rotate tires when a spare tire is used for the vehicle.
- After tire replacement, go to a BYD authorized dealer or service provider for tire pressure matching.

### **Directional tires and wheels**

- When purchasing replacement tires, you may find that some tires are "directional", which can only be rotated in one direction. If directional tires are used, only the front and rear wheels can be swapped in tire rotation.
- Tire rotation for four-wheel drive vehicles is as shown:
  1. Non-directional tires and wheels

### 2. Directional tires and wheels

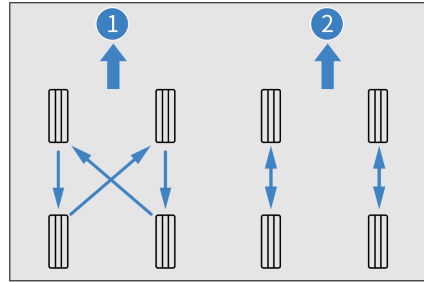

### **! WARNING**

- Only the left and right wheels can be rotated due to the narrow front and wide rear tires on rear-wheel drive vehicles. If directional tires are used on rear-wheel drive vehicles, tire rotation is not accessible.

### **Replacing Tires and Wheels**

- Original tires maximize vehicle performance, while providing the best combination of maneuverability, driving comfort and service life.
- It is recommended to go to a BYD authorized dealer or service provider for replacement for new original tires.
- Replacement of radial tires with different sizes, loads, rated rotate speeds and maximum cold pressures (marked on the tire side) or mixed use of radial tires and diagonal tires reduces braking ability, driving force (ground adhesion) and steering accuracy.
- The installation of unsuitable tires can affect the operational sensitivity and stability of the vehicle, and may lead to accidents.
- It is better to replace four tires at the same time. If it is impossible or unnecessary, replace the pair of

front tires or rear tires at the same time. Do not replace only one tire; otherwise it will seriously affect the maneuverability of the vehicle.

- ABS works by comparing the rotate speed of tires. When replacing a tire, use a tire of the same size as the original tire. The size and structure of the tire affect wheel speed and may lead to uncoordinated system operation.
- If the wheels need to be replaced, make sure that the specifications of the new wheels are consistent with those of the original ones. New wheels are available for purchase at BYD authorized dealer or service providers. Please consult a BYD authorized dealer or service provider before replacing the wheels.

### **WARNING**

Please observe the following precautions to ensure proper vehicle performance and control.

- Do not mix radial tires, bias belted tires, or diagonal ply tires on the vehicle.
- Do not use tires with dimensions other than those recommended by the manufacturer.

## Fuses

All vehicle circuits are provided with fuses to prevent short circuit or overloading.

- The under-hood fuse box is located beside the left fender of the engine compartment.
  - Remove the upper cover of the front compartment fuse box, and turn over it to view the fuse box label.

- The dashboard fuse box is located in the shield under the dashboard.
- The positive fuse box is under the rear seat and above the low-voltage battery.

### **REMINDER**

- Do not use fuses with amperage higher than the rated ampere value or any other object to replace fuses, as this can cause serious damage or even a fire.
- If a fuse blows, it is recommended to check or replace the fuse at a BYD authorized dealer or service provider.
- Replacement of blown fuses with ones of higher amperage can significantly increase the likelihood of damage to the electrical system.
- If there is no spare fuse with an amperage matching the circuit, use a fuse with lower amperage instead.



# 07

## **WHEN FAULTS OCCUR**

When Faults Occur.....212

# When Faults Occur

## Reflective Vest

In case of a sudden breakdown during driving, if you need to get out of the vehicle urgently to check for faults or handle accidents, always wear the reflective vest properly before that to ensure your safety.

## If Smart Key Battery Is Exhausted

If the smart key indicator does not flash and the vehicle cannot be started by the start function, the smart key battery may be exhausted. It is recommended to contact a BYD authorized dealer or service provider for battery change as soon as possible. In this case, you may start the vehicle in no power mode.

### CAUTION

- Do not place the smart key in a position exposed to high temperatures.
- Do not hit or slam the key with hard objects.
- Magnetic fields generated by nearby radio stations, substations or airport radio transmitters may interfere with the normal operation of electronic smart keys.
- After locking the vehicle and arming its anti-theft alarm system, keep the key away from the vehicle if you do not use the vehicle; otherwise the automatic card finding function of the vehicle will consume the power

### CAUTION

of the low-voltage battery and the smart key.

1. Use the mechanical key to unlock the vehicle.
2. Put the smart key close to the no-power sign on the auxiliary dashboard.
3. Press the START/STOP button and the brake pedal to start the vehicle.

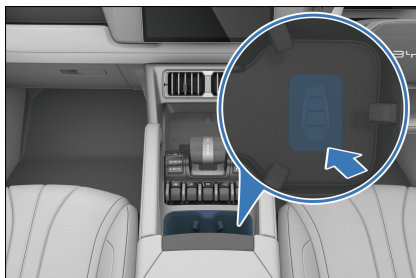

## If a High Voltage Fault Occurs

If the vehicle breaks down and the message "LVPS failure, please stop immediately and contact service shop" is displayed on the instrument cluster, immediately stop safely and contact a BYD authorized dealer or service provider to deal with it.

## If the Vehicle Cannot be Powered on

### Simple Checks

Before the inspection, make sure that the vehicle is started according to the correct starting procedures (see "**P.120**") and check whether the fuel is sufficient. At the same time, check whether the vehicle can be started with the spare key. If it

can be started, the original key may have been damaged. In this case, have the key checked by a BYD authorized dealer or service provider. If all keys cannot be used, the key or smart key system may fail. In this case, contact a BYD authorized dealer or service provider.

#### **If the engine runs too slowly or fails:**

1. Check whether the low-voltage battery connectors are tight.
2. If the battery connectors are normal, turn on the front interior lights. If the interior lights do not turn on or are dim, the low-voltage battery is low. In this case, it is recommended to contact a BYD authorized dealer or service provider. If the interior lights are on but the engine does not start, it is recommended to contact a BYD authorized dealer or service provider.

#### **If the generator drives the engine to run at normal speed but the engine cannot run:**

1. Restart the vehicle.
2. If the engine cannot be started, the cause may be engine oil spillage due to repeated starts, failure of the BMS battery manager module, or failure of starting-related modules such as the generator module.
3. If the engine still cannot be started, adjustment or repair is required. In this case, it is recommended to contact a BYD authorized dealer or service provider.

#### **Starting the Engine with Oil Spillage**

- If the engine cannot be started, the cause may be engine oil spillage due to repeated starts.
- If the engine is flooded, the following operations can be performed manually:

1. When the OK indicator stays on, the vehicle is in ECO mode, and the engine is not running, manually switch to Neutral.

2. Press the brake and accelerator pedals to the deepest positions at the same time, and wait for several seconds to activate the cylinder cleaning.

- If the engine has been started for 5 seconds and still cannot start, wait for several minutes and start it again.
- If the engine still cannot be started, adjustment or repair is required. In this case, it is recommended to contact a BYD authorized dealer or service provider.



#### **REMINDER**

- If the engine fails to start continuously, and the prompt "Engine start failed, please drive to safe area and stop to check" is displayed on the instrument cluster, it is recommended not to restart the engine, otherwise the generator and wiring system will overheat.

### **If the Engine Fails to Start While Driving**

- Maintain the lane position and gradually slow down the vehicle. Carefully drive the vehicle off the road to a safe place.
- Turn on the hazard warning light.
- Try to restart the engine.

## If the Engine Is Overheated

If the high engine coolant temperature warning light turns on and power loss is found, it indicates that the engine is overheated, and the following procedures should be followed:

1. Drive the vehicle away from heavy traffic and park it in a safe place. Turn on the hazard warning light, engage the EPB, and press the "P" button. If the A/C is used, turn off the A/C and place a warning triangle at the corresponding position behind the vehicle according to the regulations.
2. If the "high engine coolant temperature" warning light turns on, stop the engine. If there is a sound and the coolant sprays out in the engine compartment, open the engine hood after the steam disappears. If no coolant is sprayed, confirm whether the cooling fan is working before and after the engine stops. If the fan is not working, turn off the power.



### REMINDER

- To avoid personal injury, keep the hood closed until no coolant flows out. The flow of coolant indicates high pressure.

3. Check the radiator, hose and vehicle underneath for obvious coolant leakage.



### WARNING

- When the engine is running, keep hands and clothes at a certain distance from the rotating fan and engine pulley.

4. In case of coolant leakage, stop the engine immediately and contact a BYD

authorized dealer or service provider for help.

5. If there is no obvious leakage, check the coolant expansion tank. If coolant is insufficient, be sure to open the expansion tank cover after the engine coolant temperature drops to the normal value. When the engine is running, add coolant into the expansion tank to the upper scale mark, tighten its cover, and start the engine for two to three cycles (start the fan without turning on the A/C). After the coolant temperature drops to the normal value, check the coolant level again. If necessary, add more coolant to the appropriate scale. A serious loss of coolant indicates a leakage in the system. In this case, contact a BYD authorized dealer or service provider for inspection immediately.



### WARNING

- To avoid serious injury caused by high-temperature steam and liquid ejection, do not open the expansion tank cover when the engine and radiator are hot.

## If the Vehicle Needs Towing

If the vehicle needs to be towed, contact a BYD authorized dealer or service provider, a professional towing service, or a roadside assistance service, if there is prior membership.



### CAUTION

- Do not allow other vehicles to pull your car with only ropes or chains.

Recommended towing method:

- Flatbed device

- If the vehicle fails and needs towing, a flatbed is recommended. When the vehicle is being towed, keep its four wheels off the ground. Towing the vehicle on front or rear wheels alone may damage high-voltage components.

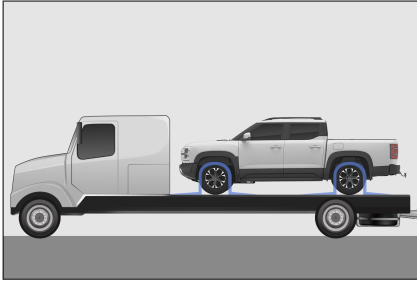

**CAUTION**

- When moving a vehicle on a flat trailer, make sure that the vehicle being moved is properly secured to prevent it from sliding back.
- It is recommended to use professional tie-down straps and tensioners, and employ the over-the-wheel method to secure the vehicle.
- When fixing the vehicle, do not pass the fixtures such as straps and ropes through the wheels or tie them on the chassis, suspension and other body parts to prevent damaging the vehicle.
- Ensure the vehicle's wheels are immobilized during transport to prevent potential damage.

**Tow Eye**

- The front tow eyes are below both sides of the front bumper, as shown in the illustration.



- The rear tow eyes are below both sides of the rear of the vehicle, as shown in the illustration.

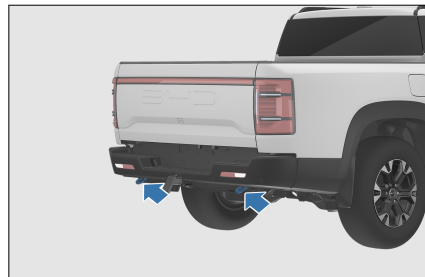

- To rescue a stuck or high-centered vehicle, call a professional rescue or the customer service number.
- In emergency situations where you have to free the vehicle by yourself or rescue other trapped vehicles by using the tow eye, observe the following to avoid vehicle damage or personal injuries.
  - The towed vehicle must be controlled by a driver inside the cabin, with the steering and braking systems in normal conditions.
  - The towed vehicle must not carry any person except for the driver or tow any trailer.
  - The towed vehicle must be in Neutral.
  - The width and weight of the towed vehicle must not be greater than those of the towing vehicle.

- The distance between the towing and towed vehicles must be more than 4 meters but less than 10 meters.
- Both towing and towed vehicles must have their hazard warning lights on.
- The towing vehicle must be in good conditions, with a tow speed no more than 5 km/h.
- Never use jerking actions to pull the vehicle.
- When towing the vehicle, ensure its surroundings are unobstructed and have enough space and no person is close to the towing device.
- When freeing the vehicle, control to make it travel in the direction of tow force. Dragging the vehicle from the side or vertically is prohibited.
- Only the vehicle tow eye can be used, and use it correctly.

#### REMINDER

- If the steering or braking system of the towed vehicle fails, contact a professional rescue or call the customer service number. Do not tow the vehicle directly.

## If a Tire Goes Flat

- In case of a flat tire, slow down, keep straight, and drive off the busy road to a safe place.
- Park on solid, flat ground and avoid motorway forks.
- Press the "P" button to engage the EPB.
- Power off the vehicle and turn on the hazard warning light.

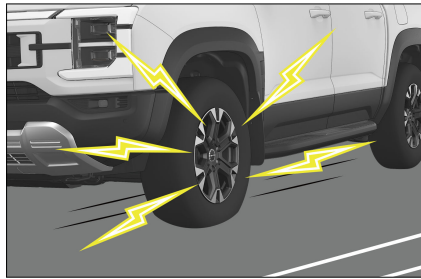

- Be sure to have all passengers get off the vehicle and ask them to go to a safe place away from crowded traffic.
- To prevent slipping, secure the vehicle by wedging the tire diagonally against the flat tire.

#### CAUTION

- Do not continue driving with a flat tire. Even a short distance of driving with flat tire can cause irreparable damage.

### In-Vehicle Tools

The tools are stored under the seatback of the rear seats and in the glove box in front of the front passenger's seat. In-vehicle tools include reflective vest, warning triangle, jack, jack rocker, wheel wrench, and lug nut cap removal clamp.

#### REMINDER

- In an emergency where you need to service the vehicle yourself, you must know how to use these in-vehicle tools and their locations.

### Placing the warning triangle

#### REMINDER

- When parking for repair, remember to place the red

## ! REMINDER

triangle side facing oncoming vehicles, 100-200 meters away from the vehicle. After the repair, recover the warning triangle for future use.

The warning triangle is used to warn vehicles coming from behind and to avoid collisions due to high speed or late braking.

How to use the warning triangle:

1. Take the warning triangle out of its box.
2. Attach the ends to form a triangle.
3. Mount the supports as shown.



## Using the Spare Tire

### Spare Tire Positions

- The spare tire is located below the crossbar under the rear of the pickup bed. Adjust the spare tire lifter with a jack rocker and wrench to make the spare tire fall slowly, and then take out the spare tire.

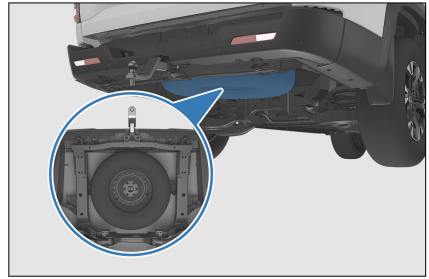

### Taking out the spare tire

1. Take out the tool kit, assemble the three parts of the rocker together as required, and insert the thick end of the rocker into the hole of the wrench.

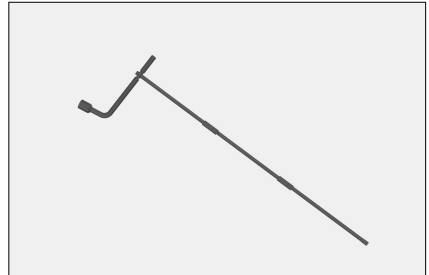

2. Thread the thin end of the rocker through the hole above the license plate on the tail beam and insert it into the waist-type groove of the drive shaft.

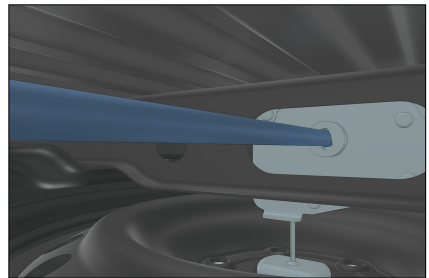

3. Rotate the rocker counterclockwise by hand to get the spare tire down.
4. After the spare tire falls to the ground, continue to rotate the rocker counterclockwise until the action cannot

be performed, indicating that the wire rope is fully released.

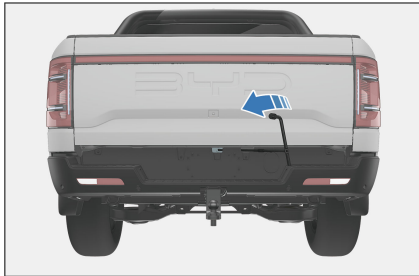

5. Remove the spare wheel tray from the spare wheel hub.

6. Take out the spare tire.

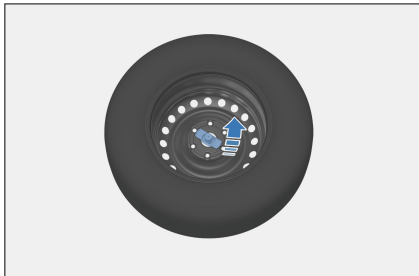

### Store the flat tire

1. Put the flat tire at the place where the spare tire is removed, and tilt the spare tire tray over the center of the tire hub.

2. Rotate the rocker clockwise manually to lift the flat tire until two clicks are heard or the second release of force is felt, indicating that the flat tire is stored properly.

### CAUTION

- Use the in-vehicle wheel wrench to tighten the retaining nut of the flat tire.

### Replacement of the Spare Tire

#### Wedging the wheel

1. Wedge the tire diagonally against the flat tire to prevent the vehicle from rolling.

- To do so, place the wedges in front of the front wheels or behind rear wheels.



#### Loosening lug nuts

2. Remove the decorative cover of lug nuts with the lug nut cover removal clamp in the glove box.

3. Loosen all the lug nuts on the flat tire.



- Loosen lug nuts before raising the vehicle.
- Loosen the nuts by turning them anticlockwise.



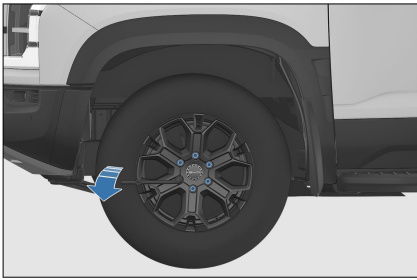

**! REMINDER**

- Hold the end of the wrench handle and press it down, and do not allow it to slide off the nut.
- Do not remove the nut, and just loosen it by one to two turns.

**! WARNING**

- Do not apply engine oil or lubricant on bolts or nuts, Otherwise, loose nuts would cause the wheel to come off, causing serious accidents.

**Positioning the jack**

4. Position the jack at the correct jacking point as shown.

- Ensure that the jack is placed on a flat and solid ground.



**! WARNING**

- When you jack up the vehicle, observe the following rules to reduce the likelihood of injury:
  - When you jack up the vehicle, do not have any part of your body under the vehicle. Otherwise, personal injury may be caused.
  - Do not power on the vehicle when it is being jacked up.
  - Park the vehicle on flat and solid ground, activate the parking controls and put the gearshift lever in Neutral. If needed, secure the vehicle by wedging the tire diagonally against the flat tire.
  - Ensure that the jack is placed at the correct jacking point. Jacking up the vehicle at an incorrect jack point will damage the vehicle or tip the vehicle off the jack, causing personal injury.

**Jacking up the vehicle**

5. After confirming that the vehicle has no passenger onboard, jack up the vehicle to a height allowing for spare tire installation.

- Installing a spare tire requires more distance from the ground than removing a deflated one.

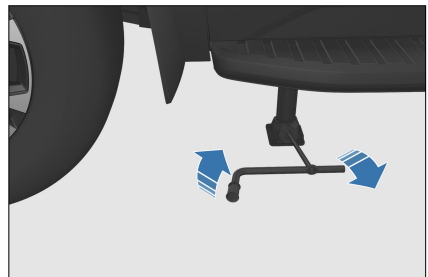

- When lifting the vehicle, insert the jack rocker into the jack (for loose coupling) and rotate it clockwise.
- When the jack is in contact with the vehicle and begins to lift the vehicle, verify again that the jack is in the correct position.

### WARNING

- Never get under a vehicle supported only by a jack.

### Replacing wheels

6. Remove wheel nuts, replace the tire, and place the replaced tire aside. Roll the spare tire to the mounting position, with the bolts aligned with the wheel holes. Then hold up the wheel until the top bolt passes through the screw hole.

- Rotate the tire and push it back until all other bolts pass through the holes.
- Before installing the wheel, remove corrosion from the mounting surface with a wire brush or the like.

### CAUTION

- When you install a wheel, ensure that the mounting position is contacted well, otherwise loose lug nuts will cause the wheel to come off during driving.

### Reinstalling lug nuts

7. Reinstall all lug nuts.

- When reinstalling lug nuts, tighten the lug nuts by hand to the greatest extent, then push the wheel backward and tighten the lug nuts further.

### WARNING

- Do not apply engine oil or lubricant on bolts or nuts, as

### WARNING

this can over-tighten the nuts and thus damage the bolts. The loose nuts so caused would lead the wheels to come off, causing serious accidents.

- If there is engine oil or lubricant on the bolt or nut, it must be removed.
- The conical surface of the nut should be inward. If the nut is installed reversely, it may cause serious accidents.

### Lowering the vehicle

8. Lower the vehicle completely, tighten the lug nuts, and install the decorative cover for lug nuts.

- Lower the vehicle by twiddling the jack lever counterclockwise.

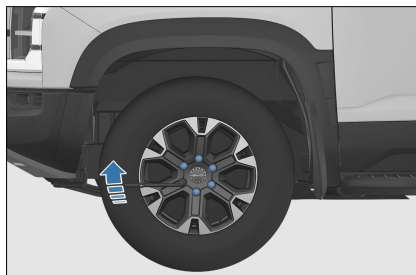

### REMINDER

- Tighten the nuts with a lug nut wrench. Do not use other tools or any lever other than your hands, such as hammers, tubes, or feet.
- Make sure the wrench is securely clamping around the nut.
- Tighten the nuts in the sequence shown, each a bit at a time. Repeat the action until all nuts are tightened.

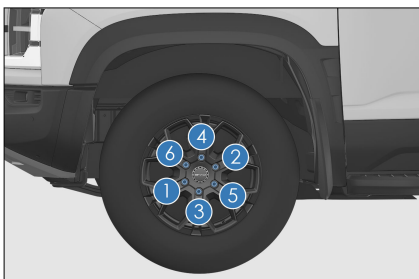

### CAUTION

- Before lowering the vehicle, make sure that no part of your body and no person in the vicinity of the vehicle will be injured by the vehicle's descent.
- Lug nuts must be torqued to 140 N · m after wheel replacement. Otherwise, loose nuts would cause the wheel to come off, causing serious accidents.

### After wheel replacement

9. Check the pressure of the replaced tire.

- Adjust the tire pressure to the specification. If the pressure is lower than the specification, slowly drive to a nearby service station to inflate the tire to the correct pressure value.
- Be sure to mount the tire valve cap; otherwise dust and moisture will enter the valve stem and cause air leakage. If the valve cap is lost, use a new one as soon as possible.

10. Properly store all tools, the jack, and the flat tire.

- Use a torque wrench to tighten all lug nuts to the specified torque value after replacing the wheel.
- Have the flat tire repaired by a technician.



### REMINDER

- Before driving, you should verify that all tools, jacks, and flat tires are kept in a storage area to reduce the possibility of personal injury in case of collision or emergency braking.
- When driving with full-size spare tires, abide by the maximum vehicle speed limit of 80 km/h.
- Do not use the spare tire for a long time. It is recommended to go to a BYD authorized dealer or service provider for tire repair and replacement as soon as possible.



# 08

## **SPECIFICATIONS**

Vehicle Data.....	224
Information.....	228
Declarations of Conformity.....	231

# Vehicle Data

## Vehicle Specifications

### Dimensions

Item	Parameter
Length (mm)	5457
Width (mm, excluding side mirrors)	1971
Height (mm)	1925
Wheelbase (mm)	3260
Front track (mm)	1660
Rear track (mm)	1660
Front overhang (mm)	927
Rear overhang (mm)	1270
Approach angle (°)	31
Departure angle (°)	19.3 (with trailer crossmember)

### Vehicle mass

Item	Parameter
Curb weight (kg)	2710
Front axle load (kg)	1475
Rear axle load (kg)	1235
Max. allowable total mass (kg)	3500
Front axle load at max. allowable total mass (kg)	1595
Rear axle load at max. allowable total mass (kg)	1905
Number of occupants (persons)	5

### Engine

Item	Parameter
Engine model	BYD476ZQF

Item	Parameter
Engine type	In-cylinder direct injection, inline four-cylinder, four-stroke, spark-ignition, water-cooled, double overhead camshaft
Displacement (mL)	1497
Max. net engine power (kW/rpm)	135/5400
Max. torque (N · m/rpm)	260/2000-4800
Emission standard	Euro 5 emission standard

#### Drive motor

Item	Parameter
Model	Front control module: TZ220XYV Rear control module: TZ200XSV
Type	Permanent magnet synchronous motor
Drive type	AWD
Rated power/revolving speed/torque (kW/rpm/N · m)	Front control module: 80/5093/150 Rear control module: 70/4775/140
Peak power/revolving speed/torque (kW/rpm/N · m)	Front control module: 170/18000/310 Rear control module: 150/16000/340

#### Economy and power performance

Item	Parameter
Fuel consumption (L/100km)	7.9
Max. design speed (km/h)	160
Max. gradeability (%)	60

#### Wheels and tires

Item	Parameter
Tire specification	265/65 R18
Tire pressure (bar)	No load: Front wheel: 2.5; rear wheel: 2.5 Full load: Front wheel: 2.5; rear wheel: 2.9

Item	Parameter
Wheel dynamic balance requirement	When installing the adhesive balance weight, the final assembly of wheels shall not be greater than 80g. After the installation, the unbalance shall be less than 10g · cm (single side display of dynamic balancer)

#### Wheel alignment values (at curb weight)

Item	Parameter (no load)
Front wheel camber (°)	-0.17±0.5
Front wheel toe-in (°)	0.11±0.08 (side)
Kingpin caster angle (°)	5.12±0.75
Rear wheel camber (°)	0.89±0.5
Rear wheel toe-in (°)	-0.13±0.08 (side)

#### Braking system

Item	Parameter
Free stroke of brake pedal (mm)	1-5
Front brake disc standard thickness (mm)	34
Front brake disc minimum thickness (mm)	32
Rear brake disc standard thickness (mm)	25
Rear brake disc minimum thickness (mm)	23
Front friction plate standard thickness (mm)	11.5
Front friction plate minimum thickness (mm)	2
Rear friction plate standard thickness (mm)	12
Rear friction plate minimum thickness (mm)	2

#### High-voltage battery

Item	Parameter
Type	Lithium iron phosphate battery



Item	Parameter
High-voltage battery rated capacity (Ah)	81.1

### Seats

Item	Parameter
Forward and backward moving spaces for front seats (cushion depth measured)	60 mm forward from the end
Seatback angle of front seats (cushion depth measured)	24°
Normal service conditions of front seatbacks	24°
Forward and backward moving spaces for rear seats (seat cushion depth measured)	No slide rail
Seatback angle (cushion depth measured)	27°
Normal service conditions of rear seatbacks	27°

### Recommended oil type and amount

Item	Parameter
BYD476ZQF engine oil type	0W-20 and meets the SP specification
	Initial fill: 5.0
BYD476ZQF engine oil amount (L)	Replace engine oil filter: $4.5 \pm 0.15$ Do not replace engine oil filter: $4.2 \pm 0.15$
EHS special transmission gear oil type	EHSF-2LV
EHS special transmission gear oil amount (L)	$5.7 \pm 0.1$
EHS differential gear oil type	Castrol GL-5-80W-90; Total GL-5-80W-90
EHS differential gear oil amount (L)	$1.3 \pm 0.1$
Rear drive electric assembly gear oil type	Castrol BOT384
Rear drive electric assembly gear oil amount (L)	$1.3 \pm 0.1$
Brake fluid type	HZY6
Brake fluid amount (L)	$1.2 \pm 0.2$

Item	Parameter
Engine coolant type	Ethylene glycol antifreeze (-40°C)
Engine coolant amount (L)	8.8±0.5
Motor controller coolant type	Ethylene glycol antifreeze (-40°C)
Motor controller coolant amount (L)	10.1±0.5

**⚠ CAUTION**

- The recommended oil types have been tested and approved by BYD. Using other oil types may affect vehicle performance, and could result in malfunctions or component damage.

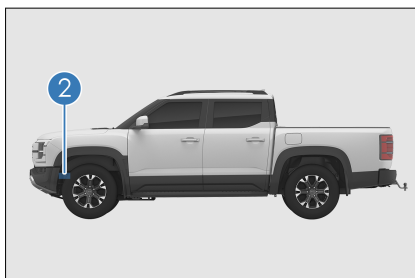

③ Engraved on the lower beam of the front passenger seat.

## Information

### Vehicle Identification

#### Vehicle Identification Number (VIN)

##### Position of VIN attached

① Attached on the sheet metal groove in the lower right corner of the dashboard.



##### Positions of VIN engraved

② Engraved on the outer side of the vehicle's left front longitudinal beam

After connecting the VDS, the VIN can be found in the upper right corner of the screen for the corresponding model. For details, please refer to the VDS operation manual.

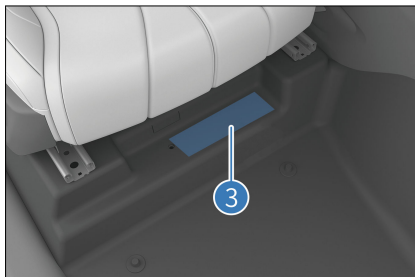

#### Model and Serial Number of Engine and Drive Motor

① The model and serial number of the front drive motor is attached on the upper right part of the hood's inner panel

② The model and serial number of the engine are attached on the engine camshaft box.

③ The model and serial number of front drive motor are engraved on the front drive motor housing.

④ The model and serial number of the engine are attached on the engine intake manifold.

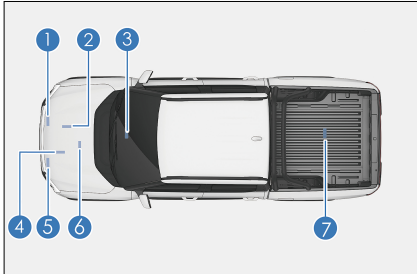

① The model and serial number of the rear drive motor is attached on the upper left part of the hood's inner panel

⑥ The model and serial number of the engine are engraved on the assembly cylinder.

⑦ The model and serial number of rear drive motor are engraved on the rear drive motor housing.

### Vehicle Nameplate

The vehicle nameplate is located under the right B-pillar.

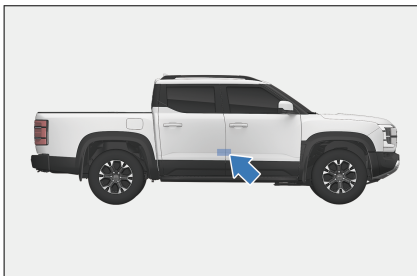

## Warning Labels

Side airbag warning labels are attached below the left and right B-pillar lock rings.

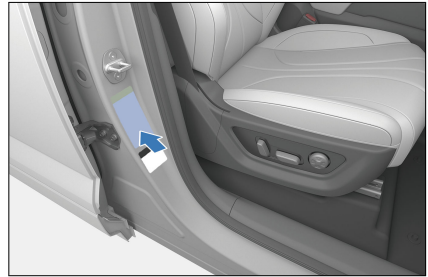

The airbag warning label is printed on the left sun visor.



### **WARNING**

- Never use a rearward facing child restraint on a seat protected by an active airbag in front of it. Death or serious injury to the child can occur.

The tire pressure label is attached below the right B-pillar lock ring.

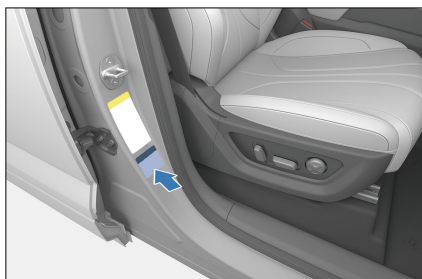

The child protection lock label is engraved on the metal sheet surface on the left/right rear door.



The charging warning label is attached on the upper part of the inner side of the charge port door.



① A/C system and cooling fan label

② Battery position label



The label forbidding luggage on the back is attached on rear seats.

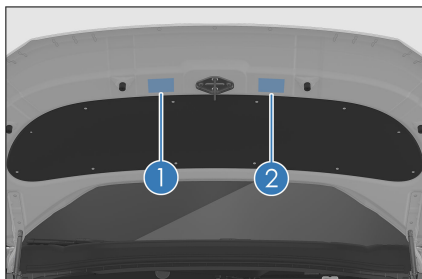

The gasoline indication label is attached on the inner side of the fuel door.



## Transponder Mounting

The transponder mounting position is located in the upper left of the front windshield.



**! CAUTION**

- Do not overlap the sticker transponder with the glass frame or other objects.

## Declarations of Conformity

### Smart Key Certification

---



Uzbekistan

Model: D0-92/D1-92

---



EU countries

Model: D0-92/D1-92

---



Australia/New Zealand

Model: D0-92/D1-92

---



Brazil

Model: D0-92/D1-92

This equipment is not entitled to protection against harmful interference and may not cause interference to duly authorized systems.

---



Japan

Model: D0-315/D1-315

---

### Corner MmWave Radar Certification

---



EU countries

Certificate ID: RED GZES2210019337AT

---



Australia/New Zealand

According to the Australian Radiocommunication standards, product type can be approved by self-declaration and no official type approval number is granted. There is a mutually recognized mark of compliance between Australia and New Zealand, which means RCM is also applicable in New Zealand.

---



Brazil

Certificate ID: 12803-22-14807

This equipment is not entitled to protection against harmful interference and may not cause interference to duly authorized systems.

---



Paraguay

Certificate ID: 2024-05-l-0432

---



EU R10

Certificate ID: E24\*10R06/02\*5295\*00

---

---

TRC: XXXXX

RC-TA-2024-0586

---

### Front MmWave Radars Certification

---



EU countries

Certificate ID: T.2019.04.0003

---



Australia/New Zealand

According to the Australian Radiocommunication standards, product type can be approved by self-declaration and no official type approval number is granted. There is a mutually recognized mark of compliance between Australia and New Zealand, which means RCM is also applicable in New Zealand.

---



Brazil

Certificate ID: 06354-19-12386

This equipment is not entitled to protection against harmful interference and may not cause interference to duly authorized systems.

---



EU R10

Certificate ID: E24\*10R06/02\*4954\*00

---

IFETEL: XXXXX

Mexico

Certificate ID: RLVVE7719-1064

---

### Tire Pressure Monitoring Module

---



Australia/New Zealand

Certificate ID: RCMP22108 001

---



Brazil

Certificate ID: 13741-22-13003

This equipment is not entitled to protection against harmful interference and may not cause interference to duly authorized systems.

---



## Numerics

12V Auxiliary Power..... 183

## A

A/C Control Panel, Vehicle Speakers, Dashboard, Control Panel and Switches..... 198  
Acoustic Vehicle Alert System (AVAS) ..... 157  
Adaptive Cruise Control\* ..... 134  
Adjusting Front Seat with Power... 62  
Adjusting Rear Seat Head Supports ..... 64  
Adjusting the Steering Wheel Manually\* ..... 67  
Airbag Overview..... 15  
Airbag Triggering Conditions and Precautions..... 18  
Anti-lock Braking System..... 167  
Anti-theft Alarm System..... 30  
Automatic Anti-glare Interior Rearview Mirror..... 70  
Automatic Vehicle Hold (AVH)..... 131  
Automatic Vehicle Washing..... 197

## B

Blind Spot Assist (BSA)\* ..... 150  
Brake Fluid..... 205  
Break-in Period..... 101

## C

Carpet..... 197  
Carrying Luggage..... 114  
Center Console Cubby..... 180  
Charging Port Immobilizer System 95  
Charging Precautions..... 81  
Charging Safety Warnings..... 80  
Child Presence Detection (CPD)... 154  
Child Protection Lock..... 60

Child Restraint System Anchorages ..... 22  
Child Restraint Systems..... 21

## D

Data Collection and Processing..... 30  
Declarations of Conformity..... 231  
Direct Tire Pressure Monitoring System..... 156  
Discharging Equipment..... 90  
Disclosure of Personal Data to Authorities..... 33  
Door Bins..... 180  
Doors and Windows..... 198  
Driver Monitoring Systems..... 153  
Driving..... 121  
Driving Precautions..... 132  
Driving Safety Precautions..... 109  
Driving Safety System..... 163  
Driving with Low Fuel Consumption ..... 125

## E

Electric Fan..... 204  
Electronic Parking Brake (EPB).... 128  
Emergency Lane Keeping Assist (ELKA)\* ..... 149  
Emergency Locking Retractor (ELR) Function..... 12  
Emergency Unlocking of the Charge Port..... 97  
Emergency Vehicle Locking with Mechanical Key..... 58  
External Discharging..... 91

## F

Fire Prevention..... 117  
Folding Rear Seats..... 63  
Front 12V Power Outlet..... 183  
Front far side airbag..... 17  
Front Interior Lights Switches..... 77

Front Seat Cup Holder.....	181
Front Windshield Wipers and Washer .....	68
Front-Row USB Ports.....	182
Fuel Selection.....	111

## G

Gear Shift Controls.....	126
General Charging Troubleshooting	82
Glasses Case.....	181
Glove Box.....	180

## H

Hazard Warning Light Switch.....	77
Head-up Display.....	152
Heating and Ventilation Systems*	62
High-Voltage Battery.....	98

## I

If a Tire Goes Flat.....	216
If the Engine Fails to Start While Driving.....	213
Indicator and Warning Light.....	37
Installing Child Restraint Systems.	23
Intelligent Cruise Control (ICC)* ...	138
Intelligent High Beam Control (IHBC)*.....	146
Interior Cleaning.....	197
Introduction of Dual-Mode System Working Mode.....	25

## K

Keys.....	50
-----------	----

## L

Lane Departure Assist (LDA)* .....	147
LCD Instrument Cluster.....	36

Leather.....	198
Light Switches.....	72
Lights.....	201
Loading the Pickup Bed.....	114
Locking/Unlocking the Tailgate....	56
Locking/Unlocking with Mechanical Key.....	53
Locking/Unlocking with Smart Key .....	54
Low-Voltage Battery.....	100

## M

Maintenance Plan.....	188
Maintenance Schedule.....	188
Manual Vehicle Washing.....	196

## O

Odometer Switch.....	77
Opening and Closing the Hood....	202
Other Instrument Cluster Fault Prompts.....	46

## P

Paint Maintenance Tips.....	196
Panoramic View System* .....	158
Parking Assist System* .....	160
Power Window Switches.....	75

## R

Rear-Row USB Ports.....	182
Recycling the High-Voltage Battery .....	99
Refueling.....	111
Regular Maintenance Precautions....	194
Risk of Carbon Monoxide (CO) Poisoning.....	115

## S

Safety Handles.....	182
Saving Fuel and Extending Vehicle Service Life.....	112
Seat Belt Maintenance.....	198
Seat Belt Overview.....	12
Seat Precautions.....	61
Seat Side Airbags.....	18
Seatback Pockets.....	180
Self-Maintenance Precautions.....	199
Side Curtain Airbags.....	18
Smart Access and Start System.....	59
Smart Charging.....	89
Snow Chains.....	119
Starting the Vehicle.....	120
Steering Assist Mode Settings.....	67
Steering Wheel Switches.....	65
Suggestions for Vehicle Use and Storage.....	110
Sun Visor.....	181
Switching on A/C with Cloud Service App.....	178

## T

Target SOC Setting.....	94
Traffic Sign Recognition (TSR)* ....	140
Transponder Mounting.....	230

## U

Using AC Charging Piles.....	87
Using DC Charging Piles*.....	88
Using Mode 2 Charging Cable.....	83
Using Seat Belts.....	12
Using the Spare Tire.....	217

## V

Vehicle Cleaning.....	196
Vehicle Corrosion Prevention.....	195
Vehicle Identification Number (VIN) .....	228

Vehicle Servicing.....	194
Vehicle Specifications.....	224
Vehicle Storage Instructions.....	201

## W

Wading into Water.....	116
Warning Labels.....	229
Warning Light/Indicator Description .....	40
Washer.....	205
Window Control Switch on Passenger Side.....	76
Winter Driving Precautions.....	133
Wireless Phone Charging.....	183
Working Mode Precautions of Dual-Mode System.....	28
Working Mode Selection of Dual-Mode System.....	26



# Abbreviations

<b>Terminology</b>	<b>Full Name</b>	<b>Terminology</b>	<b>Full Name</b>
ECU	Electronic Control Unit	ISOFIX	International Standards Organization Fix
ECO	Ecology, Conservation, Optimization	SPORT	Sport
EDR	Event Data Recorder	SOC	State of Charge
EPB	Electronic Parking Brake	ACC	Adaptive Cruise Control
ICC	Intelligent Cruise Control	TSR	Traffic Sign Recognition
FCW	Forward Collision Warning	AEB	Automatic Emergency Braking
IHBC	Intelligent High Beam Control	LDW	Lane Departure Warning
LDP	Lane Departure Prevention	ELKA	Emergent Lane Keeping Assist
BSD	Blind Spot Detection	RCTA	Rear Collision Traffic Alert
RCTA	Rear Collision Traffic Alert	RCW	Rear Collision Warning
DOW	Door Open Warning	AVAS	Acoustic Vehicle Alert System
ABS	Antilock Braking System	VDC	Vehicle Dynamics Control
TCS	Traction Control System	HHC	Hill Hold Control
HBA	Hydraulic Brake Assist	CDP	Controller Deceleration Parking
HDC	Hill Descent Control	MCB	Multi-Collision Brake
MAX	Maximum	MIN	Minimum
VIN	Vehicle Identification Number		

